



TOSHIBA TEC Bar Code Printer

B-452-QQ/QP

External Equipment Interface Specification

First Edition:	November 6, 1998
Second Edition:	January 6, 1999
Third Edition:	July 16, 1999
Fourth Edition:	October 26, 1999
Fifth Edition:	March 22, 2000
Sixth Edition:	February 16, 2001

TOSHIBA TEC CORPORATION

TABLE OF CONTENTS

	Page
1. SCOPE	1
2. GENERAL DESCRIPTION	1
3. INTERFACE	2
3.1 SERIAL INTERFACE	2
3.2 PARALLEL INTERFACE	7
3.2.1 Forward Interface	7
3.2.2 Reverse Interface	12
4. KEY OPERATION FUNCTIONS	20
4.1 DIP SW FUNCTIONS	20
4.2 SELF-TEST MODE FUNCTIONS	21
4.3 MAINTENANCE MODE FUNCTIONS	21
4.4 ONLINE MODE FUNCTIONS	21
5. TRANSMISSION SEQUENCE	22
5.1 INITIALIZATION	22
5.2 LABEL ISSUE OPERATION	24
6. INTERFACE COMMANDS	26
6.1 OUTLINE OF COMMANDS	26
6.2 LIST OF COMMANDS	27
6.3 LABEL SIZE SET COMMAND	28
6.4 POSITION FINE ADJUST COMMAND	32
6.5 PRINT DENSITY FINE ADJUST COMMAND	37
6.6 RIBBON MOTOR DRIVE VOLTAGE FINE ADJUST COMMAND	38
6.7 IMAGE BUFFER CLEAR COMMAND	39
6.8 CLEAR AREA COMMAND	40
6.9 LINE FORMAT COMMAND	42
6.10 BIT MAP FONT FORMAT COMMAND	48
6.11 OUTLINE FONT FORMAT COMMAND	61
6.12 BAR CODE FORMAT COMMAND	76
6.13 BIT MAP FONT DATA COMMAND	106
6.14 OUTLINE FONT DATA COMMAND	109
6.15 BAR CODE DATA COMMAND	112
6.16 ISSUE COMMAND	120
6.17 FEED COMMAND	129
6.18 EJECT COMMAND	133
6.19 FORWARD/REVERSE FEED COMMAND	135
6.20 FORMAT COMMAND	137

	Page
6.21 2-BYTE WRITABLE CHARACTER CODE RANGE COMMAND	138
6.22 BIT MAP WRITABLE CHARACTER COMMAND	139
6.23 GRAPHIC COMMAND.....	148
6.24 SAVE START COMMAND	156
6.25 SAVE TERMINATE COMMAND	157
6.26 SAVED DATA CALL COMMAND	158
6.27 RESET COMMAND.....	159
6.28 STATUS REQUEST COMMAND	160
6.29 PARAMETER SET COMMAND	161
6.30 TRANSFER COMMAND (LAN → KB-80)	163
6.31 TRANSFER COMMAND (KB-80 → LAN)	164
6.32 STORAGE AREA ALLOCATE COMMAND.....	165
7. CONTROL CODE SELECTION.....	167
8. ERROR PROCESSING.....	168
8.1 COMMUNICATION ERRORS	168
8.2 ERRORS IN ISSUING OR FEEDING.....	168
8.3 ERRORS IN WRITABLE CHARACTER AND PC COMMAND ENTRY MODES.....	170
8.4 SYSTEM ERRORS.....	170
8.5 RESET PROCESSING.....	170
9. STATUS RESPONSE	171
9.1 SERIAL INTERFACE.....	171
9.1.1 Functions	171
9.1.2 Status Format	171
9.1.3 Detail Status	172
9.2 PARALLEL INTERFACE	173
10. KEY OPERATION	174
10.1 OPERATION PANEL.....	174
10.2 ONLINE MODE.....	174
10.2.1 Key Function.....	174
10.2.2 LED Function.....	174
10.2.3 Online Mode Operation Example.....	175
10.2.4 Reset	176
10.3 LED INDICATIONS.....	177
10.4 SELF-TEST/TEST PRINTING.....	178
10.4.1 Self-test/Test Printing Operation Example	178
10.4.2 Self-test Items.....	179
10.4.3 Self-test Results Printout Samples	181
10.4.4 Self-test Printout Contents.....	182
10.4.5 Test Print Samples	188

	Page
10.5 SENSOR ADJUSTMENT	189
10.5.1 Sensor Adjustment Operation Example	189
10.6 THRESHOLD SETTING (PREPRINTED LABEL)	190
10.6.1 Outline of Threshold Setting	190
10.6.2 Threshold Setting Operation Example.....	190
10.7 RAM CLEAR OPERATION EXAMPLE.....	192
10.7.1 RAM Clear Operation Example	192
10.7.2 RAM Clear Contents.....	193
11. CHARACTER CODE TABLE	195
11.1 TIMES ROMAN, HELVETICA, LETTER GOTHIC, PRESTIGE ELITE, COURIER	195
11.2 PRESENTATION.....	202
11.3 OCR-A	203
11.4 OCR-B	204
11.5 TEC OUTLINE FONT 1	205
11.6 PRICE FONT	212
11.7 TEC OUTLINE FONT 2, 3	213
11.8 TrueType FONT.....	220
12. BAR CODE TABLE.....	227
13. DRAWING OF BAR CODE DATA.....	239
14. AUTOMATIC ADDING OF START/STOP CODE.....	260

1. SCOPE

This specification applies to the external equipment interface for use with the Model B-452-QQ/QP general purpose thermal label/tag printers.

2. GENERAL DESCRIPTION

The external equipment interface, a serial interface (RS-232C) or parallel interface (Centronics), is available for operating this printer. The three LEDs indicate the printer states. Two keys on the printer can be used when the printer is offline. This specification describes how to use the external equipment interface, key operations, and provides LED definitions.

The differences between the B-452-QQ and the B-452-QP are described below.

	B-452-QQ	B-452-QP
Writable character areas	10 types Capacity: 48 Kbytes	45 types Capacity: 960 Kbytes
Interface	RS-232C	RS-232C, Centronics

3. INTERFACE

3.1 SERIAL INTERFACE

- (1) Type: Conforming to RS-232C
- (2) Mode of Communication: Full duplex
- (3) Transmission Speed: 2400 bps
4800 bps
9600 bps
19200 bps
- (4) Synchronization Method: Start-stop synchronization
- (5) Start Bit: 1 bit
- (6) Stop Bit: 1 bit
- (7) Data Length: 8 bitsp
- (8) Parity: None
Even
- (9) Error Detection:
 - Parity Error Vertical parity error check
 - Framing Error This error occurs if no stop bit is found in the frame specified starting with the start bit.
 - Overrun Error This error occurs if the next data is input before the data input to the UART from the host is read.
- (10) Protocol: No-procedure method
- (11) Data Input Code: ASCII code
European character set 8 bit code
Graphics 8 bit code
- (12) Receive Buffer: 5K bytes

- (13) Transmission Control: XON/XOFF (DC1/DC3) Protocol
READY/BUSY (DTR) Protocol
XON/XOFF (DC1/DC3) Protocol + READY/BUSY (DTR) Protocol
READY/BUSY (RTS) Protocol

① XON/XOFF (DC1/DC3) Protocol

- When initialized after power on, this printer becomes ready to receive data and sends an XON code (11H). (Transmission or non-transmission of the XON code is selectable by means of the parameter setting.)
- The printer sends an XOFF code (13H) when the blank positions in the receive buffer become 800 bytes or less.
- The printer sends an XON code (11H) when the blank positions in the receive buffer are 2K bytes or more.
- When there are no blank positions in the receive buffer, the printer discards data received exceeding the receive buffer capacity, without storing it in the buffer. (After detecting the XOFF code, the host computer must stop transmission before the printer receive buffer becomes full.)
- The printer sends an XOFF code (13H) when the power is off. (Transmission or non-transmission of the XOFF code is selectable by means of the parameter setting.)

② READY/BUSY (DTR) Protocol

- When initialized after power on, this printer becomes ready to receive data and turns the DTR signal to "High" level (READY).
- The printer turns the DTR signal to "Low" level (BUSY) when the blank positions in the receive buffer are 800 bytes or less.
- The printer turns the DTR signal to "High" level (READY) when the blank positions in the receive buffer are 2K bytes or more.
- When there are no blank positions in the receive buffer, the printer discards data received exceeding the receive buffer capacity, without storing it in the buffer. (After detecting the BUSY signal, the host computer must stop transmission before the printer receive buffer becomes full.)

③ XON/XOFF (DC1/DC3) Protocol + READY/BUSY (DTR) Protocol

- When initialized after power on, this printer becomes ready to receive data and turns the DTR signal to "High" level (READY). It also sends an XON code (11H).
- When the blank positions in the receive buffer are 800 bytes or less, the printer turns the DTR signal to "Low" level (BUSY) and sends an XOFF code (13H).
- When the blank positions in the receive buffer are 2K bytes or more, the printer turns the DTR signal to "High" level (READY) and sends an XON code (11H).
- When there are no blank positions in the receive buffer, the printer discards data received exceeding the receive buffer capacity, without storing it in the buffer. (After detecting the XOFF code or BUSY signal, the host computer must stop transmission before the printer receive buffer becomes full.)
- The printer sends an XOFF code (13H) when the power is off.

④ READY/BUSY (RTS) Protocol

- When initialized after the power is turned on, this printer becomes ready to receive data and turns the RTS signal to “High” (READY).
- The printer turns the RTS signal to “Low” (BUSY) when the blank positions in the receive buffer are 800 bytes or less.
- The printer turns the RTS signal to “High” (READY) when the blank positions in the receive buffer are 2K bytes or more.
- When there are no blank positions in the receive buffer, the printer discards data received exceeding the receive buffer capacity, without storing it in the buffer. (After detecting the BUSY signal, the host computer must stop transmission before the printer receive buffer becomes full.)
- The printer must always turn the DTR signal to “High”. The host must always turn the DSR signal to “High”.

Notes for storing the writable character/PC save commands

1. The printer outputs a BUSY signal when the flash memory is initialized or storage is performed in the flash memory. When the initialization of the flash memory or the storage in the flash memory is completed, the printer outputs a READY signal. (The host stops data transmission upon detecting the BUSY signal, or resumes data transmission upon detecting the READY signal.) READY/BUSY output is selectable by means of the parameter setting (transmission control protocol.)
2. In the case that the READY/BUSY control is not performed
 - (1) When the format command and store command (Writable character/PC save commands) are sent consecutively, the next command should be sent 5 seconds after the store command (Writable character/PC save commands) is sent.
 - (2) When only the format command is sent, the next command should be sent 5 seconds after the format command is sent.
 - (3) When only the store command, such as a writable character/PC save command, is sent, the next command should be sent 5 seconds after the store command.

(14) Input/Output Signals

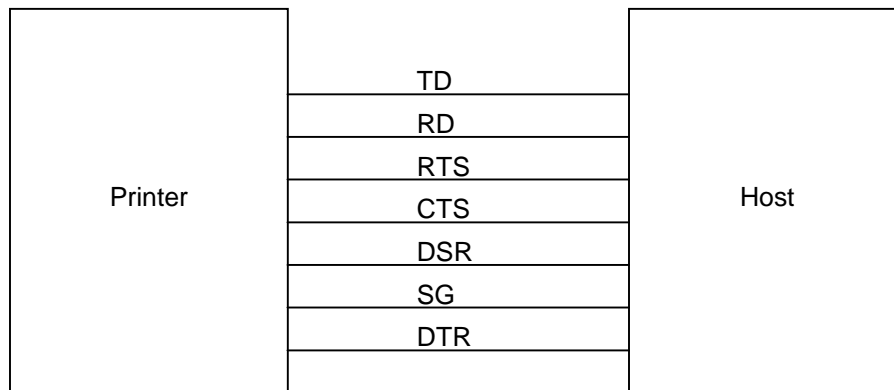

(15) Connector Pin Assignment and Signal Description

Pin No.	Signal Name	Function	Signal Direction
1	(N.C)		
2	TD	<ul style="list-style-type: none"> ● Line for data which the printer sends to the host. ● Logic 1 is Low level, while logic 0 is High level. ● It is in the Low (Mark) state when no transmission is in progress. 	Printer →
3	RD	<ul style="list-style-type: none"> ● Line for data which the printer receives from the host. ● Logic 1 is Low level, while logic 0 is High level. ● It is in the Low (Mark) state when no transmission is in progress. 	← Host
4	DSR	<ul style="list-style-type: none"> ● Input signal from the host. ● For the printer to receive data, it must be "High". 	← Host
5	SG	<ul style="list-style-type: none"> ● Ground line for all data and control signals. 	
6	DTR	<ul style="list-style-type: none"> ● Output signal to the host. <p>For the READY/BUSY (DTR) protocol:</p> <ul style="list-style-type: none"> ● It indicates the ready state for the received data. ● It is at "Low" level when the receive buffer is nearly full, and at "High" level when nearly empty. <p>For the READY/BUSY (RTS) protocol:</p> <ul style="list-style-type: none"> ● After the power is turned on, it is always "High". 	Printer →
7	CTS	<ul style="list-style-type: none"> ● Input signal from the host. ● For the printer to send data, the signal must be "High". 	← Host
8	RTS	<ul style="list-style-type: none"> ● Output signal to the host. <p>For the READY/BUSY (DTR) protocol:</p> <ul style="list-style-type: none"> ● It indicates that there is data to be output to the host. ● After the power is turned on, it is always "High". <p>For the READY/BUSY (RTS) protocol:</p> <ul style="list-style-type: none"> ● It indicates the ready state for the received data. ● It is at "Low" level when the receive buffer is nearly full, and at "High" level when nearly empty. 	Printer →
9	(N.C)		

(16) Interface Circuit

● Input Circuit

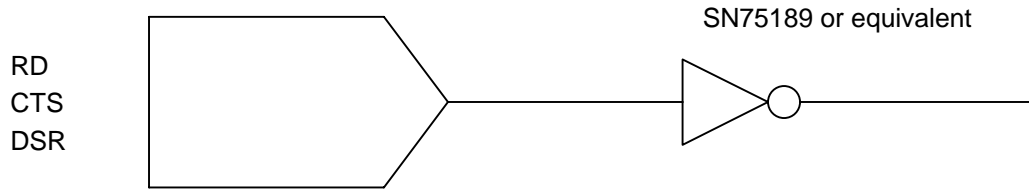

● Output Circuit

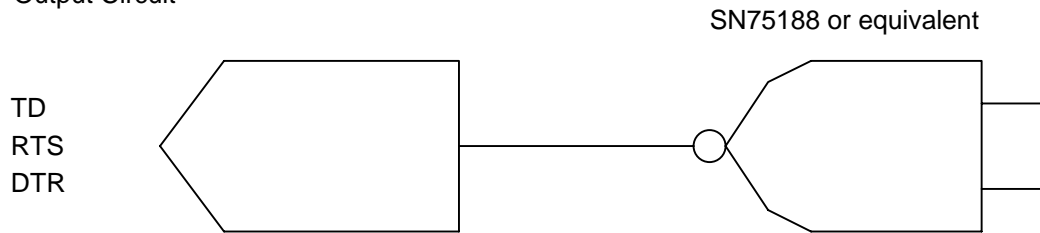

● Signal Levels

Input Voltage	H	+3 ~ +15V
	L	-3 ~ -15V
Output Voltage	H	+6 ~ +13V
	L	-6 ~ -13V

3.2 PARALLEL INTERFACE

3.2.1 Forward Interface

- (1) Type: Centronics
- (2) Data Input Method: Parallel 8 bits (DATA 1 ~ 8)
- (3) Control Signals: $\overline{\text{ACK}}$, $\overline{\text{BUSY}}$, $\overline{\text{PAUSE}}$, $\overline{\text{DATA} \bullet \text{STB}}$, $\overline{\text{FAULT}}$, PE, $\overline{\text{INPUT} \bullet \text{PRIME}}$
- (4) Data Input Code: ASCII code
European character set 8 bit code
Graphics 8 bit code
- (5) Receive Buffer: 5K bytes
- (6) Input/Output Circuit Configuration and Input/Output Conditions:

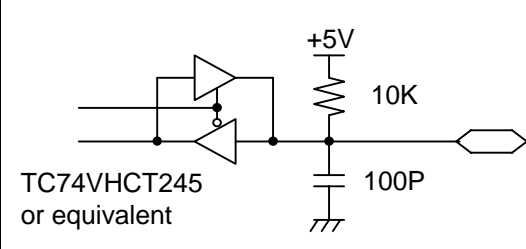
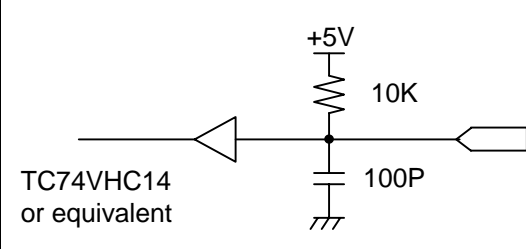
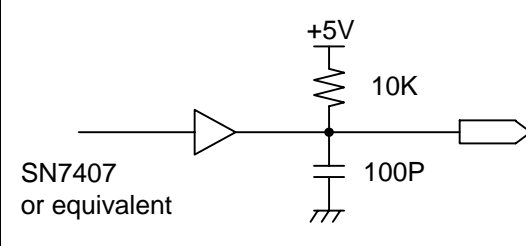
	Signal	Configuration	
Input	DATA 1 ~ 8	 <p>TC74VHCT245 or equivalent</p>	Logical level (Input) "1" = 2 ~ 5 V "0" = 0 ~ 0.4 V
	$\overline{\text{DATA} \bullet \text{STB}}$ $\overline{\text{INPUT} \bullet \text{PRIME}}$	 <p>TC74VHC14 or equivalent</p>	
Output	$\overline{\text{BUSY}}$, $\overline{\text{FAULT}}$, $\overline{\text{ACK}}$, $\overline{\text{PAUSE}}$, PE	 <p>SN7407 or equivalent</p>	Logical level (Input) "1" = 2.4 ~ 5 V "0" = 0 ~ 0.4 V

- (7) Connector:
 - Printer
 - Amp. Japan 552742-1 or equivalent
 - DDK 57RE-40360-73B or equivalent
 - Cable
 - Amp. Japan 552470-1 or equivalent
 - DDK 57E-30360 or equivalent

(8) Connector Pin Diagram:

Pin No.	Signal Name	Pin No.	Signal Name
1	DATA • STB	19	TWISTED PAIR GND (PIN1)
2	DATA 1	20	TWISTED PAIR GND (PIN2)
3	DATA 2	21	TWISTED PAIR GND (PIN3)
4	DATA 3	22	TWISTED PAIR GND (PIN4)
5	DATA 4	23	TWISTED PAIR GND (PIN5)
6	DATA 5	24	TWISTED PAIR GND (PIN6)
7	DATA 6	25	TWISTED PAIR GND (PIN7)
8	DATA 7	26	TWISTED PAIR GND (PIN8)
9	DATA 8	27	TWISTED PAIR GND (PIN9)
10	ACK	28	TWISTED PAIR GND (PIN10)
11	BUSY	29	TWISTED PAIR GND (PIN11)
12	PE	30	TWISTED PAIR GND (PIN31)
13	PAUSE	31	INPUT • PRIME
14	0V	32	FAULT
15	NC	33	0V
16	0V	34	NC
17	CHASSIS GND	35	NC
18	+5V	36	NC

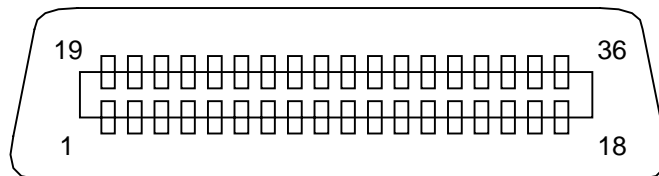

(9) Input/Output Signals:

- ① DATA 1 ~ 8 (Printer ← Host)
 - Input data signals for the 1st to 8th bits.
 - Logic 1 is “High” level.
 - Min. data pulse width of 2.5 μ sec.
- ② $\overline{\text{DATA}} \bullet \overline{\text{STROBE}}$ ($\overline{\text{DATA}} \bullet \overline{\text{STB}}$) (Printer ← Host)
 - Synchronizing signal for reading the above data.
 - Normally at “High” level. The data is read at the rise of the Low level pulse.
 - Minimum data pulse width of 0.5 μ sec.
- ③ BUSY (Printer → Host)
 - This signal indicates that the printer is in a BUSY state.
 - When initialized after power on, the printer becomes ready to receive data and turns the signal to “Low” level.
 - The signal turns to “High” level (in a BUSY state) when data is set from the host (at the fall of the $\overline{\text{DATA}} \bullet \overline{\text{STB}}$ signal).
 - The signal turns to “Low” level when the printer reads the data.
 - When the blank positions in the receive buffer are 512 bytes or less, the printer keep the signal at “High” level (in a BUSY state) for 10 seconds when data is set from the host, to extend the data read interval.
 - When there are no blank positions in the receive buffer, the printer stops reading data. Then, it keeps the signal at “High” level (in a BUSY state) until there are blank positions in the receive buffer when data is set from the host.
 - The signal is kept at “High” level (in a BUSY state) until the current state (one of the following states) is reset.
 - PAUSE state caused by the [PAUSE] key
 - Paper End state
 - Ribbon Error state
 - Head Open state
 - Printer Error state
 - Initialization in progress upon receipt of the $\overline{\text{INPUT}} \bullet \overline{\text{PRIME}}$ signal
- ④ $\overline{\text{ACKNOWLEDGE}}$ ($\overline{\text{ACK}}$) (Printer → Host)
 - This signal indicates that the printer has read the data set by the host and is ready to receive the next data.
 - Normally at “High” level. It is at “Low” level for about 5 μ sec. after the fall of the BUSY signal.
 - The host should usually set data after the $\overline{\text{ACK}}$ signal turns from “Low” to “High” level.
 - If the host ignores the $\overline{\text{ACK}}$ signal and sets the next data while the $\overline{\text{ACK}}$ signal is at “Low” level, the signal will further continue to be at “Low” level for about 5 μ sec. after the fall of the BUSY signal (the data will still be received normally in this case).

- ⑤ $\overline{\text{INPUT}} \bullet \overline{\text{PRIME}}$ (Printer \leftarrow Host)
 - Reset request signal from the host.
 - Normally at “High” level. A low on this input causes the printer to be initialized in the same manner as when the power is turned on.
 - When the $\overline{\text{INPUT}} \bullet \overline{\text{PRIME}}$ signal is input during printing, the printer finish printing one tag label in printing and then cancels the next processing and is initialized in the same manner as when the power is turned on.
 - Minimum pulse width of 0.5 μsec .
- ⑥ $\overline{\text{PAUSE}}$ (Printer \rightarrow Host)
 - This is an output signal which indicates whether the printer is in PAUSE state or placed online. The printer can receive data while placed online.
 - The signal is at “Low” level while the printer is in a PAUSE state.
 - The signal is kept at “Low” level (in a PAUSE state) until the current state (one of the following states) is reset.
 - PAUSE state caused by the [PAUSE] key
 - Paper End state
 - Ribbon Error state
 - Head Open state
 - Printer Error state
 - Initialization in progress upon power on or receipt of the $\overline{\text{INPUT}} \bullet \overline{\text{PRIME}}$ signal
- ⑦ $\overline{\text{FAULT}}$ (Printer \rightarrow Host)
 - Output signal indicating that the printer is in a FAULT state.
 - At “Low” level while the printer is in a FAULT state.
 - The signal is kept at “Low” level (in a FAULT state) until the current state (one of the following states) is reset.
 - PAUSE state caused by the [PAUSE] key
 - Paper End state
 - Ribbon Error state
 - Head Open state
 - Printer Error state
 - Initialization in progress upon power on or receipt of the $\overline{\text{INPUT}} \bullet \overline{\text{PRIME}}$ signal
- ⑧ PE (Printer \rightarrow Host)
 - Output signal indicating a Label End state.
 - At “High” level when a Label End state occurs.
 - Turns to “Low” level when the Label End state is reset.
- ⑨ +5 V
 - This is not a signal but a +5 V power supply voltage.
 - The maximum current of 500 mA can be taken out.

(10) Timing Chart

① When receiving normal data:

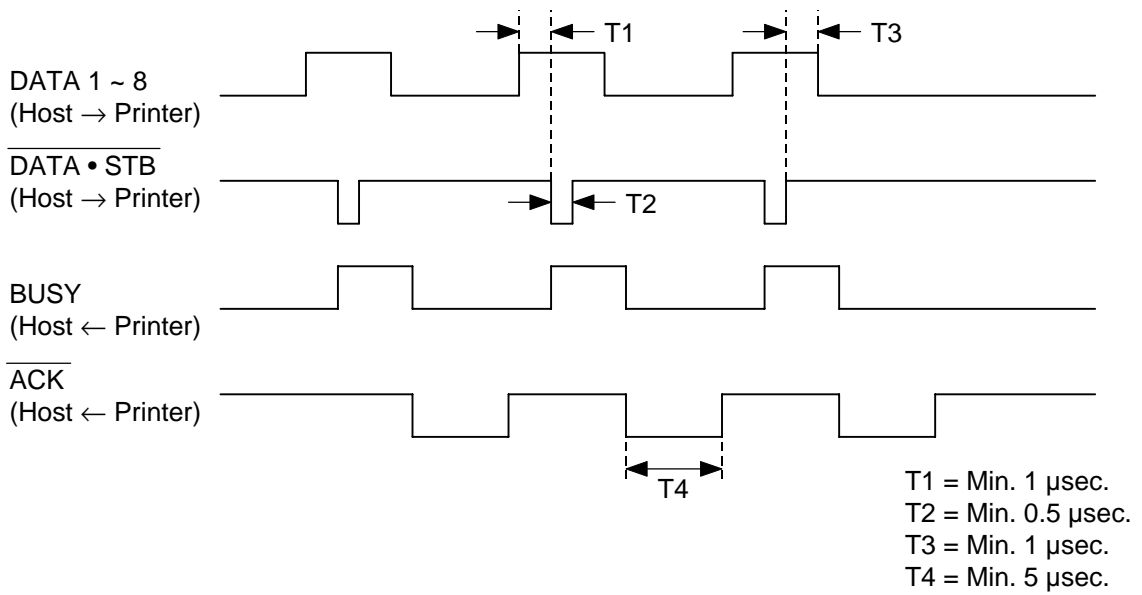

② Receiving data when the blank positions in the receive buffer are 512 bytes or less:

- When the blank positions in the receive buffer are 512 bytes or less, the printer continues to be in a BUSY state (BUSY signal at “High” level) for 10 seconds to extend the data read interval when data is set from the host and reads the data 10 seconds later.
- If the blank positions are 513 bytes or more while waiting for reading data, the printer will receive the data with the normal data receive timing.
- When there are no blank positions in the receive buffer, the printer stops reading data. Then, it continues to be in a BUSY state (BUSY signal at “High” level) until there are blank positions in the receive buffer when data is set from the host.

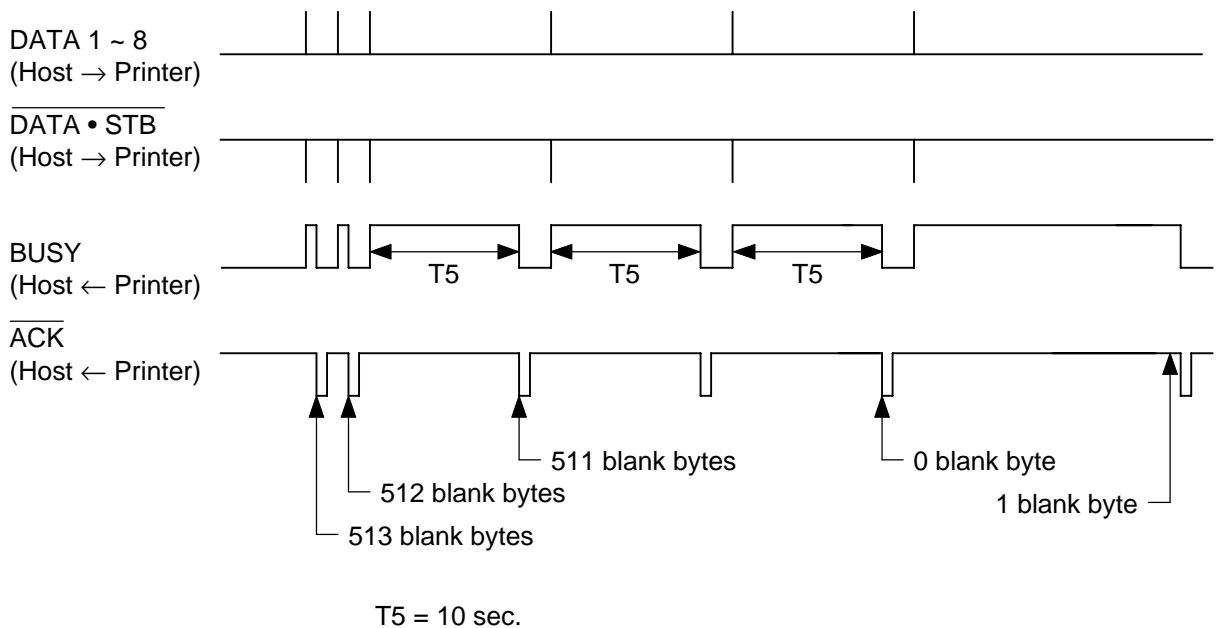

3.2.2 Reverse Interface

- (1) Type: IEEE1284
- (2) Data Output Method: Nibble mode (DataAvail, Xflag, AckDataReq, PtrBusy)
- (3) Control Signals: HosClk, PtrClk, PtrBusy, AckDataReq, Xflag, HostBusy, $\overline{\text{Init}}$, $\overline{\text{DataAvail}}$, IEEE1284Active
- (4) Data Output Code: ASCII code (8 bits)
- (5) Receive Buffer: 13 bytes
- (6) Input/Output Circuit Configuration and Input/Output Conditions:

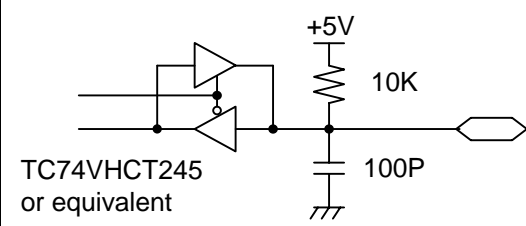
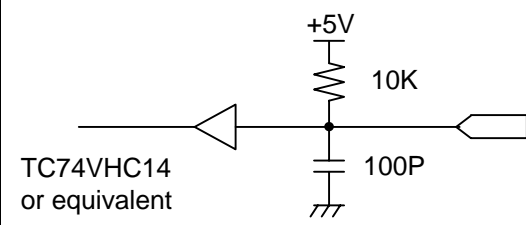
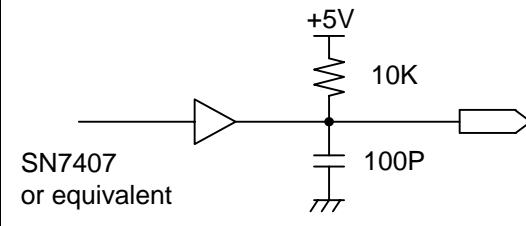
	Signal	Configuration	
Input	DATA1 ~ 8	 <p>TC74VHCT245 or equivalent</p>	Logical level (Input) "1" = 2 ~ 5 V "0" = 0 ~ 0.4 V
	HostClk, HostBusy, $\overline{\text{Init}}$, IEEE1284Active	 <p>TC74VHC14 or equivalent</p>	
Output	PtrClk, PrtBusy, AckDataReq, Xflag, $\overline{\text{DataAvail}}$	 <p>SN7407 or equivalent</p>	Logical level (Input) "1" = 2.4 ~ 5 V "0" = 0 ~ 0.4 V

- (7) Connector:
 - Printer
 - Amp. Japan 552742-1 or equivalent
 - DDK 57RE-40360-73B or equivalent
 - Cable
 - Amp. Japan 552470-1 or equivalent
 - DDK 57E-30360 or equivalent

(8) Connector Pin Diagram:

Pin No.	Signal Name	Pin No.	Signal Name
1	HostClk	19	TWISTED PAIR GND (PIN1)
2	DATA 1	20	TWISTED PAIR GND (PIN2)
3	DATA 2	21	TWISTED PAIR GND (PIN3)
4	DATA 3	22	TWISTED PAIR GND (PIN4)
5	DATA 4	23	TWISTED PAIR GND (PIN5)
6	DATA 5	24	TWISTED PAIR GND (PIN6)
7	DATA 6	25	TWISTED PAIR GND (PIN7)
8	DATA 7	26	TWISTED PAIR GND (PIN8)
9	DATA 8	27	TWISTED PAIR GND (PIN9)
10	PtrClk	28	TWISTED PAIR GND (PIN10, PIN12, PIN13)
11	PtrBusy	29	TWISTED PAIR GND (PIN11, PIN32)
12	AckDataReq	30	TWISTED PAIR GND (PIN14, PIN31, PIN36)
13	Xflag	31	$\overline{\text{Init}}$
14	HostBusy	32	$\overline{\text{DataAvail}}$
15	NC	33	0V
16	0V	34	NC
17	CHASSIS GND	35	NC
18	+5V	36	IEEE1284Active

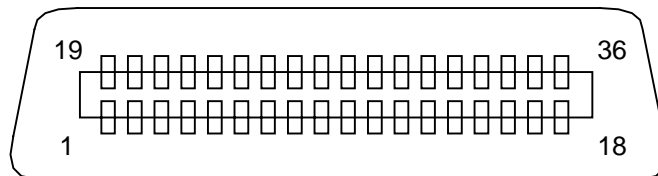

(9) Input/Output Signals:

- ① DATA 1 ~ 8 (Printer ← Host)
 - Input data signals for receiving information of the 1st to 8th bits.
 - Logic 1 is the “High” level.
 - Min. data pulse width of 2.5 μ sec.
- ② HostClk (Printer ← Host)
 - Synchronizing input signal for reading the above data.
 - Normally at “High” level. The data is read at the rise of the Low level pulse.
 - Minimum data pulse width of 0.5 μ sec.
- ③ PtrClk (Printer → Host)
 - Synchronizing output signal in order that the host reads the data that the printer sets.
 - Normally at “High” level. The data is read at the fall of the Low level pulse.
- ④ PtrBusy (Printer → Host)
 - This signal is used as the printer output data bit 3 or 7.
 - In the nibble mode, 8-bit data is transferred by transferring 4-bit data twice. Data bit 3 is used for the first transfer. Data bit 7 is used for the second transfer.
 - When the signal is high, a bit is ON (= 1). When the signal is low, a bit is OFF (= 0).
- ⑤ AckDataReq (Printer → Host)
 - This signal is used as the printer output data bit 2 or 6.
 - In the nibble mode, 8-bit data is transferred by transferring 4-bit data twice. Data bit 2 is used for the first transfer. Data bit 6 is used for the second transfer.
 - When the signal is high, a bit is ON (= 1). When the signal is low, a bit is OFF (= 0).
- ⑥ Xflag (Printer → Host)
 - This signal is used as the printer output data bit 1 or 5.
 - In the nibble mode, 8-bit data is transferred by transferring 4-bit data twice. Data bit 1 is used for the first transfer. Data bit 5 is used for the second transfer.
 - When the signal is high, a bit is ON (= 1). When the signal is low, a bit is OFF (= 0).
- ⑦ HostBusy(Printer ← Host)
 - This signal indicates that the host has read the data set by the printer and is ready to receive the next data.
 - Normally at “High” level. It becomes “Low” when the host is ready to receive the next data.
 - When receiving data is completed, the signal becomes high. When the host is ready to receive the next data, the signal becomes low.
- ⑧ $\overline{\text{Init}}$ (Printer ← Host)
 - Reset request signal from the host.
 - Normally at “High” level. When the signal becomes low, the printer mode is changed from the nibble mode to Centronics mode forcefully, then the parallel interface is initialized.
 - Minimum pulse width of 0.5 μ sec.

⑨ DataAvail (Printer → Host)

- This signal indicates the printer has the data to be sent to the host. When the signal is low, it indicates the printer has data to be sent to the host. When the signal is high, it indicates the printer does not have data to be sent to the host.

⑩ IEEE1284Active (Printer ← Host)

- The signal indicates the host is in the nibble mode, including the step that the printer state shifts to the nibble mode.
- The signal becomes high at the beginning of the shift to the nibble mode, and remains high until the nibble mode is completed.

(10) Timing Chart

The reverse data transmission consists of the following 3 steps.

- ① Negotiation phase (Shifts from the Centronics to the nibble mode.)
- ② Transfer phase (Transfers the data from the printer to the host.)
- ③ End phase (Returns to the Centronics mode from the nibble mode.)

After the negotiation phase to shift to the nibble mode, the printer must output 13 bytes of the printer status to the host in the nibble mode. (Refer to “9.1.2 Status Format”.)

① Negotiation phase

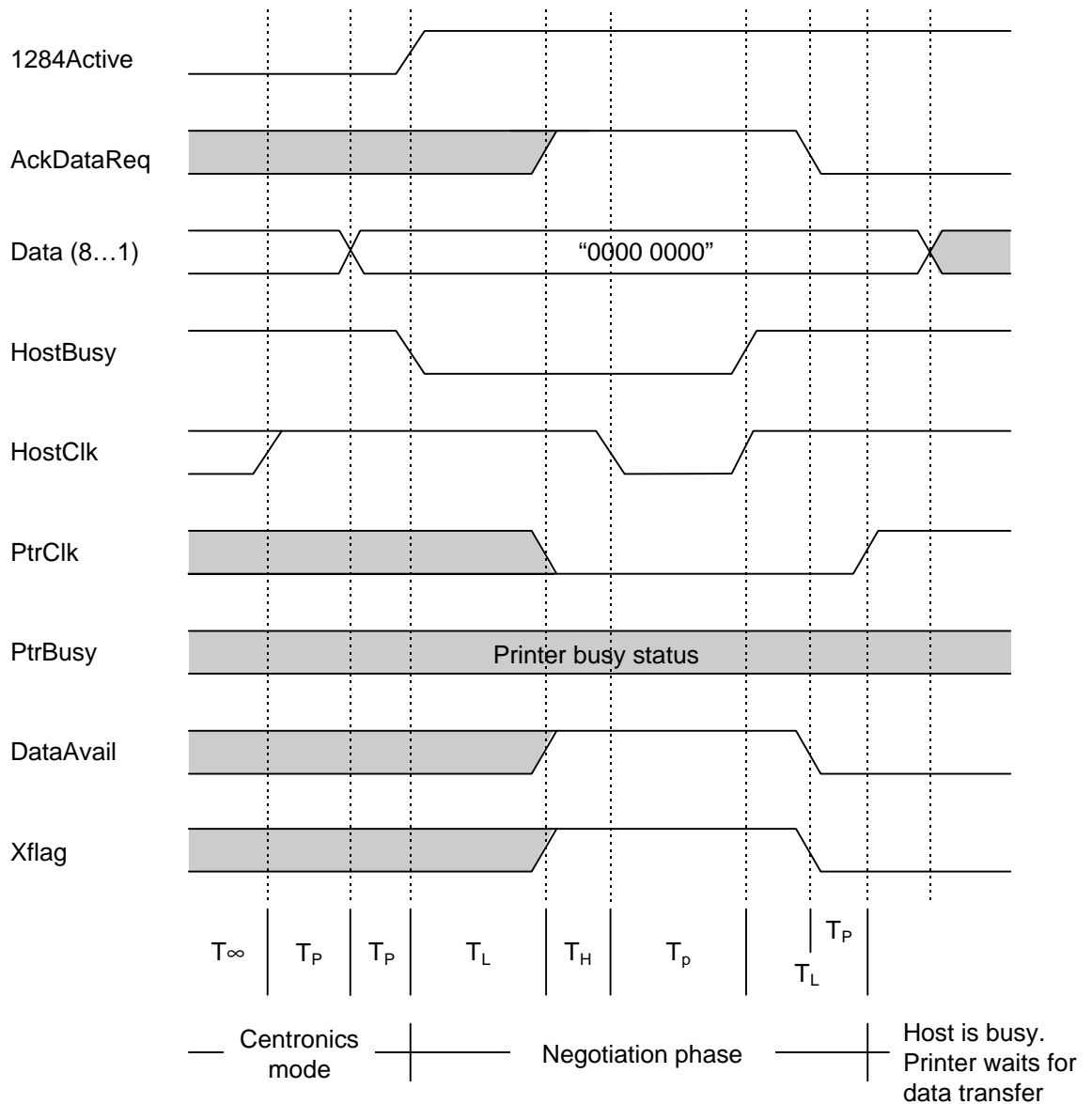

T_H : Host response time T_{∞} : Infinite response time
 T_L : Peripheral equipment response time T_P : Min. set value, Min. pulse width

Min./Max. value for each time

Time	Min. value	Max. value	Explanation
T_H	0	1.0 s	Host response time
T_{∞}	0	Infinite	Infinite response time
T_L	0	35 ms	Peripheral equipment response time
T_P	0.5 μ s		Min. set value or Min. pulse width

② Transfer phase (from 1st byte to 12th byte)

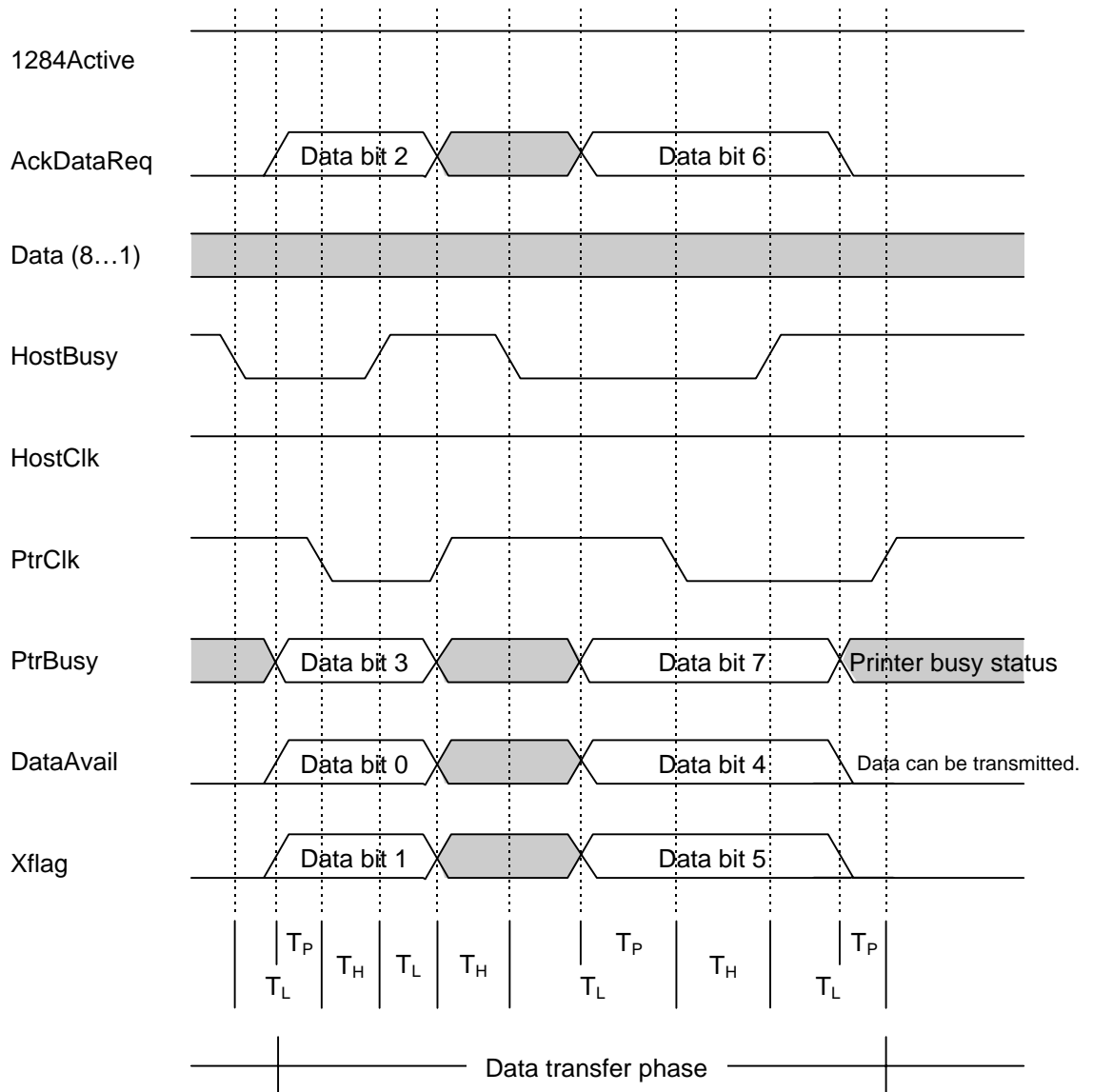

T_H : Host response time

T_∞ : Infinite response time

T_L : Peripheral equipment response time

T_P : Min. set value, Min. pulse width

③ Transfer phase (13th byte)

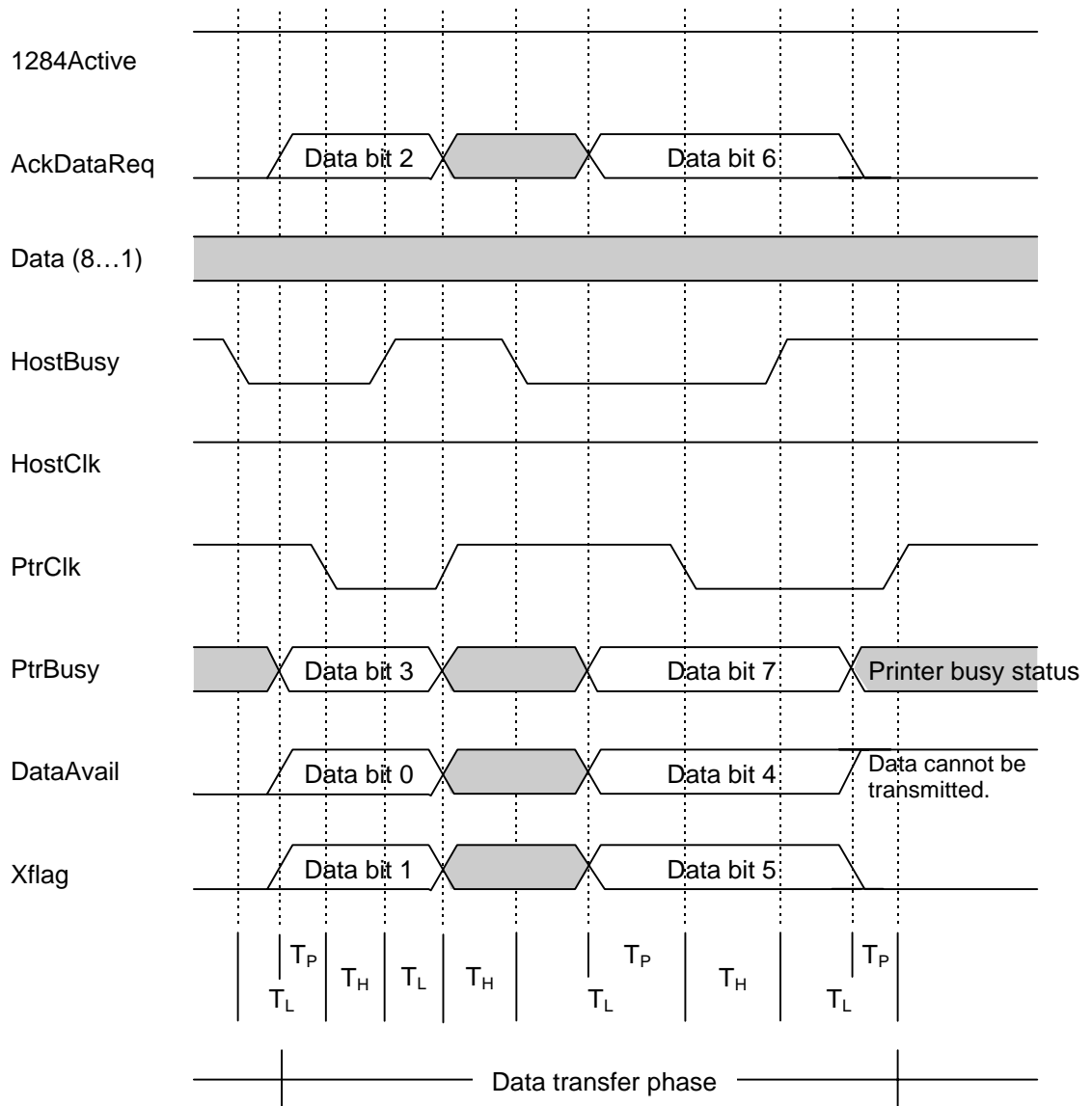

T_H : Host response time

T_∞ : Infinite response time

T_L : Peripheral equipment response time

T_P : Min. set value, Min. pulse width

- The 8-bit data is transmitted by transmitting the 4-bit data twice.

④ End phase

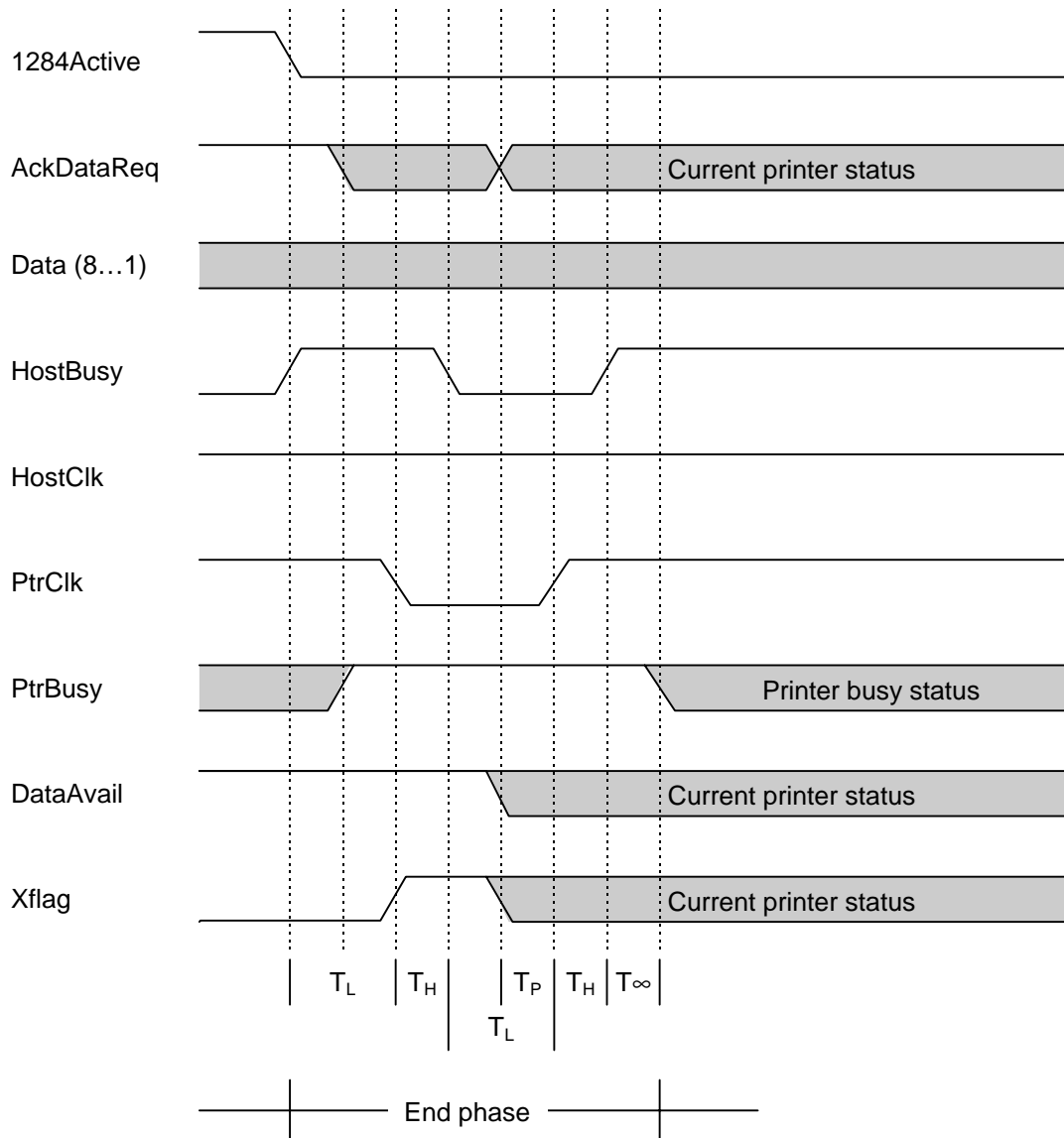

T_H : Host response time T_∞ : Infinite response time
 T_L : Peripheral equipment response time T_P : Min. set value, Min. pulse width

(11) Parallel Interface Mode for the Host

If the ECP mode is selected as the parallel interface mode for the host when an error occurs in the printer while the host is transferring the data to the printer, the host may not be able to obtain the printer error status. (It is indicated as a communication error.)

If the standard mode is selected as the parallel interface mode for the host, the error status can be obtained properly.

4. KEY OPERATION FUNCTIONS

4.1 DIP SW FUNCTIONS

No.	ON/OFF		Function	Note
	1	2		
1	OFF	OFF	2400 bps	Transmission speed
	ON	OFF	4800 bps	
2	OFF	ON	9600 bps	
	ON	ON	19200 bps	
3	OFF		NONE	None parity/Even parity
	ON		EVEN	
4	OFF		Fixed	—
	ON		—	
5	OFF		Yes	Automatic forward feed standby
	ON		No	
6	6	7		Maintenance mode selection when No. 8 is set to ON.
	OFF	OFF	RAM clear mode (Maintenance counter)	
7	ON	OFF	Threshold manual setting mode	Switching winding torque of the backing paper rewind motor when No. 8 is set to OFF. (2"/s)
	OFF	ON	Sensor adjustment mode	
	ON	ON	RAM clear mode (Parameter)	
8	OFF		Normal operation mode	Operation mode
	ON		Maintenance mode, Remote program load mode	

* The DIP switch statuses are read when the printer power is turned on.

* When DIP SW No. 8 is set to ON, and the printer power is turned on while the [FEED] key is being pressed or the [FEED] and [PAUSE] keys are being pressed at the same time, the printer enters each mode according to the setting for No. 6 or No. 7. When the printer power is turned on without pressing the key(s), the printer enters the remote program load mode.

* Turning No. 8 off switches the winding torque of the backing paper rewind motor as shown below when the motor issues 2"/s according to the selection in No. 6 and 7. No. 7 must be turned OFF.

No. 6	No. 7	Winding torque of the backing paper rewind motor (Inner D/A value)
OFF	OFF	70H (to be selected for thinner backing paper)
ON	OFF	A0H (to be selected for thicker backing paper)
OFF	ON	Unable to select
ON	ON	Unable to select

4.2 SELF-TEST MODE FUNCTIONS

(For details, refer to chapter 10.)

- (1) Self-test + Test printing
 - Automatic self-test
 - Maintenance counter/Various parameters printing
 - Slant line printing

4.3 MAINTENANCE MODE FUNCTIONS

(For details, refer to chapter 10.)

- (1) Sensor adjustment
 - Reflective sensor adjustment
 - Transmissive sensor adjustment
- (2) Manual threshold setting
 - Reflective sensor
 - Transmissive sensor
- (3) RAM clear
 - Maintenance counter clear
 - Parameter clear

4.4 ONLINE MODE FUNCTIONS

The online mode provides the following functions.

(For details, refer to chapter 10.)

- (1) Issuing labels (by external equipment interface commands)
- (2) Paper feed (by the [FEED] key)
- (3) Pause (Halts issuing labels by the [PAUSE] key)
- (4) Restart (Reissues labels by the [PAUSE] key after halting a label issue or after the occurrence of an error.)
- (5) Reset (Enters the usual initial state which is normally obtained after the power is turned on, using the [PAUSE] key.)

5. TRANSMISSION SEQUENCE

This section describes the outline of the transmission sequence.

5.1 INITIALIZATION

Writable characters, logos, and PC interface commands must be stored before the label issue operation.

(1) Storing writable characters and logos

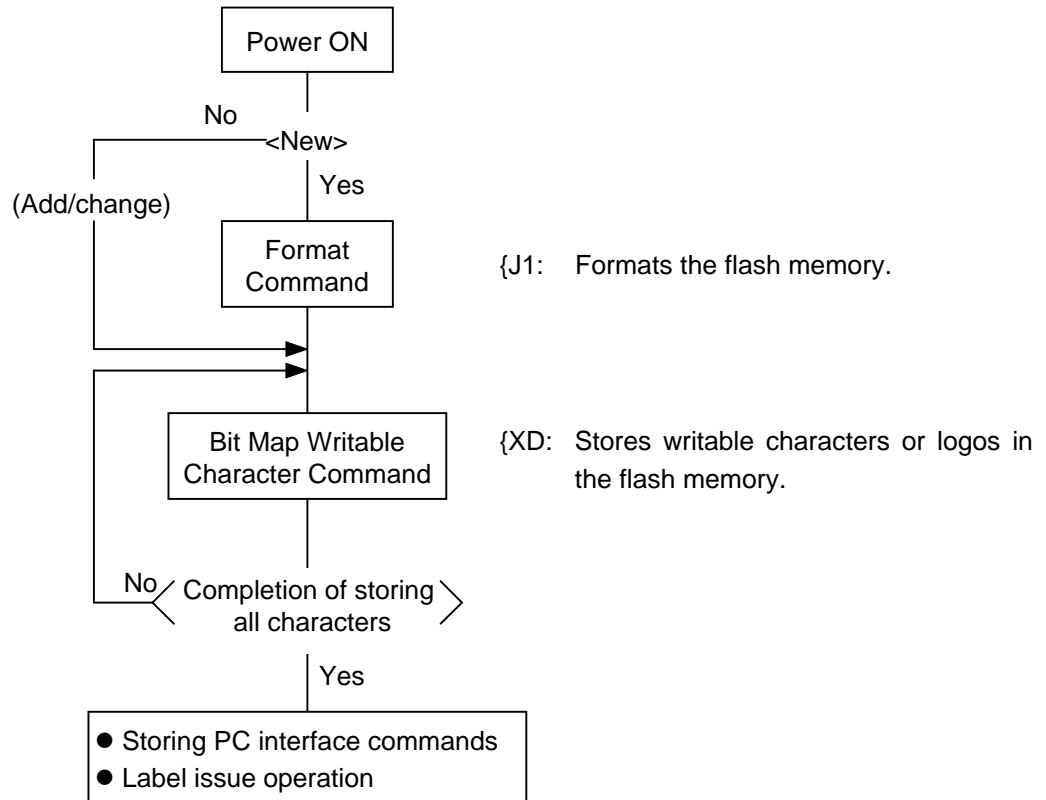

- NOTES:**
- (1) *The storage of writable characters or logos is only performed if they are being used.*
 - (2) *Unless the Format Command is sent before storing already stored writable characters or logos (storing the same numbers), memory will be consumed each time something is stored again.*
 - (3) *Before another operation (storing PC interface commands, label issue operation) is performed after storing writable characters or logos, the image buffer will be cleared automatically.*
 - (4) *If another storing operation is not continued after storing writable characters or logos, the printer automatically enters the online mode (label issue operation) after about 10 seconds. In this case, the image buffer will be cleared automatically.*

(2) Storing PC interface commands

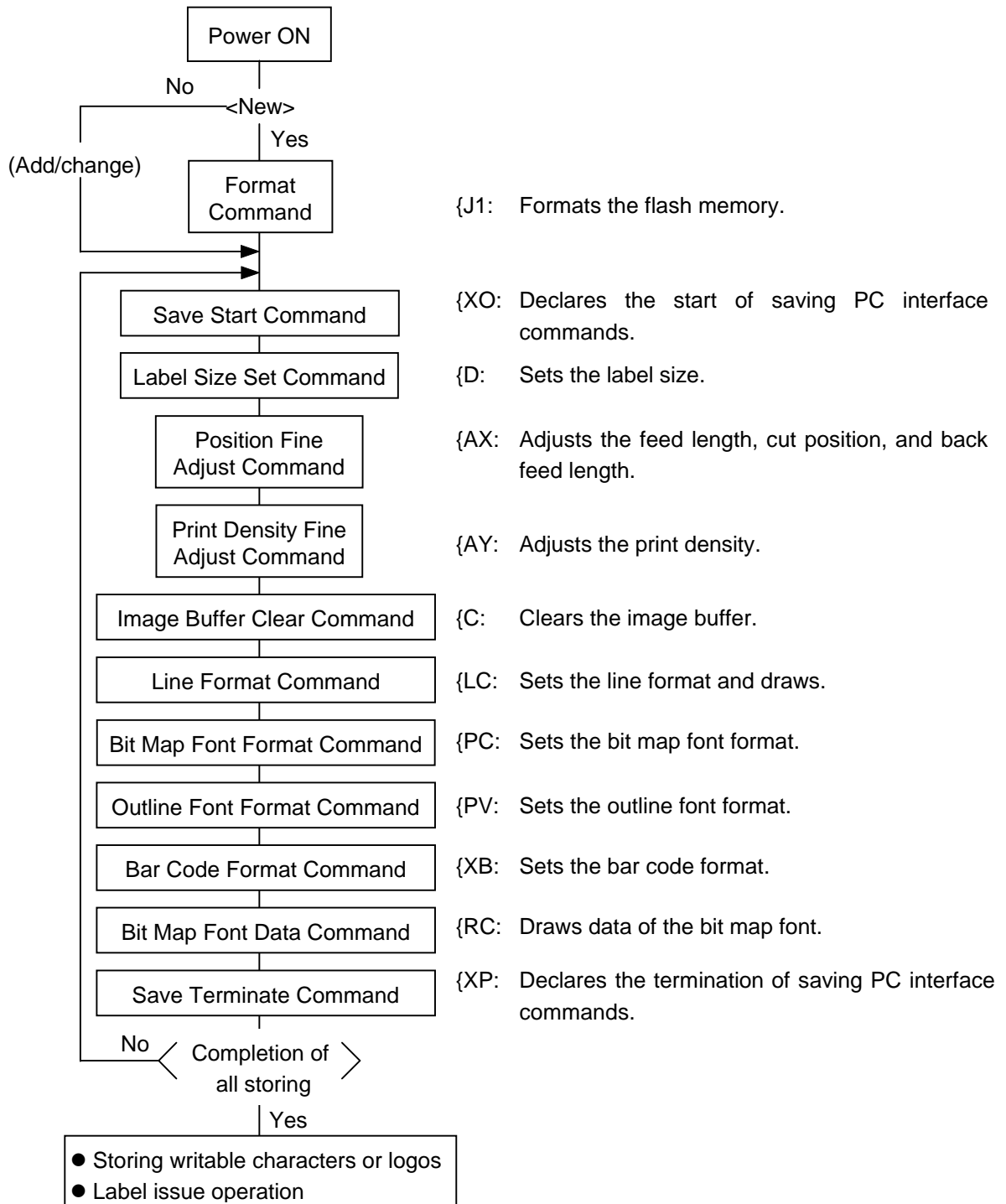

- NOTES:**
- (1) The storage of PC interface commands is only performed if they are being used.
 - (2) Unless the Format Command is sent before storing already stored PC interface commands (storing the same numbers), memory will be consumed each time something is stored again.
 - (3) Before another operation (storing writable characters, logos, or label issue operation) is performed after storing PC interface commands, the image buffer will be cleared automatically.
 - (4) Select commands to be stored as occasion demands.
 - (5) If another storing operation is not continued after storing PC interface commands, the printer enters the online mode (label issue operation) after about 10 seconds. In this case, the image buffer will be cleared automatically.

5.2 LABEL ISSUE OPERATION

An example of the label issue operation is described below.

(1) Where the Saved Data Call Command is not used:

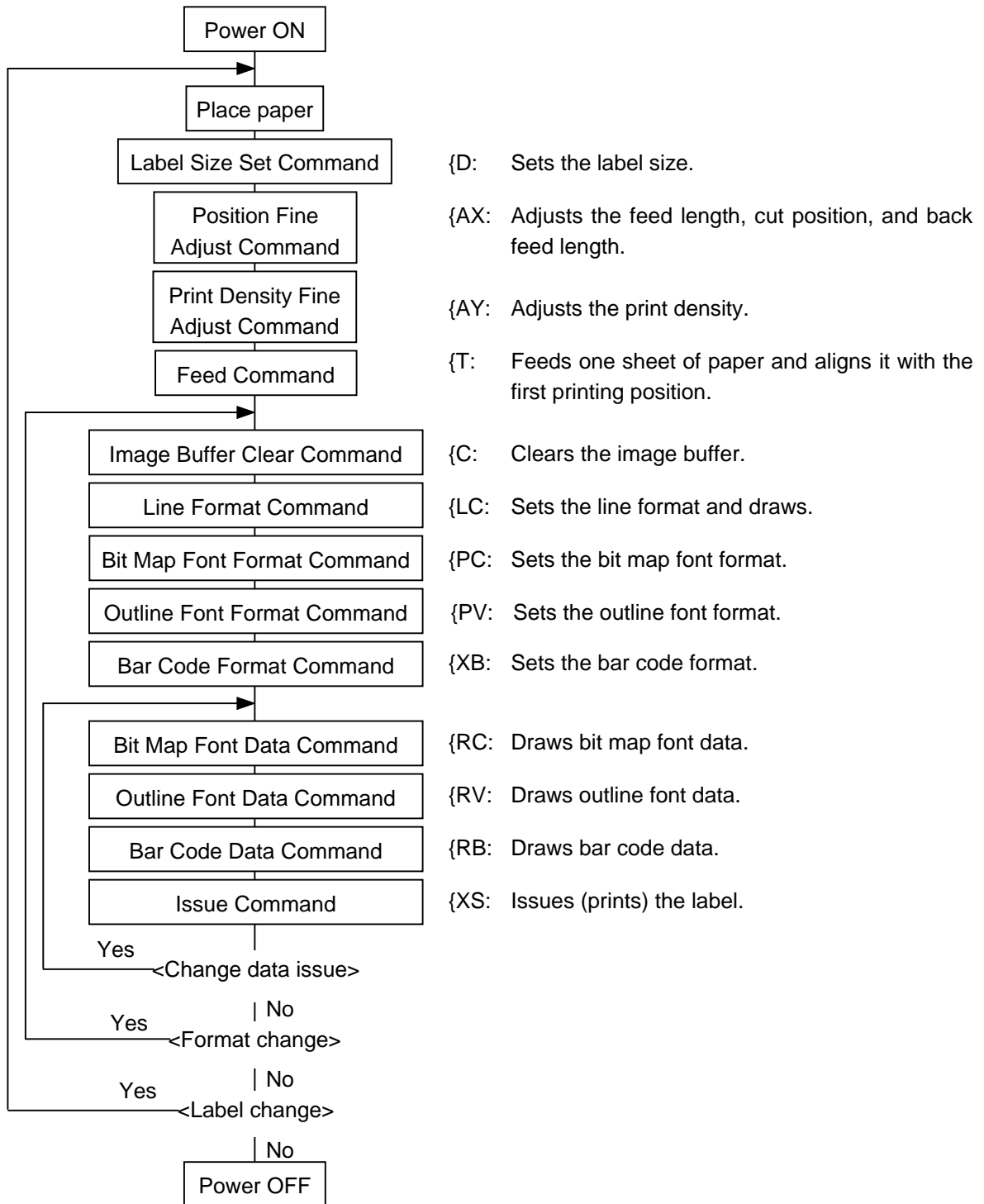

NOTES: (1) When placing new paper, the Label Size Set Command and Feed Command must always be sent. When using the same paper after the power is turned off and then on, the Label Size Set Command and Feed Command may be omitted.

(2) After the power is turned off and then on, the Bit Map Font Format Command, Outline Font Format Command, and Bar Code Format Command should be sent as occasion demands because they are not protected in memory.

(2) Where the Saved Data Call Command is used:

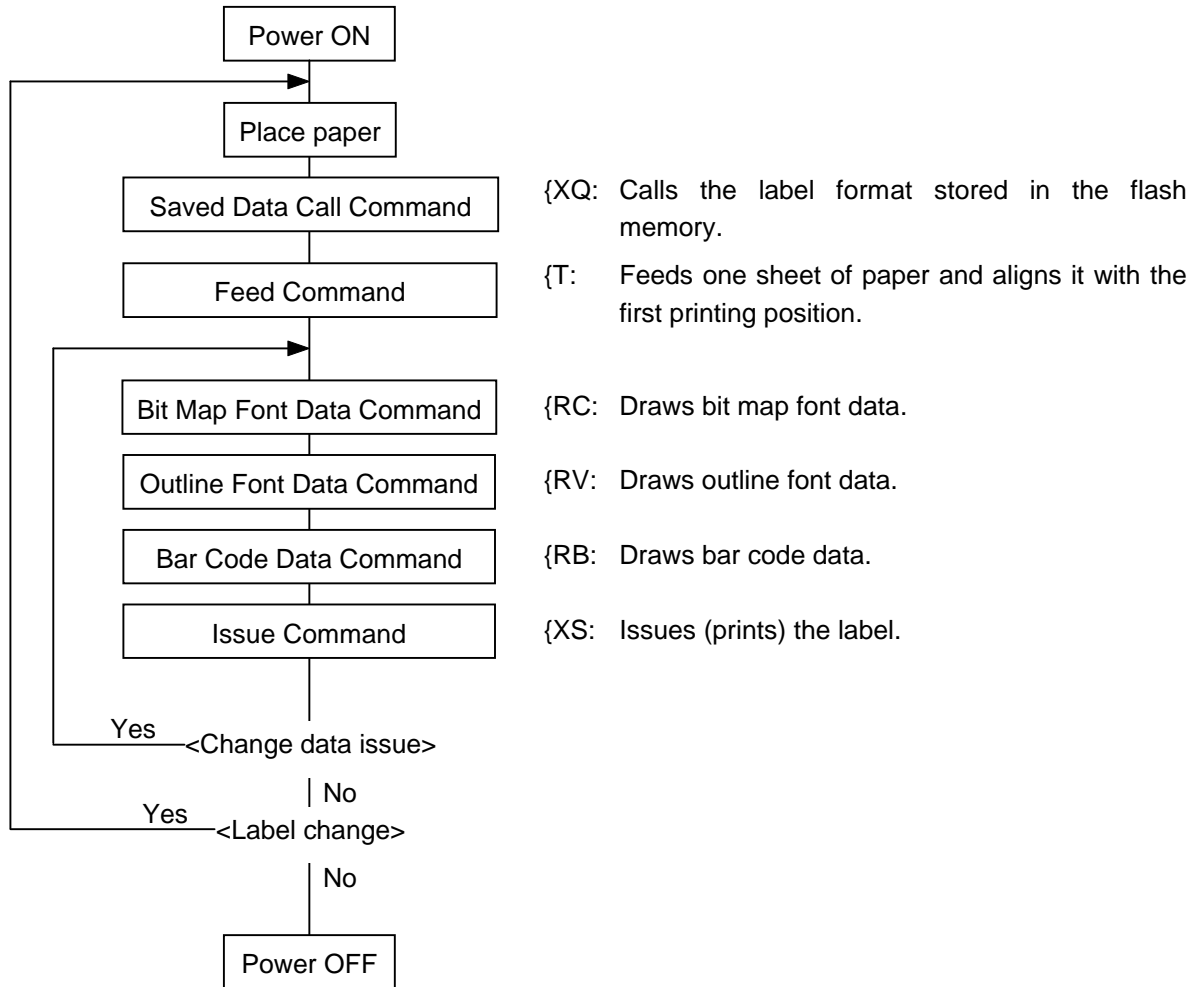

NOTES: (1) When placing new paper, the Feed Command must always be sent. When using the same paper after the power is turned off and then on, the Feed Command may be omitted.

(2) If the option for “automatic call at power on” for the Saved Data Call Command has previously been selected, the Saved Data Call Command may be omitted after the power is turned off and then on.

6. INTERFACE COMMANDS

6.1 OUTLINE OF COMMANDS

(1) Format of Interface command

{	Command & Data		}
---	----------------	--	---

- The length from { to | } must be as specified by each command.
- There are the following two kinds of control codes:
 - ① ESC (1BH), LF (0AH), NUL(00H)
 - ② { (7BH), | (7CH), } (7DH)

(2) How to use reference

Function	Describes the outline of the function of the command.
----------	---

Format	Shows the format of the command.
--------	----------------------------------

The format designation method should conform to the following rules:

- Each set of small letters (such as aa, bbbb) indicates a parameter item.
- An item enclosed in parentheses may be omitted.
- “...” indicates the repetition of an item.
- Brackets and parentheses are used only in coding, and must not be transmitted in practice.
- Other symbols must always be inserted at the designated positions before being transmitted.

Term	Explains the term(s) used in the format. * “0 to 999” described in the entry range indicates that up to 3-digit variable-length entry is allowed. (Entry of “001” or “009” is also possible.) “000 to 999” indicates that entry must be fixed as 3 digits.
------	---

Explanation	Explains the command in detail.
-------------	---------------------------------

Note	Supplementary explanation of the command.
------	---

Refer to	Related commands
----------	------------------

Examples	Explains the command examples.
----------	--------------------------------

{T20C20}

The above corresponds to the transfer of the following:

<u>7B</u>	<u>54</u>	<u>32</u>	<u>30</u>	<u>43</u>	<u>32</u>	<u>30</u>	<u>7C</u>	<u>7D</u>
{	T	2	0	C	2	0		}

(3) Precautions

The commands and parameters described in this specification must always be used. If any command or parameter other than those covered in this specification is used, the printer operation will not be guaranteed. The commands must be used in the online mode. If any command is transmitted in the self-test mode or the maintenance mode, the printer will not operate. However, only the Reset Command can be used.

6.2 LIST OF COMMANDS

(1) Commands related to setting		
6.3 Label Size Set Command	{D.....	28
(2) Commands related to fine adjustment		
6.4 Position Fine Adjust Command	{AX.....	32
6.5 Print Density Fine Adjust Command	{AY.....	37
6.6 Ribbon Motor Drive Voltage Fine Adjust Command	{RM.....	38
(3) Commands related to clear		
6.7 Image Buffer Clear Command	{C.....	39
6.8 Clear Area Command	{XR	40
(4) Commands related to drawing format setting		
6.9 Line Format Command	{LC.....	42
6.10 Bit Map Font Format Command	{PC	48
6.11 Outline Font Format Command	{PV.....	61
6.12 Bar Code Format Command	{XB.....	76
(5) Commands related to print data		
6.13 Bit Map Font Data Command	{RC	106
6.14 Outline Font Data Command	{RV	109
6.15 Bar Code Data Command	{RB	112
(6) Commands related to issue and feed		
6.16 Issue Command	{XS.....	120
6.17 Feed Command	{T	129
6.18 Eject Command	{IB.....	133
6.19 Forward/Reverse Feed Command	{U.....	135
(7) Commands related to writable characters		
6.20 Format Command	{J1.....	137
6.21 2-byte Writable Character Code Range Command	{XE.....	138
6.22 Bit Map Writable Character Command	{XD	139
(8) Commands related to graphics		
6.23 Graphic Command	{SG	148
(9) Commands related to PC command saving		
6.24 Save Start Command	{XO	156
6.25 Save Terminate Command	{XP.....	157
6.26 Saved Data Call Command	{XQ	158
(10) Commands related to control		
6.27 Reset Command	{WR	159
(11) Commands related to status		
6.28 Status Request Command	{WS	160
(12) Others		
6.29 Parameter Set Command	{ZZ.....	161
6.30 Transfer Command (LAN → KB-80)	{MA.....	163
6.31 Transfer Command (KB-80 → LAN)	{NA.....	164
6.32 Storage Area Allocate Command	{XF.....	165

6.3 LABEL SIZE SET COMMAND

{D}

Function	Sets the size of a label or a tag.
Format	{Daaaa, bbbb, cccc}
Term	aaaa: Pitch length of the label or the tag. Fixed as 4 digits (in 0.1 mm units)
	bbbb: Effective print width Fixed as 4 digits (in 0.1 mm units)
	cccc: Effective print length Fixed as 4 digits (in 0.1 mm units)

Explanation

[In the case of labels]

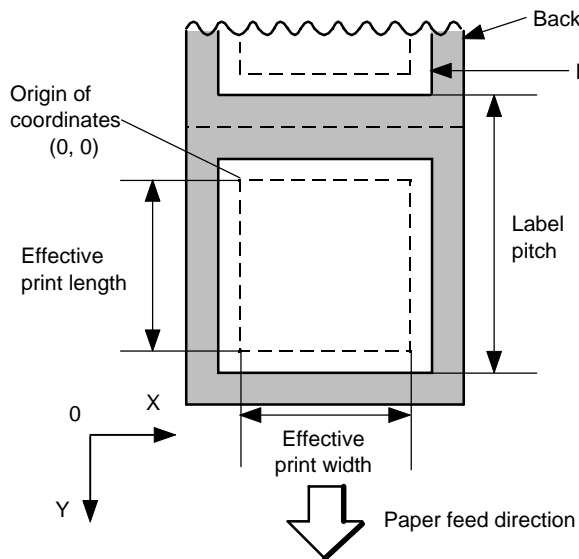

[Print direction: Printing bottom first]

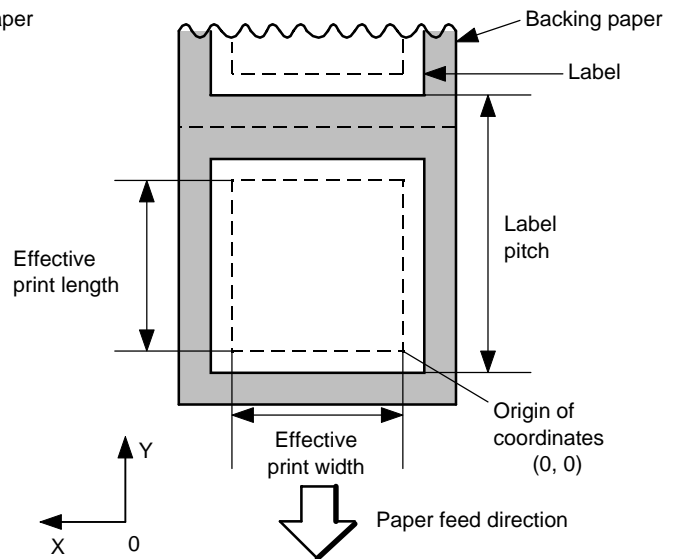

[Printing direction: Printing top first]

[In the case of tags]

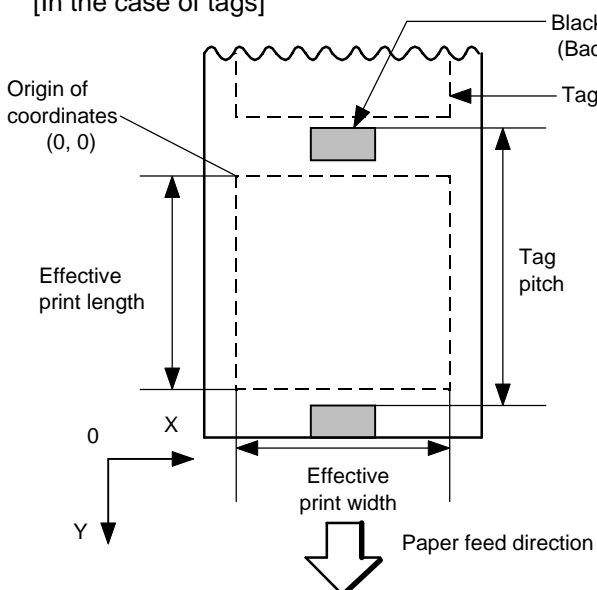

[Print direction: Printing bottom first]

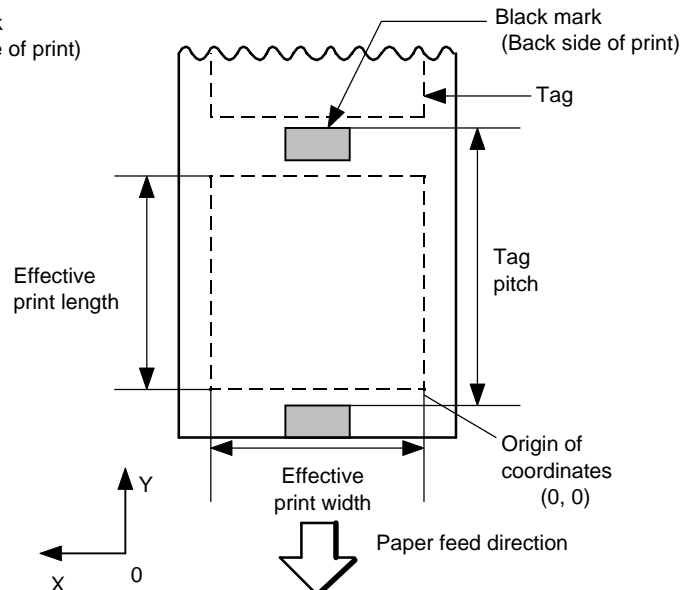

[Printing direction: Printing top first]

[Setting range]

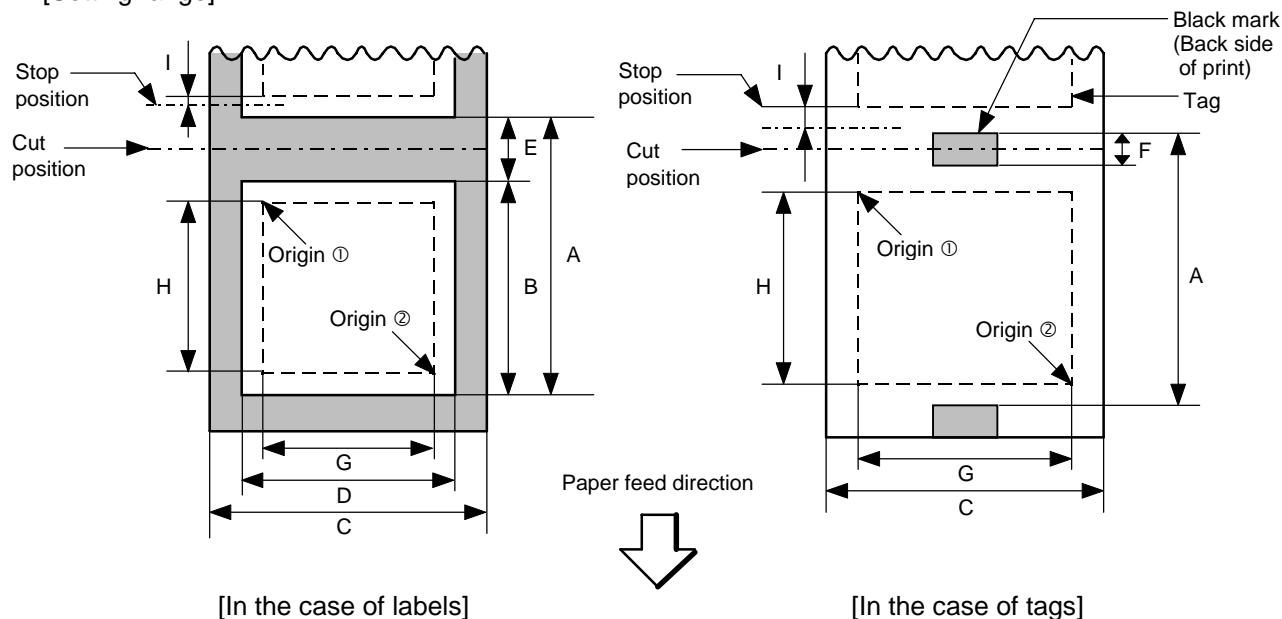

[mm]

Item		Model Method	B-452		
			Batch	Strip	Cut
A: Label pitch Tag pitch	Min.	Label	15.0	25.4	37.0
		Tag	15.0	-	25.4
		Max.	999.0		
B: Label length	Min.		13.0	23.4	31.0
	Max.		997.0		993.0
C: Backing paper width Tag width	Min.		25.4		
	Max.		114.0		
D: Label width	Min.		22.4		
	Max.		111.0		
E: Label-to-label gap	Min.		2.0		6.0
	Max.		20.0		
F: Black mark length	Min.		2.0		
	Max.		10.0		
G: Effective print width	Min.		10.0		
	Max.		105.7		
H: Effective print length	Label	Min.	11.0	21.4	29.0
		Max.	500.0		
	Tag	Min.	13.0	23.4	
		Max.	500.0		
I: Slow-up interval			1.0		

Remark: 1. In cut issue mode, label length B should be as follows:

$$\text{Label length B} \geq 33.0 \text{ mm} - \left(\frac{\text{Label-to-label gap}}{2} \right)$$

Notes

- (1) Before changing the label size or type of sensor, the Label Size Set Command must first be transmitted.
- (2) The Label Size Set Command is protected in memory (even if the power is turned off).
- (3) After sending the Label Size Set Command, one sheet of paper must be fed by the Feed Command ({T) and must be aligned with the first printing position prior to printing.
- (4) The origin of drawing coordinates, print stop position (head position at stop), and cut position are determined according to the parameters of the Label Size Set Command as shown in the figure on the preceding page. For the print stop position in the strip issue mode, refer to the section of the Position Fine Adjust Command. The effective print area is centered on the label/tag.
- (5) Printing cannot be performed in the slow up (1 mm) and slow down (1 mm) areas. Consequently, [A : Label/tag pitch] - [H: Effective print length] \geq 2 mm must be assumed.
- (6) The origin of drawing coordinates, print stop position (head position at stop), and cut position are adjustable by the fine adjust command.
- (7) The tag rotation designation of the Issue Command ({XS) causes the origin of drawing coordinates to be origin ① in the case of “printing bottom first” and to be origin ② in the case of “printing top first”, as shown in the figure.
- (8) The parameters must be as shown in the figure and table. Any value or paper outside the range results in a failure of printing or an error.

Examples

(1) In the case of labels

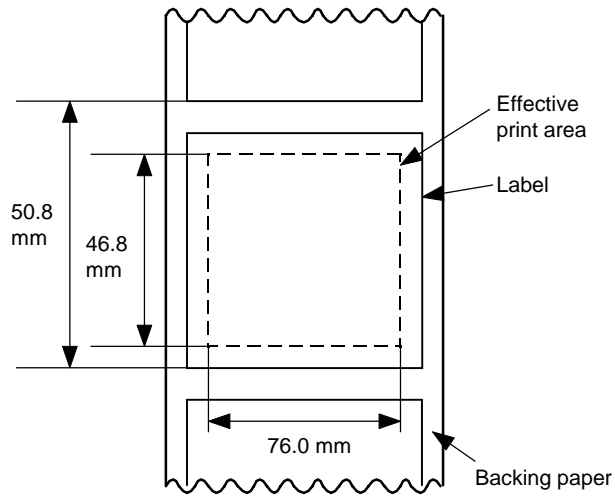

{D0508, 0760, 0468}
{T20C20}

(2) In the case of tags

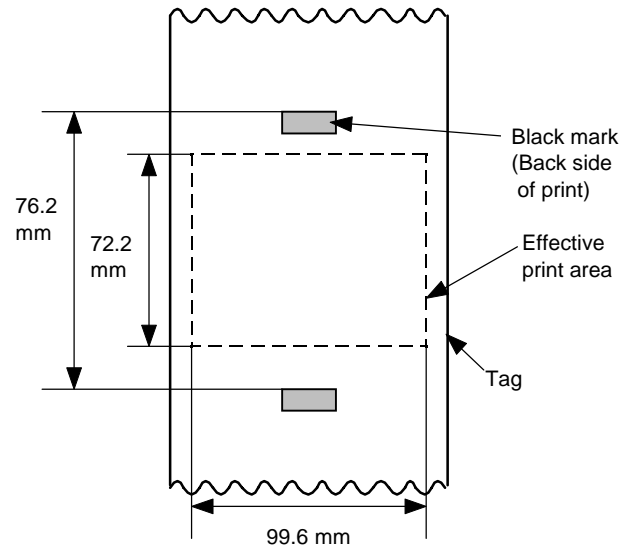

{D0762, 0996, 0722}
{T10C20}

6.4 POSITION FINE ADJUST COMMAND

{AX

Function	Adjusts the feed value so that the label will be shifted forward or backward from the automatically set first printing position. Adjusts the cut position so that the label will be cut at a position shifted forward or backward from the automatically set cut position. Adjusts the value for feeding back the label to the home position after cutting. Adjusts the strip position so that the label will be shifted forward or backward from the automatically set strip position. Adjusts the value for feeding back the label to the home position after stripping. Sets the correction value for print shrinkage.
Format	{AX; abbb, cddd, eff (, ghhh)}
Term	<p>a: Indicates the direction, forward or backward, in which a fine adjustment is to be made. +: Backward -: Forward</p> <p>bbb: Feed value to be finely adjusted. 000 to 100 (in 0.1 mm units)</p> <p>c: Indicates the direction, forward or backward, in which a cut position (or strip position) fine adjustment is to be made. +: Backward -: Forward</p> <p>ddd: Amount for finely adjusting the cut position (or strip position). 000 to 100 (in 0.1 mm units)</p> <p>e: Indicates whether the back feed is to be increased or decreased. +: Increase -: Decrease</p> <p>ff: Amount for finely adjusting the back feed. 00 to 99 (in 0.1 mm units)</p> <p>g: Indicates whether the correction value is to be increased or decreased. +: Increase -: Decrease</p> <p>hhh: Print shrinkage correction value 000 to 100 (in 0.1% units)</p>

Explanation

[Feed Length Fine Adjustment] (To finely adjust the feed for shifting backward or forward)

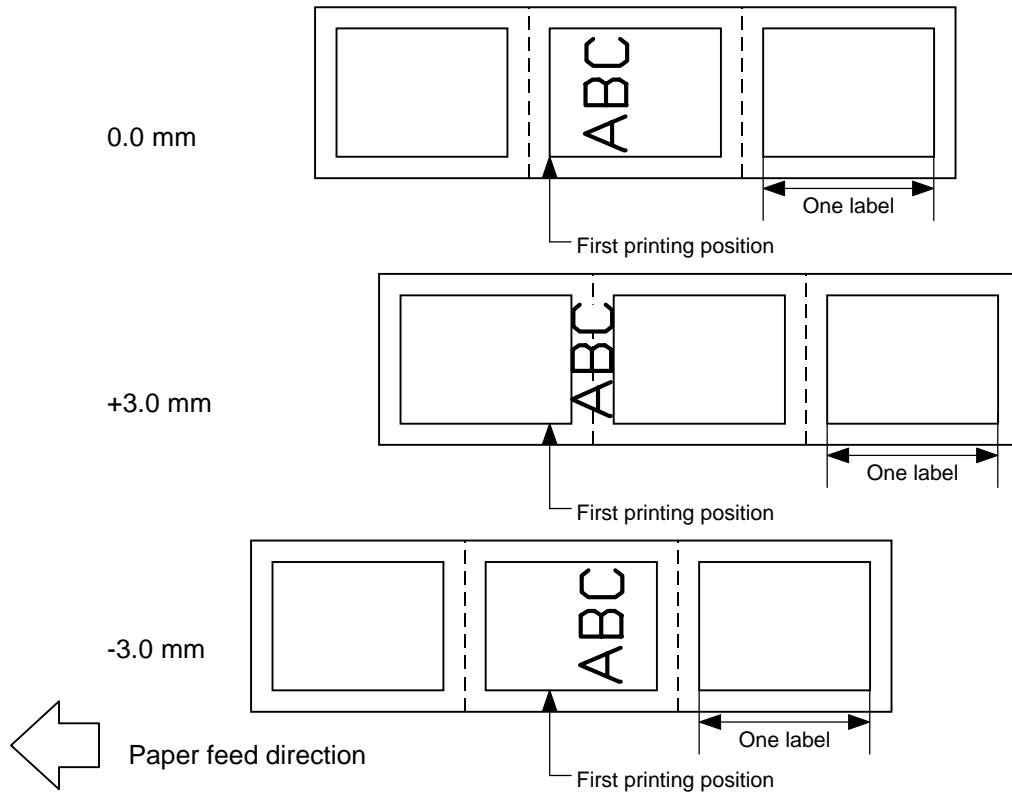

[Cut Position Fine Adjustment] (To finely adjust the cut position for shifting backward or forward)

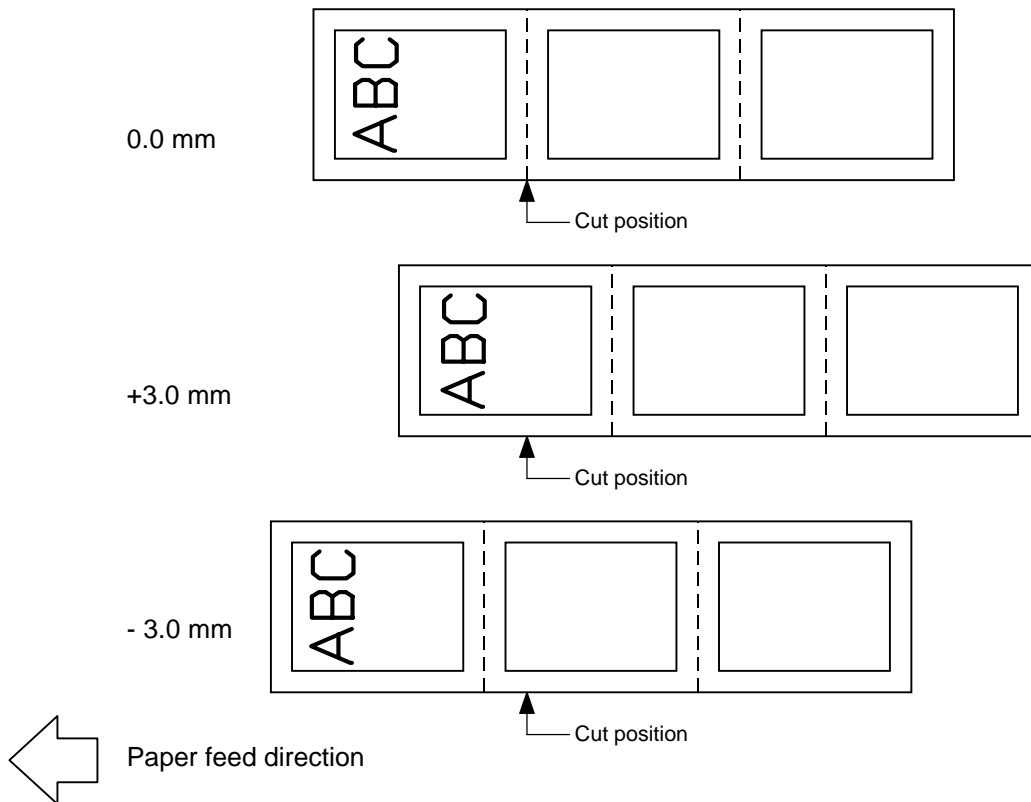

[Strip Position Fine Adjustment]

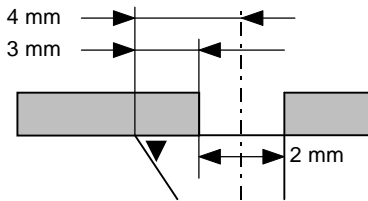
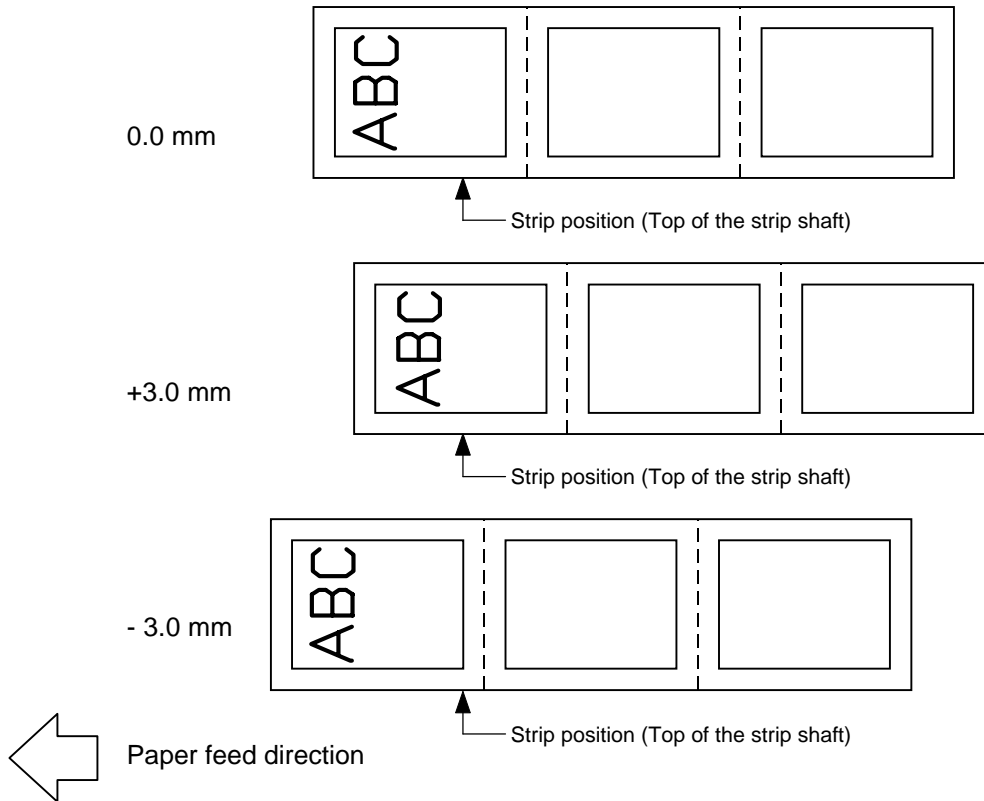

Printing in strip issue mode is stopped at the position where the distance from the middle point of the label-to-label gap to the top of the strip shaft is 4 mm, since the label-to-label gap is assumed to be 2 mm.

When the print stop position is not proper, the print stop position should be adjusted using the strip position fine adjust function. When the label-to-label gap is 5 mm or more, the effective print length should be set to the maximum (label pitch -2 mm). Then, the print stop position should be adjusted using the strip position fine adjust function.

[Back Feed Fine Adjustment] (To finely adjust the back feed for shifting backward or forward)

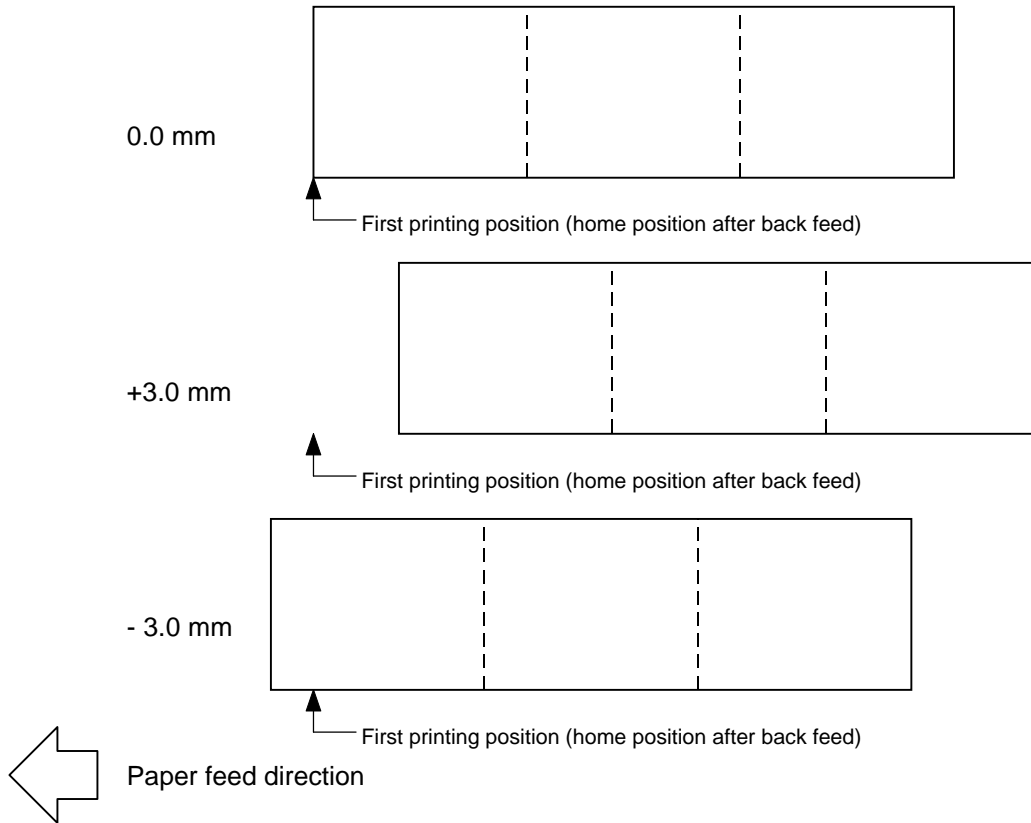

Notes

- (1) After changing the fine adjustment value by this command, one label must be fed by the Feed Command ({T) to adjust the first printing position.
- (2) Each fine adjustment value is protected in memory (even if the power is turned off).
- (3) If a fine adjustment value is improper, printing will not be performed correctly.
(For example, if the back feed fine adjustment value is not set properly, the printing positions without cutting and after cutting will be different from each other. If the label is fed back too far, the paper will not be fed correctly during printing.
In the strip issue mode, the print position of the 1st label may be different from that of the 2nd label. The back feed adjustment is performed in order that the label is correctly fed back to the position placed before the forward feed is performed.)
- (4) The cut position (or the strip position) fine adjustment and back feed fine adjustment are effective only when the printer is in the cut issue mode or strip issue mode.
- (5) If +33.0 mm or more is set for the cut position adjustment when the print position fine adjustment value is 0.0 mm, it is recognized as +33.0 mm.
(The cut position fine adjustment is to adjust the moving distance from the stop position to the cutter so that the distance from head to cutter is 33.0 mm.)

Examples (1) Cut issue

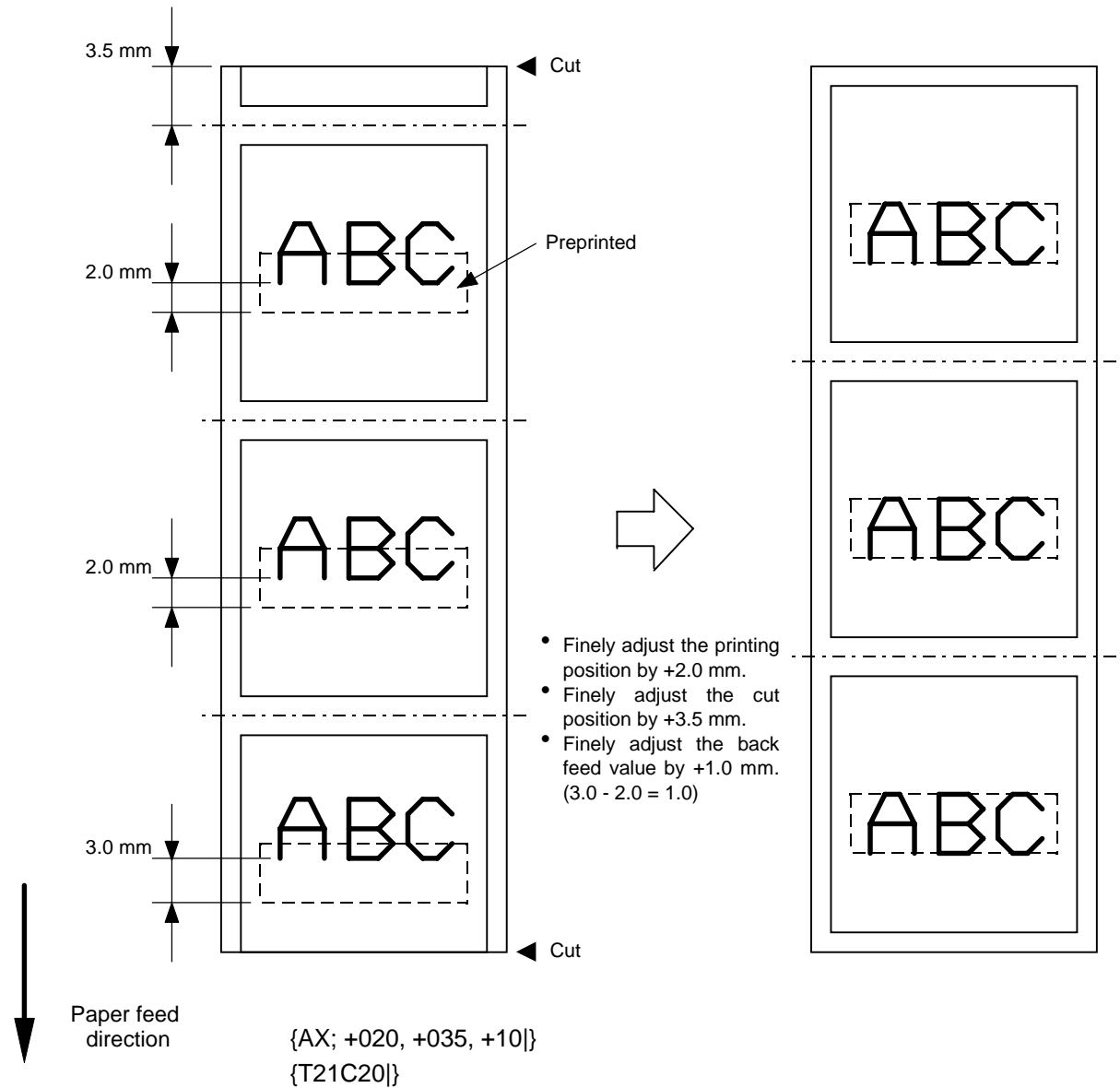

(2) Strip issue

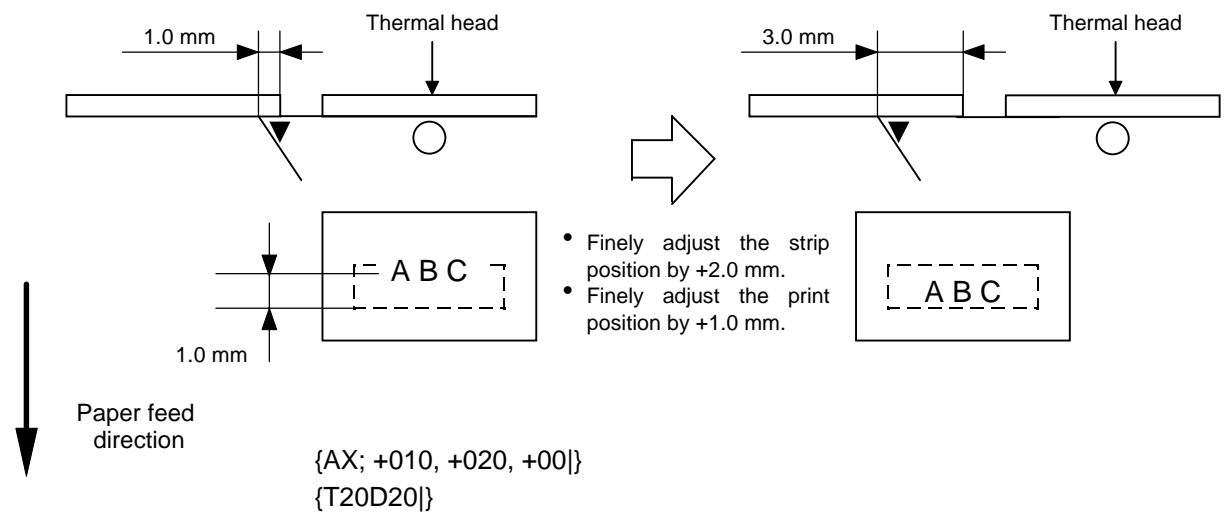

6.5 PRINT DENSITY FINE ADJUST COMMAND

{AY

Function	Adjusts the automatically set print density.
Format	{AY; abb, c}
Term	a: Indicates whether to increase or decrease the density. +: Increase (darker) - : Decrease (lighter) bb: Print density fine adjustment value 00 to 10 (in units of 1 step) c: Indicates the mode for fine adjustment, thermal transfer or direct thermal. 0: Thermal transfer 1: Direct thermal
Explanation	(1) The Print Density Fine Adjust Command is protected in memory (even if the power is turned off). (2) The fine adjustment value is 00 at the time of shipment from the factory.
Examples	To set the density in direct thermal mode to -2. {AY; -02, 1}

6.6 RIBBON MOTOR DRIVE VOLTAGE FINE ADJUST COMMAND {RM

Function	Adjusts the voltage of the ribbon motor.
Format	{RM; abcdd}
Term	<p>a: Fine adjustment direction of the ribbon rewind motor -: Negative (The voltage is lowered.)</p> <p>bb: Fine adjustment value for the ribbon rewind motor 00 to 15 (in units of 1 step)</p> <p>c: Fine adjustment direction of the ribbon back tension motor -: Negative (The voltage is lowered.)</p> <p>dd: Fine adjustment value for the ribbon back tension motor 00 to 15 (in units of 1 step)</p>
Explanation	<p>(1) -1 step corresponds to -5% of the standard voltage.</p> <p>(2) The ribbon motor drive voltage fine adjustment value is protected in memory (even if the power is turned off).</p> <p>(3) When the RAM clear is performed, the fine adjustment values for fine adjust commands (rewind and back tension) are "00".</p> <p>(4) The fine adjustment values for fine adjust commands (rewind and back tension) are "00" at the time of shipment from the factory.</p>
Example	<p>To set the value for the ribbon rewind motor to -3, and the value for the ribbon back tension motor to -2.</p> <pre>{RM; -03-02} {XS; I, 0001, 0002C2100}</pre>

6.7 IMAGE BUFFER CLEAR COMMAND

{C}

Function	Clears the image buffer for drawing characters, lines, bar codes, and graphics.
Format	{C}
Explanation	<ol style="list-style-type: none">(1) After changing the label size, the image buffer must be cleared.(2) The increment/decrement designation is valid until the Image Buffer Clear Command is transmitted.(3) The link field designation is effective until the Image Buffer Clear Command is sent.
Examples	<pre>{C} {RC000; ABC} {RC001; DEF} {XS; I, 0001, 0002C2000}</pre>

6.8 CLEAR AREA COMMAND

{XR}

Function	Clears the designated area or reverses the white/black dot pattern in the designated area in the drawing area.
Format	{XR; aaaa, bbbb, cccc, dddd, e}
Term	<p>aaaa: Designated area start point X-coordinate Fixed as 4 digits (in 0.1 mm units)</p> <p>bbbb: Designated area start point Y-coordinate Fixed as 4 digits (in 0.1 mm units)</p> <p>cccc: Designated area end point X-coordinate Fixed as 4 digits (in 0.1 mm units)</p> <p>dddd: Designated area end point Y-coordinate Fixed as 4 digits (in 0.1 mm units)</p> <p>e: Type of clear A: Clears the contents in the designated area to zeros. B: Reverses the white/black dot pattern in the designated area.</p>

Explanation

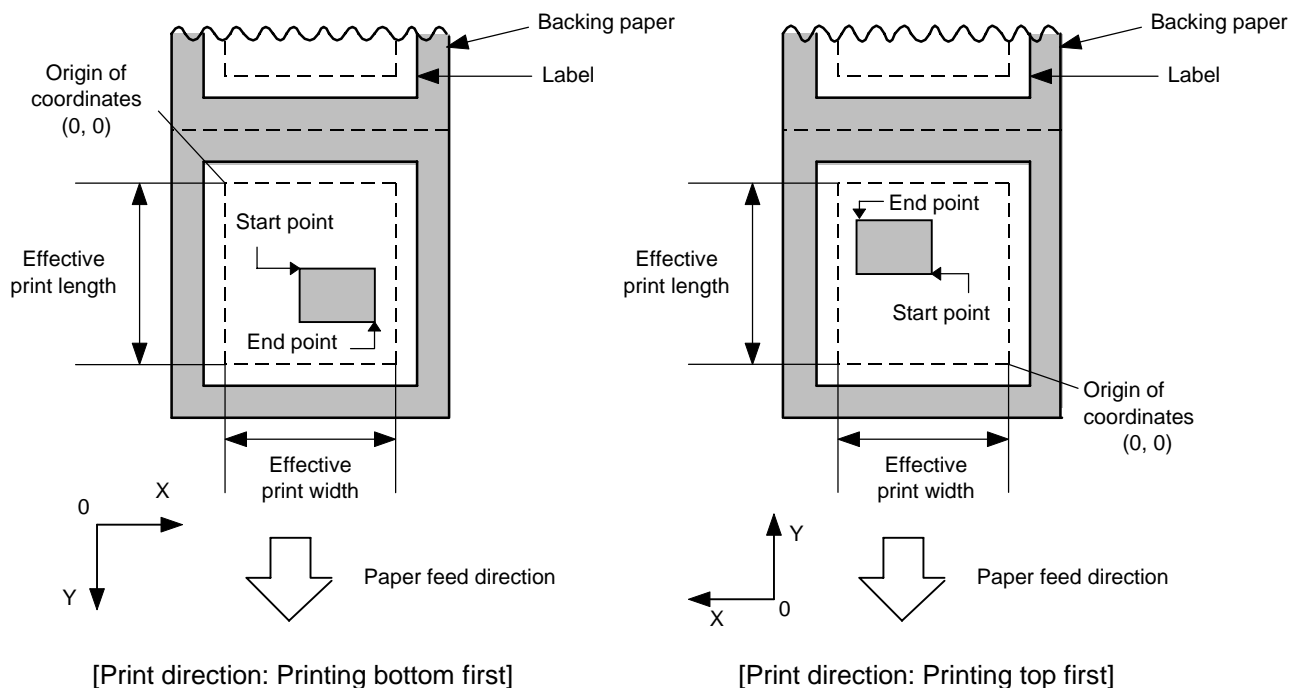

Notes	<ol style="list-style-type: none"> (1) The result is the same even if the start and end point coordinates are reversed. (2) The result is the same even if the start and end point coordinates are set to an upper right and a lower left points, respectively. (3) The start and end coordinates of the designated area must be set within the effective print area set by the Label Size Set Command ({D}).
-------	--

[Effective print area]

[mm]

Item		Model	B-452		
		Method	Batch	Strip	Cut
Effective print width		Min.	10.0		
		Max.	105.7		
Effective print length	Label	Min.	11.0	21.4	29.0
		Max.	500.0		
	Tag	Min.	13.0	23.4	
		Max.	500.0		

Examples

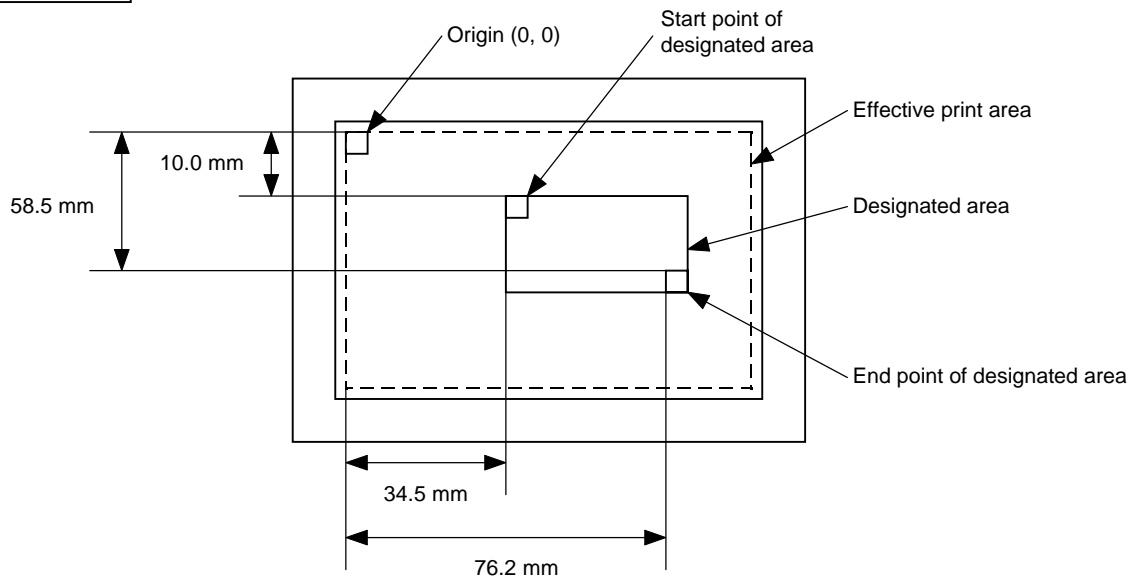

{XR; 0345, 0100, 0762, 0585, A}

{RC000; ABC}

{RC001; DEF}

{XS; I, 0001, 0002C2000}

6.9 LINE FORMAT COMMAND

{LC

Function	Sets the line format and draws the line.
Format	{LC; aaaa, bbbb, cccc, dddd, e, f (, ggg)}
Term	<p>aaaa: Start point X-coordinate Fixed as 4 digits (in 0.1 mm units)</p> <p>bbbb: Start point Y-coordinate Fixed as 4 digits (in 0.1 mm units)</p> <p>cccc: End point X-coordinate Fixed as 4 digits (in 0.1 mm units)</p> <p>dddd: End point Y-coordinate Fixed as 4 digits (in 0.1 mm units)</p> <p>e: Type of line 0: Line (horizontal, vertical line, slant line) 1: Rectangle 2: Jagged line (vertical, horizontal) 3: Rectangle with jagged lines</p> <p>f: No. of line width dots 1 to 9 (in 0.1 mm units)</p> <p>ggg: Radius of rounded corners of a rectangle (omissible) Fixed as 3 digits (in 0.1 mm units)</p>

Explanation

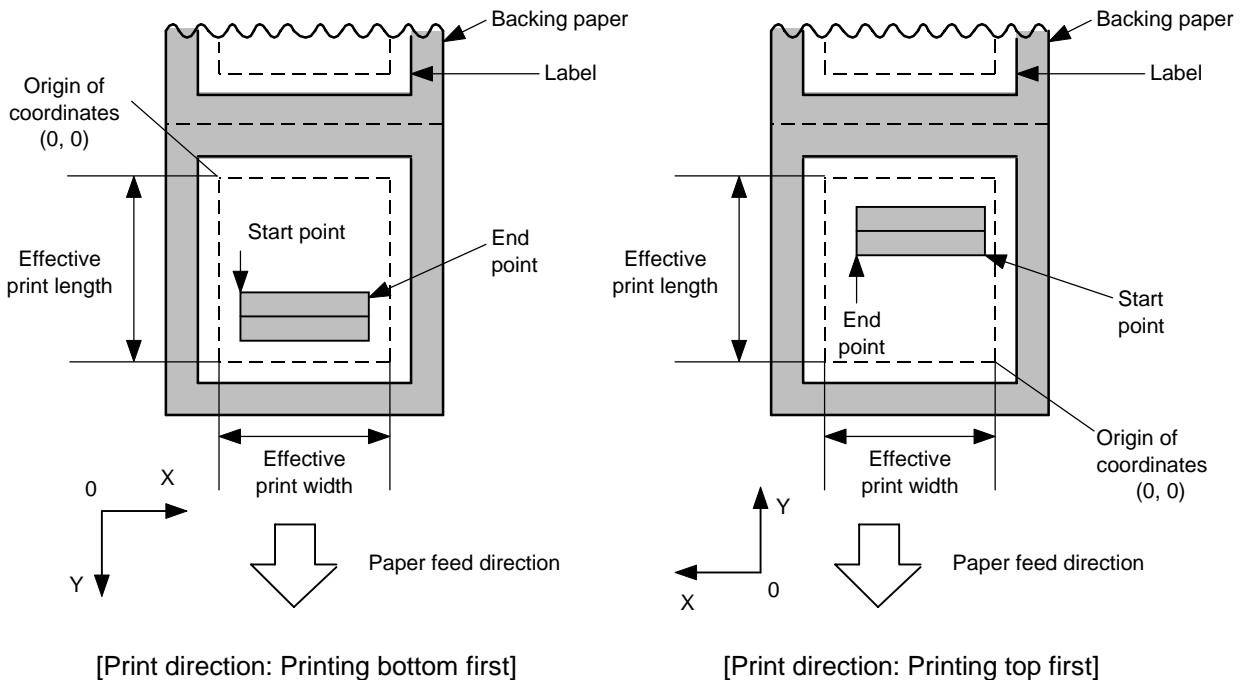

[Line]

- (1) Horizontal line (In the case of $|Y_2 - Y_1| = 0$)

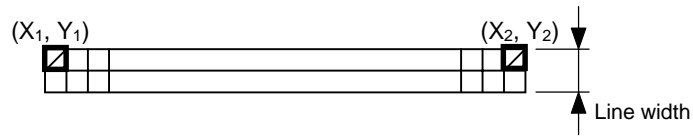

- (2) Vertical line (In the case of $|X_2 - X_1| = 0$)

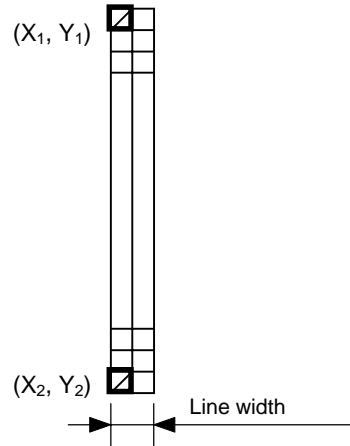

- (3) Slant line A ($|X_2 - X_1| \leq |Y_2 - Y_1|$)

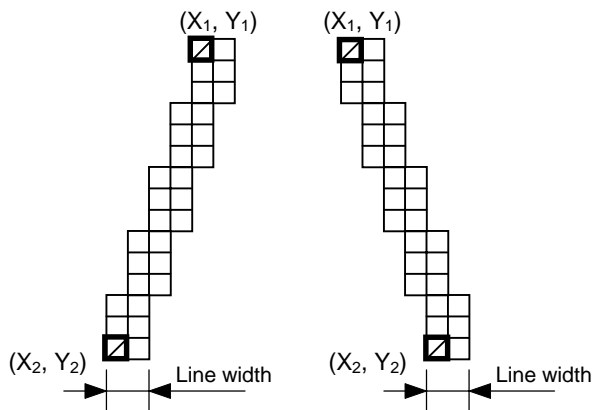

- (4) Slant line B ($|X_2 - X_1| > |Y_2 - Y_1|$)

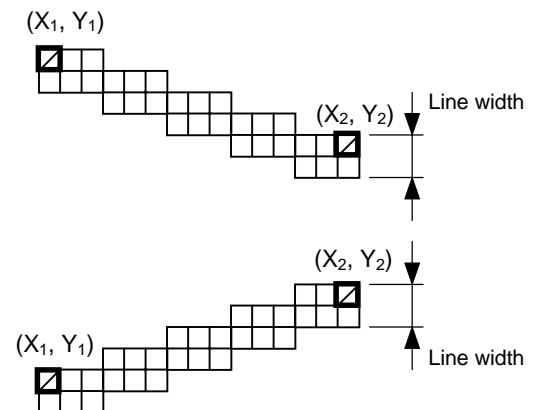

[Rectangle]

(1) Radius of rounded corners = 000 or parameter omitted

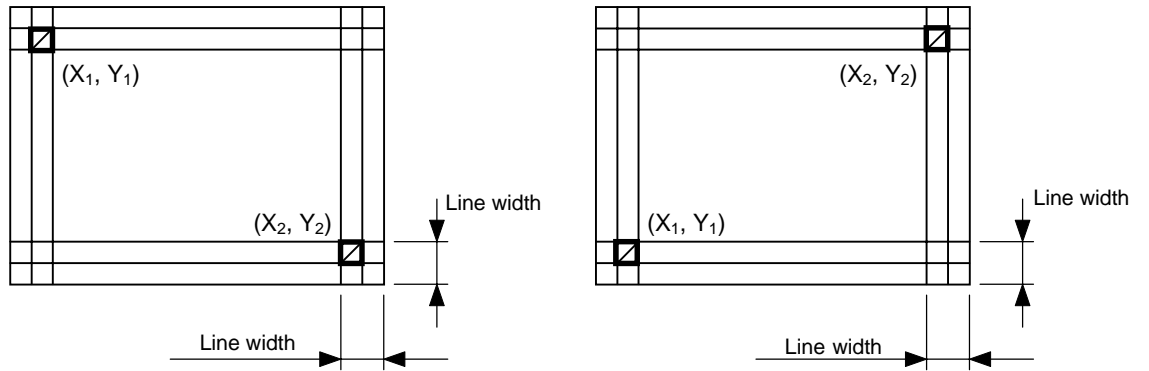

(2) Radius of rounded corners \neq 000

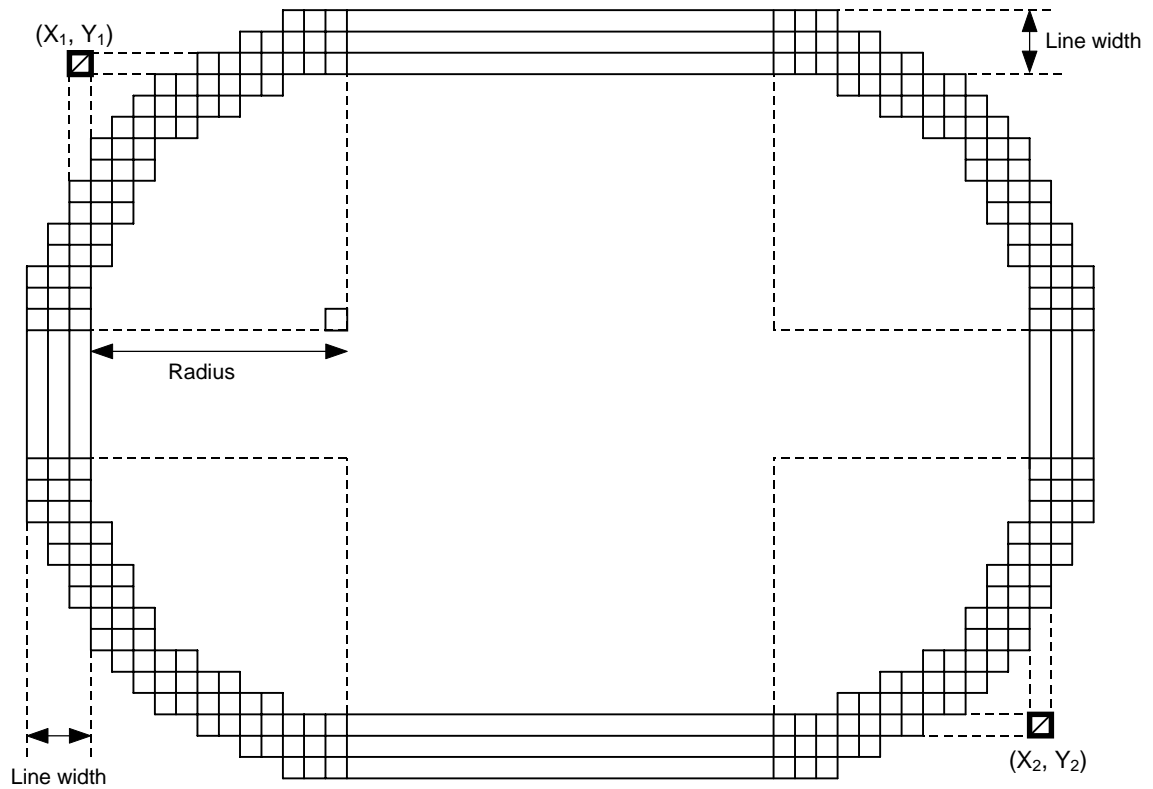

[Jagged Line]

- (1) Horizontal line

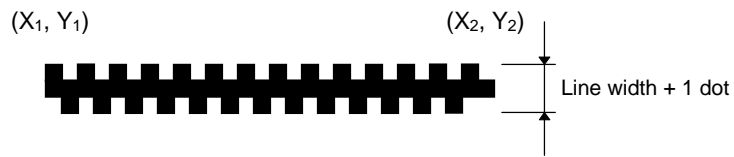

Both the upper and lower sides of the line are jagged.
As the line width becomes larger, the center of the line (not jagged) becomes wider.

- (2) Vertical line

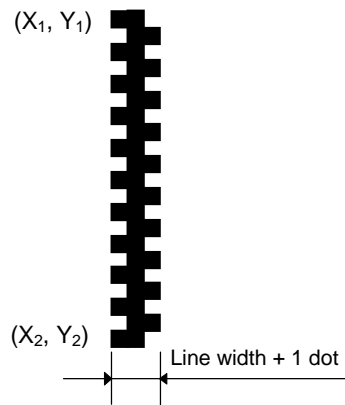

Both the left and right sides of the line are jagged.
As the line width becomes larger, the center of the line (not jagged) becomes wider.

[Rectangle]

- (1) Radius of rounded corners = 000, or a parameter is omitted.

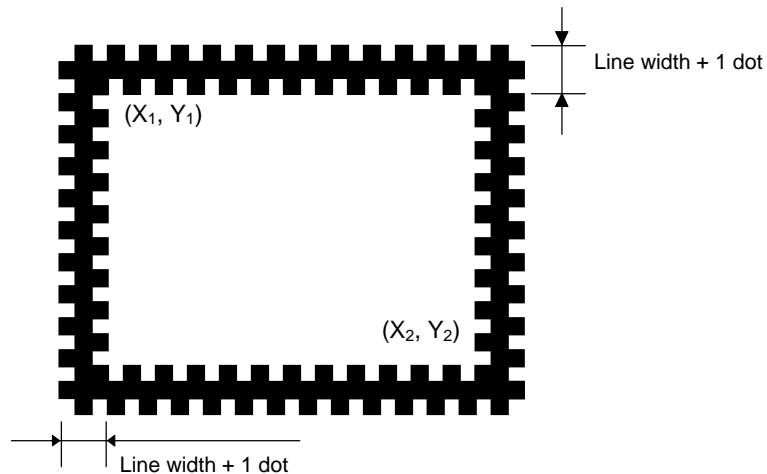

Both the right and left sides of the line, or both the upper and lower sides of the line are jagged. As the line width becomes larger, the center of the line (not jagged) becomes wider.

(2) Radius of rounded corners ≠000

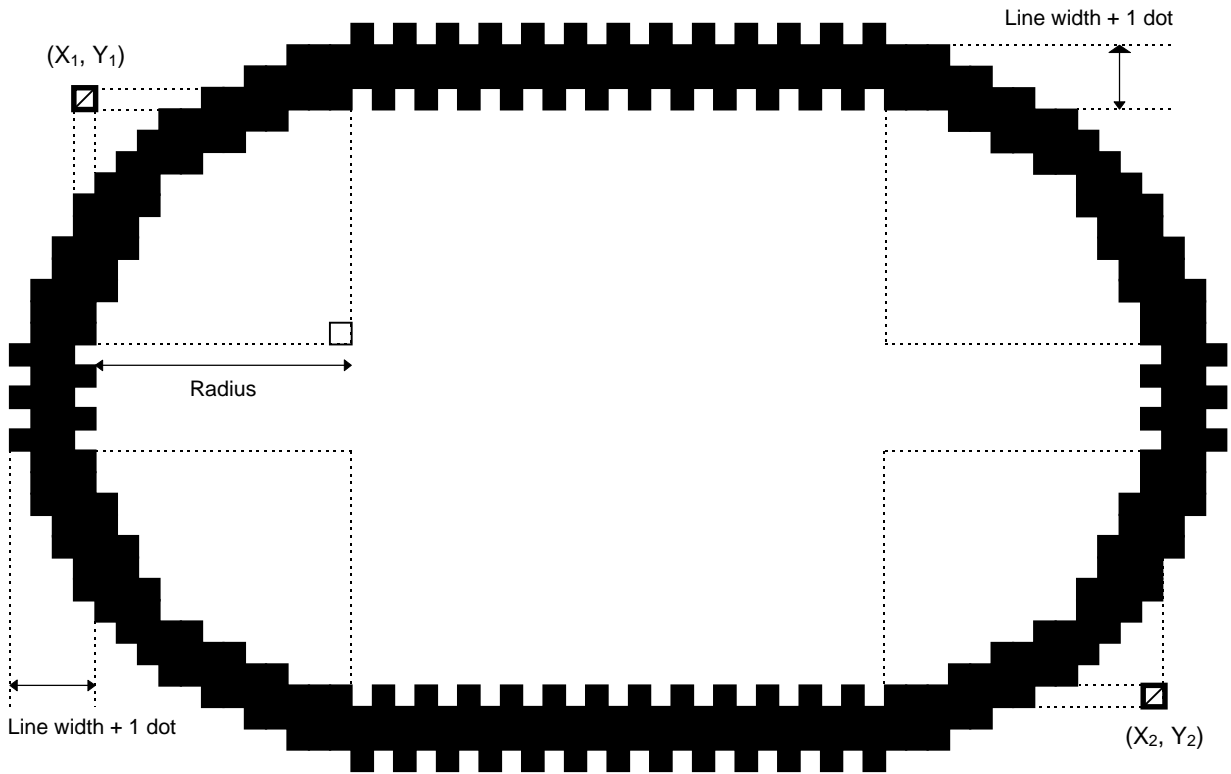

Notes

- (1) In line designation, a horizontal line, vertical line or slant line A/B is drawn according to the start and end point coordinates.
- (2) The result is the same even if the start and end point coordinates are reversed.
- (3) The start and end point coordinates must be set so that the result of line drawing will be within the effective print area set by the Label Size Set Command ({D}).
- (4) Programming the radius of the rounded corner is effective only when the type of line is 1 (Rectangle). When the type of line is 0, designation of the radius is ignored.
When the type of line is 1, and the radius of the rounded corner is 000 or omitted, a rectangle is printed.
- (5) A circle is assumed when:

$$\frac{|X_2 - X_1|}{2} = \frac{|Y_2 - Y_1|}{2} \leq [\text{Radius of rounded corners}]$$

[Effective print area]

[mm]

Item	Model	B-452			
		Method	Batch	Strip	Cut
Effective print width	Min.	10.0			
	Max.	105.7			
Effective print length	Label	Min.	11.0	21.4	29.0
		Max.	500.0		
	Tag	Min.	13.0	23.4	
		Max.	500.0		

Examples

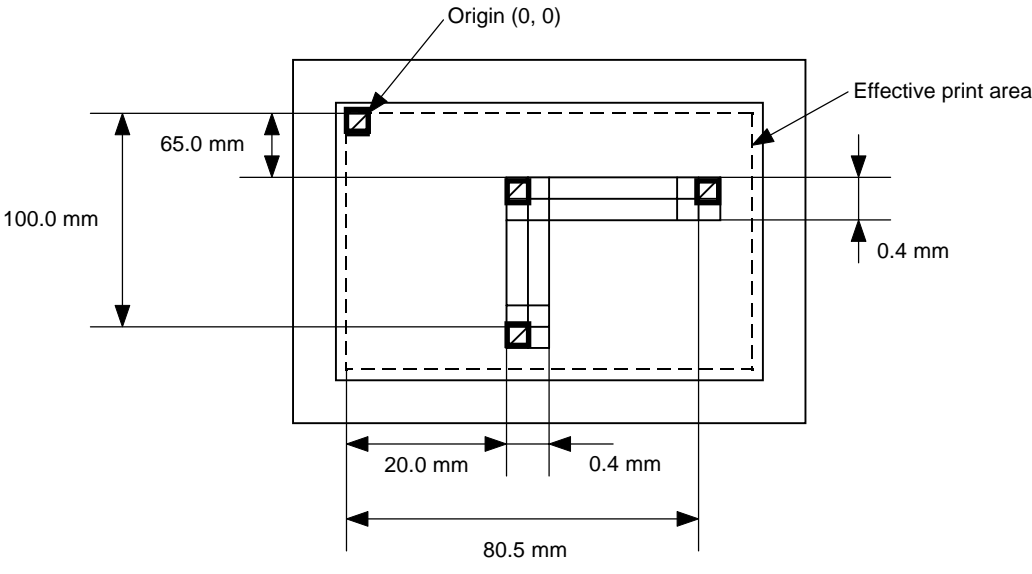

```
{C}  
{LC; 0200, 0650, 0805, 0650, 0, 4}  
{LC; 0200, 0650, 0200, 1000, 0, 4}  
{XS; I, 0001, 0002C2000}
```

6.10 BIT MAP FONT FORMAT COMMAND

{PC

Function	Sets the format indicating on the label at which the bit map font is to be printed and how it is to be printed.																																																												
Format	<p>① {PCaaa; bbbb, cccc, d, e, ff (, gh), ii, j (, Jkkl) (, Mm) (, noooooooooo) (, Zpp) (, Pq) (=rrr-----rrr) }</p> <p>② {PCaaa; bbbb, cccc, d, e, ff (, gh), ii, j (, Jkkl) (, Mm) (, noooooooooo) (, Zpp) (, Pq) (; ss₁, ss₂, ss₃, -----, ss₂₀) }</p>																																																												
Term	<p>aaa: Character string number 000 to 199 (two digits, 00 to 99, also acceptable)</p> <p>bbbb: Print origin of X-coordinate of character string Fixed as 4 digits (in 0.1 mm units)</p> <p>cccc: Print origin of Y-coordinate of character string Fixed as 4 digits (in 0.1 mm units)</p> <p>d: Character horizontal magnification 1 to 9 (in magnifications)</p> <p>* Two digit designation enables magnifications in 0.5 units (05 ~ 95: 0.5 to 9.5 magnifications). The magnification can be designated in 0.1 units between 0.5 to 1. (06 ~ 09: 0.6 to 0.9 magnifications).</p> <p style="margin-left: 20px;">d d └─┬─┘ Designation in 0.5 magnification units : 0 or 5 (5 to 9, up to 1 magnification) └───┘ Designation in magnifications : 0 to 9</p> <p>e: Character vertical magnification 1 to 9 (in magnifications)</p> <p>* Two digit designation enables magnifications in 0.5 units (05 ~ 95: 0.5 to 9.5 magnifications). The magnification can be designated in 0.1 units between 0.5 to 1. (06 ~ 09: 0.6 to 0.9 magnifications).</p> <p style="margin-left: 20px;">e e └─┬─┘ Designation in 0.5 magnification units : 0 or 5 (5 to 9, up to 1 magnification) └───┘ Designation in magnifications : 0 to 9</p> <p>ff: Type of font</p> <table style="margin-left: 20px;"> <tr><td>A:</td><td>Times Roman</td><td>(Medium)</td><td>8 point</td></tr> <tr><td>B:</td><td>Times Roman</td><td>(Medium)</td><td>10 point</td></tr> <tr><td>C:</td><td>Times Roman</td><td>(Bold)</td><td>10 point</td></tr> <tr><td>D:</td><td>Times Roman</td><td>(Bold)</td><td>12 point</td></tr> <tr><td>E:</td><td>Times Roman</td><td>(Bold)</td><td>14 point</td></tr> <tr><td>F:</td><td>Times Roman</td><td>(Italic)</td><td>12 point</td></tr> <tr><td>G:</td><td>Helvetica</td><td>(Medium)</td><td>6 point</td></tr> <tr><td>H:</td><td>Helvetica</td><td>(Medium)</td><td>10 point</td></tr> <tr><td>I:</td><td>Helvetica</td><td>(Medium)</td><td>12 point</td></tr> <tr><td>J:</td><td>Helvetica</td><td>(Bold)</td><td>12 point</td></tr> <tr><td>K:</td><td>Helvetica</td><td>(Bold)</td><td>14 point</td></tr> <tr><td>L:</td><td>Helvetica</td><td>(Italic)</td><td>12 point</td></tr> <tr><td>M:</td><td>Presentation</td><td>(Bold)</td><td>18 point</td></tr> <tr><td>N:</td><td>Letter Gothic</td><td>(Medium)</td><td>9.5 point</td></tr> <tr><td>O:</td><td>Prestige Elite</td><td>(Medium)</td><td>7 point</td></tr> </table>	A:	Times Roman	(Medium)	8 point	B:	Times Roman	(Medium)	10 point	C:	Times Roman	(Bold)	10 point	D:	Times Roman	(Bold)	12 point	E:	Times Roman	(Bold)	14 point	F:	Times Roman	(Italic)	12 point	G:	Helvetica	(Medium)	6 point	H:	Helvetica	(Medium)	10 point	I:	Helvetica	(Medium)	12 point	J:	Helvetica	(Bold)	12 point	K:	Helvetica	(Bold)	14 point	L:	Helvetica	(Italic)	12 point	M:	Presentation	(Bold)	18 point	N:	Letter Gothic	(Medium)	9.5 point	O:	Prestige Elite	(Medium)	7 point
A:	Times Roman	(Medium)	8 point																																																										
B:	Times Roman	(Medium)	10 point																																																										
C:	Times Roman	(Bold)	10 point																																																										
D:	Times Roman	(Bold)	12 point																																																										
E:	Times Roman	(Bold)	14 point																																																										
F:	Times Roman	(Italic)	12 point																																																										
G:	Helvetica	(Medium)	6 point																																																										
H:	Helvetica	(Medium)	10 point																																																										
I:	Helvetica	(Medium)	12 point																																																										
J:	Helvetica	(Bold)	12 point																																																										
K:	Helvetica	(Bold)	14 point																																																										
L:	Helvetica	(Italic)	12 point																																																										
M:	Presentation	(Bold)	18 point																																																										
N:	Letter Gothic	(Medium)	9.5 point																																																										
O:	Prestige Elite	(Medium)	7 point																																																										

P: Prestige Elite (Bold) 10 point
 Q: Courier (Medium) 10 point
 R: Courier (Bold) 12 point
 S: OCR-A 12 point
 T: OCR-B 12 point

* The following fonts are proportional.
 A, B, C, D, E, F, G, H, I, J, K, L

01: Writable character 1 (1×1 dot to 720×720 dots)
 to
 40: Writable character 40 (1×1 dot to 720×720 dots)
 51: Writable character 51 (1×1 dot to 720×720 dots) (2-byte code set)

ghh: Fine adjustment of character-to-character space (omissible)
 g: Designates whether to increase or decrease the character-to-character space.
 +: Increase
 -: Decrease

hh: No. of space dots between characters
 00 to 99 (in dots)

ii: Rotational angles of a character and character string
 00: 0° (char.) 0° (char.-string)
 11: 90° (char.) 90° (char.-string)
 22: 180° (char.) 180° (char.-string)
 33: 270° (char.) 270° (char.-string)

j: Character attribution

B: Black character
 W (aabb): Reverse character

aa: No. of dots from the character string to the end of the black background in the horizontal direction.

bb: No. of dots from the character string to the end of the black background in the vertical direction.

aa: 01 to 99 (in units of dots)

bb: 01 to 99 (in units of dots)

F (aabb): Boxed character

aa: No. of dots from the character string area to the box in the horizontal direction.

bb: No. of dots from the character string area to the box in the vertical direction.

aa:01 to 99 (in units of dots)

bb:01 to 99 (in units of dots)

C (aa): Stroked out character

aa: No. of dots from the character string area to the end of the stroke

aa: 01 to 99 (in units of dots)

* Descriptions in parentheses are omissible.
 (If omitted, it is magnification × 6 dots.)

Jkkl: Designates a bold character (omissible).

kk: No. of horizontal shift dots
 00 to 16 (in dots)

ll: No. of vertical shift dots
 00 to 16 (in dots)

Mm: Type of the check digit to be attached (omissible)
m: Type of check digit
0: Modulus 10 (Draws data and check digit)
1: Modulus 43 (Draws data and check digit)
2: DBP Modulus 10 (Draws check digit only)

nooooooooo: Increment and decrement (omissible)
n: Designates whether to increment or decrement.
+: Increment
-: Decrement
oooooooo: Skip value
0000000000 to 9999999999

Zpp: Zero suppression (omissible)
pp: No. of zeros to be suppressed
00 to 20

Pq: Alignment
q: Designates the character position
1: Left
2: Center
3: Right
4aaaa: Equal space
aaaa: X direction of character string area
0050 to 1057 (in 0.1 mm units)

5aaaabbbcc: Automatic line feed
aaaa: X direction of character string area
0050 to 1057 (in 0.1 mm units)
bbb: Line feed length
010 to 500 (in 0.1 mm units)
cc: Number of lines
01 to 99

rrr-----rrr: Data string to be printed (omissible)
Max. 255 digits

ss₁, ss₂, ss₃, -----, ss₂₀: Link field No. (omissible)
01 to 99 (1 to 99 can be also used.)
Up to 20 fields can be designated using commas.

Explanation

(1) Character string number

When drawing by the Data Command ({RC}), the format designated by the character string number is selected.

(2) Print origin of coordinates

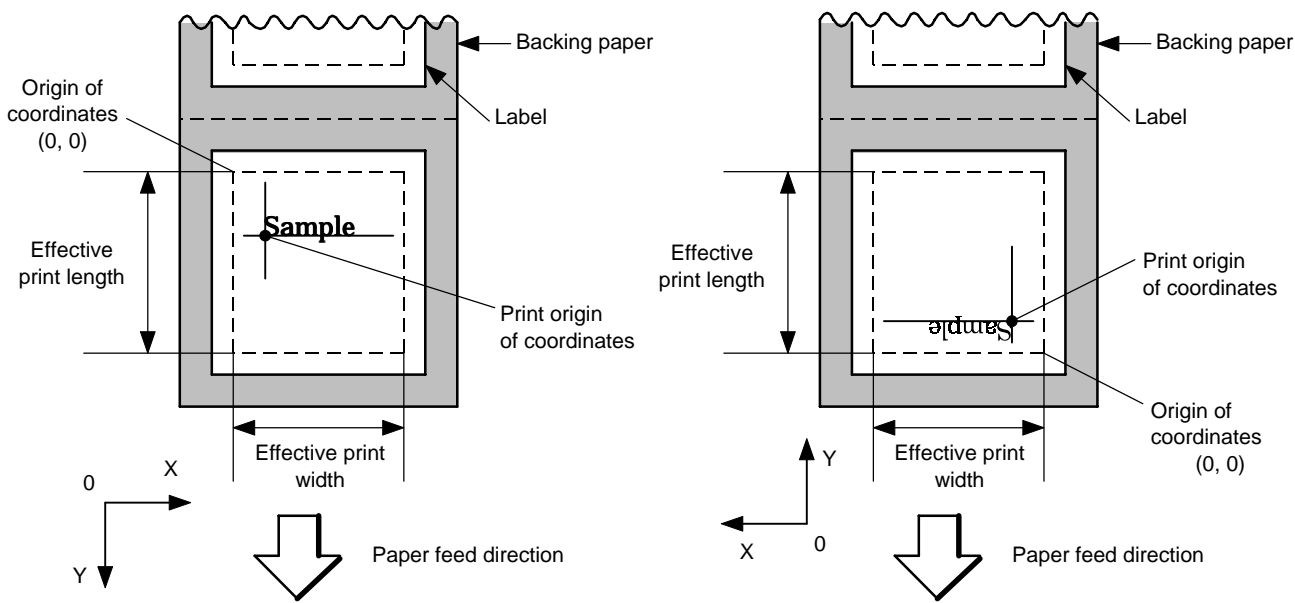

[Printing direction: Printing bottom first]

[Printing direction: Printing top first]

The print origin of coordinates must be set so that the result of character drawing will be within the effective print area set by the Label Size Set Command ({D}).

[Effective print area]

[mm]

Item	Model		B-452		
	Method		Batch	Strip	Cut
Effective print width	Min.		10.0		
	Max.		105.7		
Effective print length	Label	Min.	11.0	21.4	29.0
		Max.	500.0		
	Tag	Min.	13.0	23.4	
		Max.	500.0		

(3) Horizontal magnification and vertical magnification

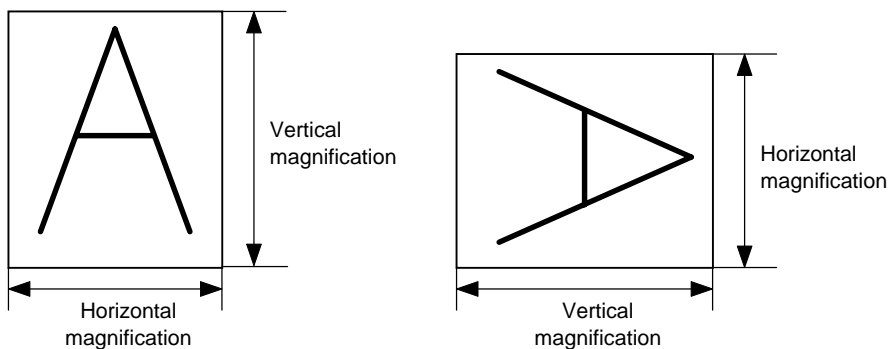

[Relationship between drawing coordinates and magnification]

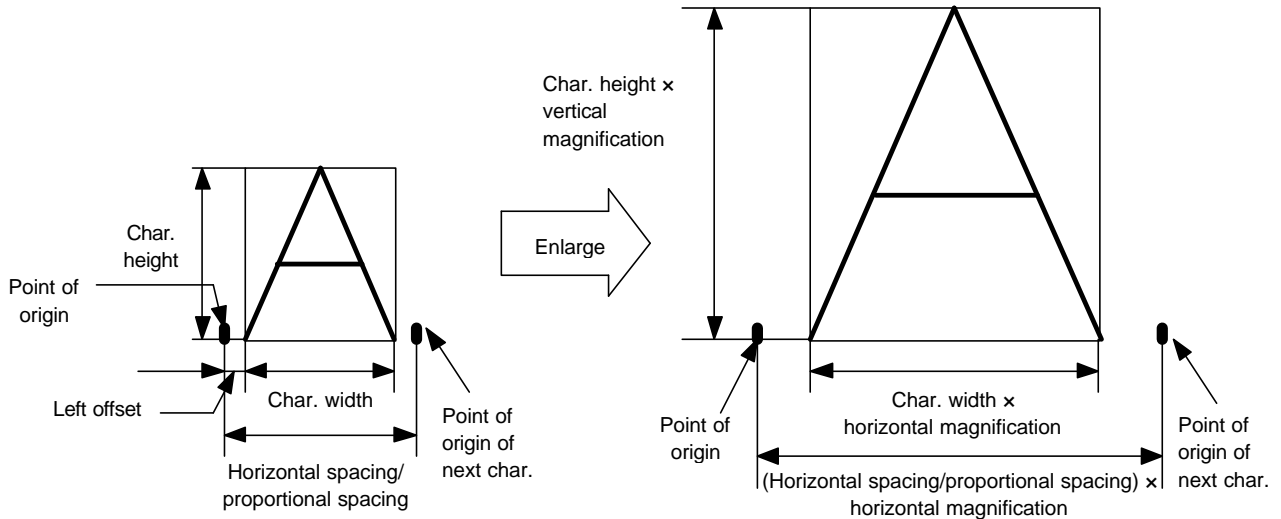

(4) Type of font

- A: Times Roman : !"#\$%&'()*+,-./0123456789:;<=>?@ABCDEFGHIJKLMN OPQRSTUVWXYZ
- B: Times Roman : !"#\$%&'()*+,-./0123456789:;<=>?@ABCDEFGHIJKLMNO PQ
- C: Times Roman : !"#\$%&'()*+,-./0123456789:;<=>?@ABCDEFGHIJKLMN OP
- D: Times Roman : !"#\$%&'()*+,-./0123456789:;<=>?@ABCDEFGHIJKL
- E: Times Roman : !"#\$%&'()*+,-./0123456789:;<=>?@ABCDEF
- F: Times Roman : !"#\$%&'()*+,-./0123456789:;<=>?@ABCDEFGHIJKL
- G: Helvetica : !"#\$%&'()*+,-./0123456789:;<=>?@ABCDEFGHIJKLMN OPQRSTUVWXYZ[]^_`abcdefghijklmnopqrstuvwxyz
- H: Helvetica : !"#\$%&'()*+,-./0123456789:;<=>?@ABCDEFGHIJKLMN OPQRS
- I: Helvetica : !"#\$%&'()*+,-./0123456789:;<=>?@ABCDEFGHIJKL
- J: Helvetica : !"#\$%&'()*+,-./0123456789:;<=>?@ABCDEFGHIJKL
- K: Helvetica : !"#\$%&'()*+,-./0123456789:;<=>?@ABCDEF
- L: Helvetica : !"#\$%&'()*+,-./0123456789:;<=>?@ABCDEFGHIJKL
- M: Presentation : **!"#\$%&'()*+,-./0123456789:**
- N: Letter Gothic : !"#\$%&'()*+,-./0123456789:;<=>?@ABCDEFGHIJKLMN OPQRSTUVWXYZ[]^_`ab
- O: Prestige Elite : !"#\$%&'()*+,-./0123456789:;<=>?@ABCDEFGHIJKLMN OPQRSTUVWXYZ[]^_`ab
- P: Prestige Elite : !"#\$%&'()*+,-./0123456789:;<=>?@ABCDEFGHIJKLMN OP
- Q: Courier : !"#\$%&'()*+,-./0123456789:;<=>?@ABCDEFGHIJKLMN OP
- R: Courier : !"#\$%&'()*+,-./0123456789:;<=>?@ABCDEFGH
- S: OCR-A : !"#\$%&'()*+,-./0123456789:;<=>?@ABCDEFGH
- T: OCR-B : !"#\$%&'()*+,-./0123456789:;<=>?@ABCDEFGH

(5) Fine adjustment of character-to-character space

If no character-to-character space is specified or the number of space dots between characters is 0, drawing will take place according to the horizontal spacing/proportional spacing determined for each character. If character-to-character space is specified, drawing will take place according to the value obtained by adding the character spacing/proportional spacing to the specified value.

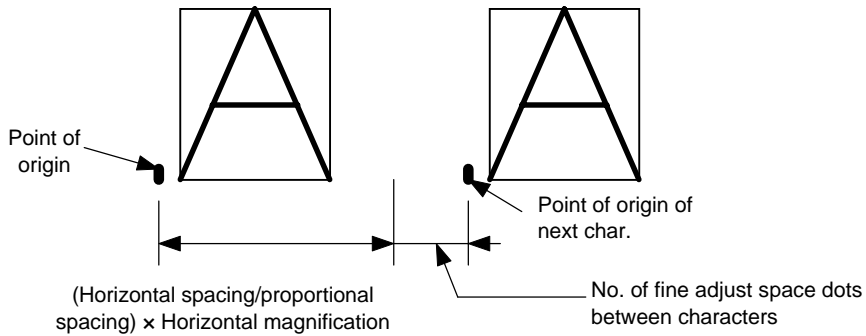

(6) Rotational angles of a character and character string

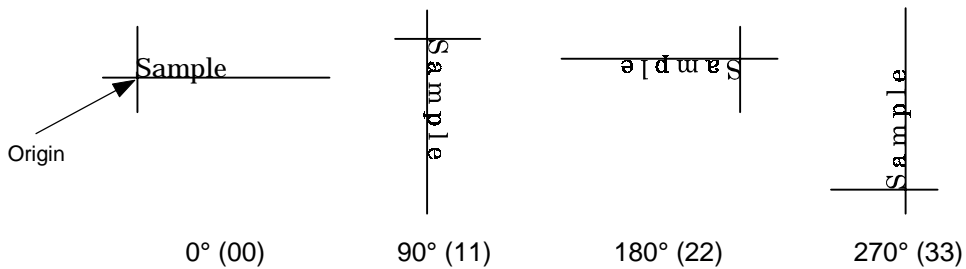

(7) Selection of character attribution

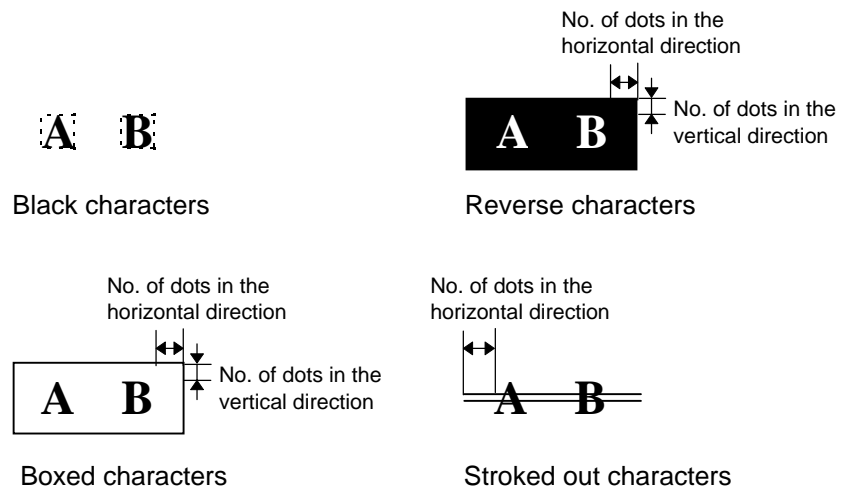

(8) Bold character designation

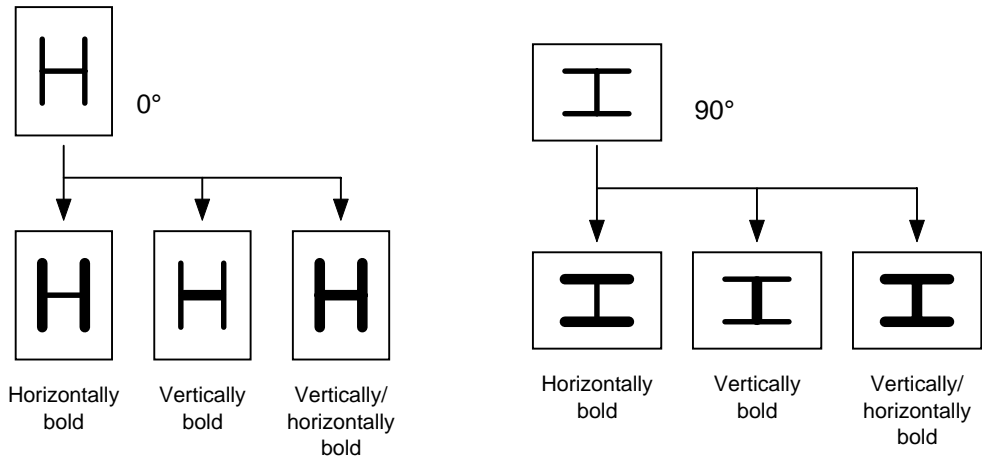

(9) Check digit to be attached

When Modulus 10 or Modulus 43 is selected, the check digit of a data row is calculated and attached to the data row for drawing. When modulus 10 is designated and the data includes any data other than the numerals, the data row will not be drawn. When modulus 43 is designated and the data includes any character other than CODE39, no drawing will take place.

When DBP Modulus 10 is selected, the check digit of a data row is calculated and only the check digit is drawn. When the data includes any data other than the numerals, drawing is not performed.

* DBP Modulus 10 is Modulus 10 for Deutsche Bundespost Postdienst only.

(10) Increment/decrement

Printing is performed while the data is incremented or decremented each time a label is issued.

Where the data row exceeds the maximum number of digits (40), the data row will not be drawn.

Initial value	0000	0000	0000	0000	999999
INC/DEC	+10	+10	+10	+10	+1
Zero suppression	Not designated	5	3	0	3
1st label	0000	0000	└000	0000	999999
2nd label	0010	0010	└010	0010	└└└000
3rd label	0020	0020	└020	0020	└└└001
4th label	0030	0030	└030	0030	└└└002
5th label	0040	0040	└040	0040	└└└003

Letters and numerals for increment/decrement

For the data string, up to 40 digits (including letters, numerals and symbols) are possible.

Example of increment/decrement calculation

Initial value	00000	A0A0A	7A8/9	A2A0A
INC/DEC	+1	+1	+3	-3
1st label	00000	A0A0A	7A8/9	A2A0A
2nd label	00001	A0A1A	7A9/2	A1A7A
3rd label	00002	A0A2A	7A9/5	A1A4A
4th label	00003	A0A3A	7A9/8	A1A1A
5th label	00004	A0A4A	8A0/1	A0A8A

(11) Zero suppression

No. of zeros to be suppressed	0	1	2	2	3	4	5
Data	0000	0000	0000	0A12	0123	0123	0123
Print	0000	▯▯▯0	▯▯00	▯A12	▯123	0123	0123

The leading zero(s) in a data row is replaced by a space(s) according to the designated number of digits. However, if the number of digits to be suppressed is greater than the data row, the data row will be drawn without zero suppression. Where the data row exceeds the maximum number of digits (40), the data row will not be drawn.

(12) Alignment

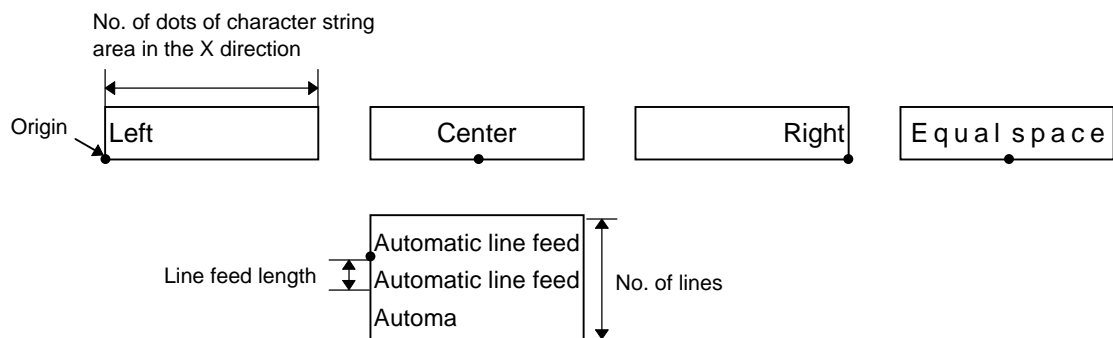

If characters are not placed on one line when equal space and automatic line feed is designated, the following step should be performed.

Decrease the value of the character-to-character space. When characters are not placed on one line if the value is set to 0, return the value to its default, and then reduce by 0.5 and 0.1 horizontal magnifications if the character horizontal magnification has been set to 1.5 or more and 1 or less, respectively.

If characters are still not placed on one line, repeatedly decrease the value of the character-to-character space, and then reduce the horizontal magnification. When characters are not placed on one line if the character magnification is set to 0.5 and the character-to-character space is set to 0, the field is not drawn. (The same previous field is not drawn.)

(13) Data string to be printed

Drawing data can be programmed by designating the number of digits after the symbol “=” Up to 255 digits can be printed. When the number of digits exceeds the maximum value, exceeding data will be discarded.

For the character code table, refer to the character code table mentioned later.

(14) Link field No.

The link field No. can be programmed by designating it after the symbol “;”. After the link field No. is designated using the Format Command, the data strings are linked by the Link Field Data Command to draw an image.

Up to 20 fields can be linked.

The following shows an example of linked fields on the two continuous labels.

[Format Command]

```
{PC01; ..... ; 01} : Link field No. 1 is designated.  
{PC02; ..... ; 03} : Link field No. 3 is designated.  
{PC03; ..... ; 04} : Link field No. 4 is designated.  
{XB01; ..... ; 03, 04} : Link fields No. 3 and No. 4 are designated.  
  
{PC04; ..... ; 02} : Link field No. 2 is designated.  
{PC05; ..... ; 03} : Link field No. 3 is designated.  
{PC06; ..... ; 04}} : Link field No. 4 is designated.  
{XB02; ..... ; 03, 04} : Link fields No. 3 and No. 4 are designated.
```

└─── Designating link field No.

[Data Command]

```
{RC; A | B | ABCD | 001}  
├─── Link field No. 1  
├─── Link field No. 2  
├─── Link field No. 3  
└─── Link field No. 4
```

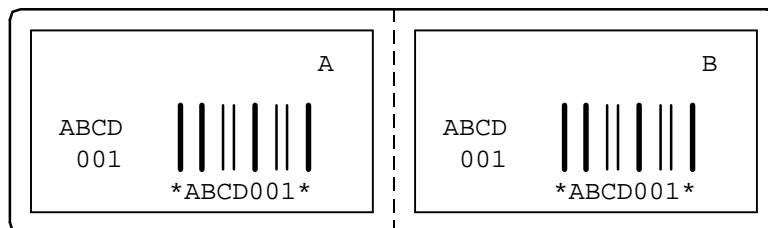

Notes

- (1) The check digit attach, increment/decrement, and zero suppress processes are performed according to the following priority. If any of the conditions is improper, no drawing will take place.

[For example, the zero(s) is replaced by a space(s) as a result of zero suppression but the modulus 10 designated to be attached cannot be calculated.]

Increment/decrement > zero suppression > attachment of check digit

- (2) Up to 32 fields for which incrementing/decrementing has been designated can be drawn. If a total of bit map font, outline font or bar code increment/decrement fields exceeds 32, drawing will take place without incrementing/decrementing any excessive field. The field to be incremented or decremented is incremented or decremented until the Image Buffer Clear Command ({C) is transmitted.

[Example]

- 1) Format Command (Increment character string No. 001 (+1))
- 2) Format Command (No incrementing for character string No. 002)
- 3) Format Command (Increment character string No. 003 (+2))
- 4) Image Buffer Clear Command
- 5) Data Command (Character string No. 001 "0001")
- 6) Data Command (Character string No. 002 "AB-")
- 7) Data Command (Character string No. 003 "0100")
- 8) Issue Command (2 labels)

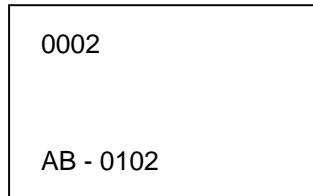
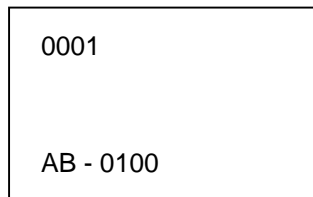

- 9) Issue Command (1 label)

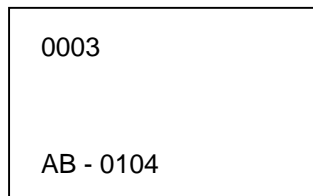

- 10) Image Buffer Clear Command
- 11) Data Command (Character string No. 002 "00000")
- 12) Issue Command (1 label)

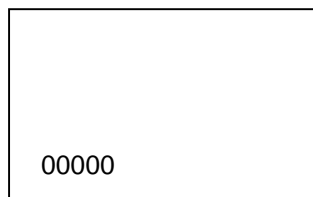

- (3) The Bit Map Font Format Command may be connected to the Outline Font Format Command when transmitted.

```
{PC001; 0100, 0150, 1, 1, A, 00, B|  
C002; 0350, 0180, 1, 1, A, 00, B|  
C005; 0200, 0300, 25, 2, C, +05, 00, B, +0000000001|  
V01; 0500, 0400, 0100, 0100, A, 00, B}}
```

- (4) When the drawing data is changed per label issue during printing, the field of the drawing data for the previous label is automatically cleared using the character string number, then the next drawing data is printed. Therefore, the character string number which differs according to the drawing fields should be designated. Since the automatic field clear is not performed between the Clear Command ({C) and Issue Command ({XS), the fixed data may be drawn using the same character string number. In this case, the Format Command and Data Command should be sent alternately. (After the Issue Command is sent, the fields with the same character string number are automatically cleared until the Clear Command is sent.)
- (5) The link field designation is cleared by omitting the link field designation using the same character string No. and reformatting data.
The link field designation can be also cleared by the Image Buffer Clear Command.
- (6) A print data string and link field No. cannot be programmed at the same time.

Refer to

Bit Map Font Data Command ({RC)
Outline Font Format Command ({PV)
Bar Code Format Command ({XB)

Examples

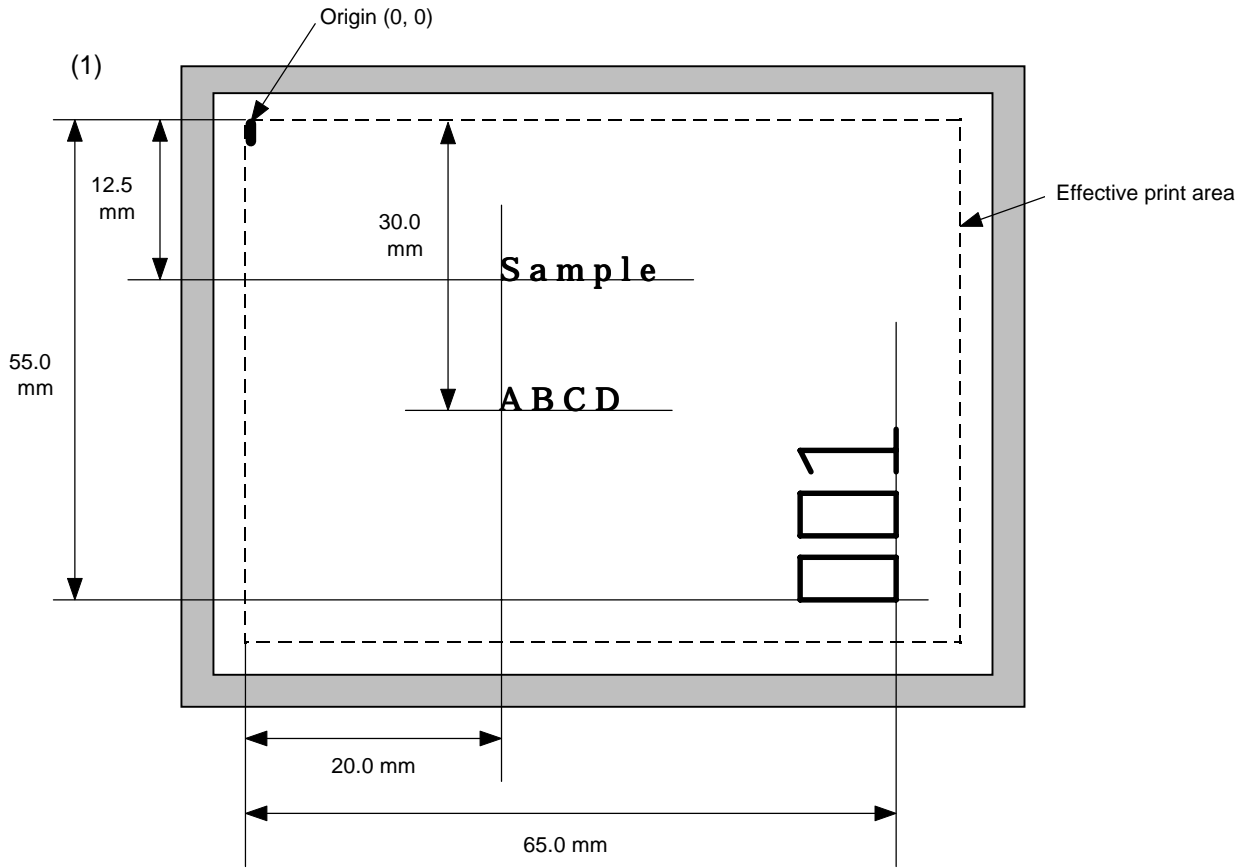

```
{C}
{PC000; 0200, 0300, 1, 1, A, 00, B=ABCD}
{PC001; 0200, 0125, 1, 1, C, 00, B}
{PC002; 0650, 0550, 2, 2, G, 33, B, +0000000001}
{RC001; Sample}
{RC002; 001}
{XS; I, 0002, 0002C2000}
```

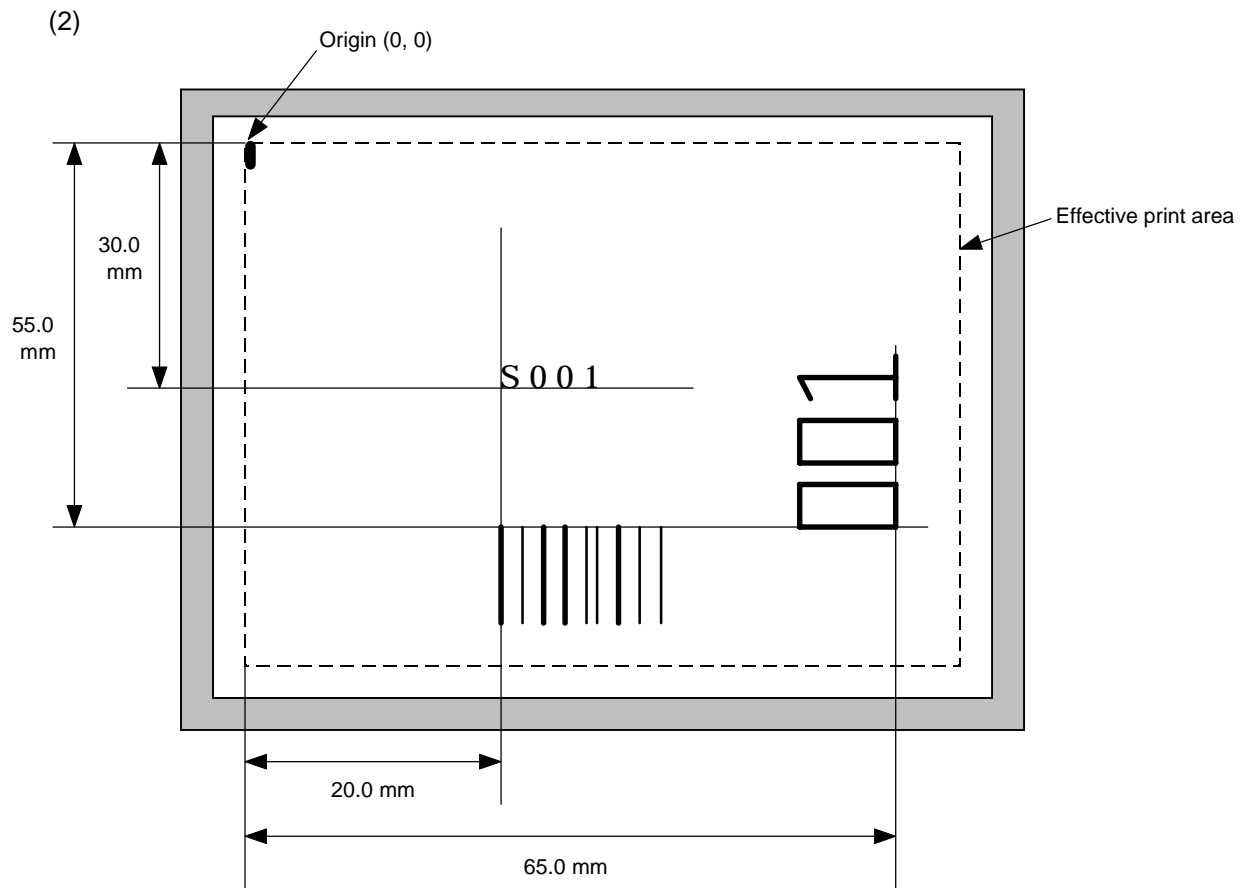

{C|}

{PC001; 0200, 0300, 1, 1, C, 00, B; 01, 02|}

{PV01; 0650, 0550, 0200, 0150, B, 33, B; 02|}

{XB01; 0200, 0550, 3, 1, 03, 03, 08, 08, 03, 0, 0150; 01, 02|}

{RC; S | 001|}

{XS; I, 0002, 0002C2000|}

6.11 OUTLINE FONT FORMAT COMMAND

{PV

Function	Sets the format to indicate the position on the label, at which the outline font is to be printed and how it is to be printed.
Format	<p>① {PVaa; bbbb, cccc, dddd, eeee, f (, ghhh), ii, j (, Mk) (, lmmmmmmmmmm) (, Znn) (, Po) (=ppp-----ppp) }</p> <p>② {PVaa; bbbb, cccc, dddd, eeee, f (, ghhh), ii, j (, Mk) (, lmmmmmmmmmm) (, Znn) (, Po) (; qq₁, qq₂, qq₃, -----, qq₂₀) }</p>
Term	<p>aa: Character string number 00 to 99</p> <p>bbbb: Print origin of X-coordinate of the character string Fixed as 4 digits (in 0.1 mm units)</p> <p>cccc: Print origin of Y-coordinate of the character string Fixed as 4 digits (in 0.1 mm units)</p> <p>dddd: Character width Font type: A, B 0020 to 0999 (in 0.1 mm units) Font type: E~I 0020 to 0999 (in 0.1 mm units) Font type: 01 to 25 0020 to 0800 (in 0.1 mm units)</p> <p>eeee: Height of the character Font type: A, B 0020 to 0999 (in 0.1 mm units) Font type: E~I 0020 to 0999 (in 0.1 mm units) Font type: 01 to 25 0020 to 0800 (in 0.1 mm units)</p> <p>f: Type of font A: TEC FONT 1 (Helvetica [bold]) B: TEC FONT 1 (Helvetica [bold] proportional) E: Price font 1 F: Price font 2 G: Price font 3 H: TEC FONT 2 I: TEC FONT 3 01 to 25: TrueType font</p>

ghhh: Fine adjustment of character-to-character space (omissible)

g: Designates whether to increase or decrease the character-to-character space.

+: Increase

-: Decrease

hhh: No. of space dots between characters
000 to 512 (in dots)

ii: Rotational angles of a character and character string

00:	0° (char.)	0° (char.-string)
11:	90° (char.)	90° (char.-string)
22:	180° (char.)	180° (char.-string)
33:	270° (char.)	270° (char.-string)

j: Character attribution

B: Black character

W (aabb): Reverse character

aa: No. of dots from the character string to the end of the black background in the horizontal direction

bb: No. of dots from the character string to the end of the black background in the vertical direction.

aa: 01 to 99 (in units of dots)

bb: 01 to 99 (in units of dots)

F (aabb): Boxed character

aa: No. of dots from the character string area to the box in the horizontal direction

bb: No. of dots from the character string area to the box in the vertical direction

aa: 01 to 99 (in units of dots)

bb: 01 to 99 (in units of dots)

C (aa): Stroked out character

aa: No. of dots from the character string area to the end of the stroke

aa: 01 to 99 (in units of dots)

* Descriptions in parentheses are omissible.
(If omitted, it is the character size ÷ 8 dots.)

Mk: Type of the check digit to be attached (omissible)

k: Type of check digit

0:	Modulus 10	(Draws data and check digit)
1:	Modulus 43	(Draws data and check digit)
2:	DBP Modulus 10	(Draws check digit only)

Immmmmmmmm: Increment and decrement (omissible)

l: Designates whether to increment or decrement.

+: Increment

-: Decrement

mmmmmmmmmm: Skip value
000000000 to 9999999999

Znn: Zero suppression (omissible)
nn: No. of zeros to be suppressed
00 to 20

Po: Alignment

o: Designates the character position.

1: Left

2: Center

3: Right

4aaaa: Equal space

aaaa: X direction of character string area
0050 to 1057 (in 0.1 mm units)

Font type: 01 to 25

Regardless of the designation, align left.

In the case of Arabic, align right. (Letters are printed from right to left.)

ppp-----ppp: Data string to be printed (omissible)
Max. 255 digits

qq₁, qq₂, qq₃, -----, qq₂₀: Link field No. (omissible)
01 to 99 (1 to 99 can be also used.)
Up to 20 fields can be designated using commas.

Explanation

(1) Character string number

When drawing by the Data Command ({RV), the format designated by the character string number is selected.

(2) Print origin of coordinates

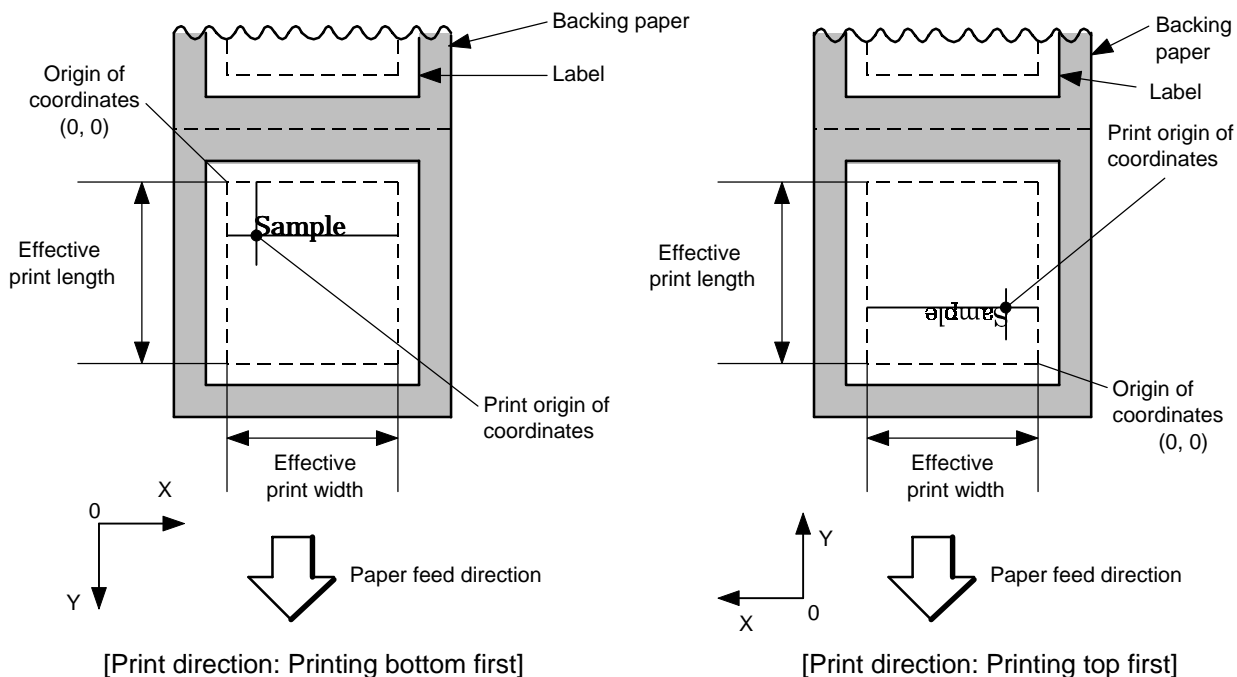

- The print origin of coordinates must be set so that the result of character drawing will be within the effective print area set by the Label Size Set Command ({D).

[Effective print area]

[mm]

Item		Model	B-452		
		Method	Batch	Strip	Cut
Effective print width		Min.	10.0		
		Max.	105.7		
Effective print length	Label	Min.	11.0	21.4	29.0
		Max.	500.0		
	Tag	Min.	13.0	23.4	
		Max.	500.0		

(3) Character width and character height

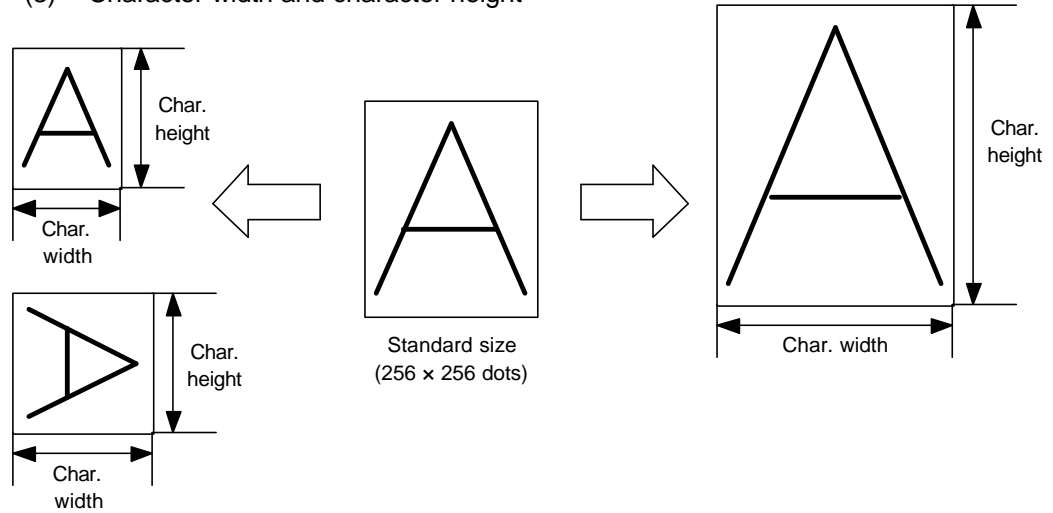

For the font type: 01 to 25

The maximum font size changes according to the font type and the character type. The maximum value for the parameter is 400, however, it is possible to specify a value up to 600. If the designated value is out of range, nothing will be printed in the area.

(4) Type of font

A: TEC FONT 1 (Helvetica [bold])

! " # \$ % & ' () * + , - . /
0 1 2 3 4 5 6 7 8 9 : ; < = > ?
@ A B C D E F G H I J K L M N O
P Q R S T U V W X Y Z [¥] ^ _
' a b c d e f g h i j k l m n o
p q r s t u v w x y z { | } ~ Δ

B: TEC FONT 1 (Helvetica [bold] proportional)

! " # \$ % & ' () * + , - . /
0 1 2 3 4 5 6 7 8 9 : ; < = > ?
@ A B C D E F G H I J K L M N O
P Q R S T U V W X Y Z [¥] ^ _
' a b c d e f g h i j k l m n o
p q r s t u v w x y z { | } ~ Δ

E: Price font 1 (POP font)

\$%, - . /
0 1 2 3 4 5 6 7 8 9
円 ¥ ~

F: Price font 2 (POP font)

\$%, - . /
0 1 2 3 4 5 6 7 8 9
円 ¥ ~

G: Price font 3 (POP font)

\$%, - . /
0 1 2 3 4 5 6 7 8 9
円 ¥ ~

H: TEC FONT 2

!"#\$%&'()*+,-./
0123456789:;<=>?
@ABCDEFGHIJKLMNO
PQRSTUVWXYZ[\]^_
`abcdefghijklmno
pqrstuvwxyz{|}~

I: TEC FONT 3

!"#\$%&'()*+,-./
0123456789:;<=>?
@ABCDEFGHIJKL MNO
PQRSTUVWXYZ[\]^_
`abcdefghijklmno
pqrstuvwxyz{|}~

01 to 25: TrueType font

Nos. 01 to 25 correspond to the TrueType fonts that the user downloads to the printer by using the TEC Ttf downloader. The TEC Ttf downloader enables the user to assign a TrueType font to any number between 01 to 25.

(5) Fine adjustment of character-to-character space

If no character-to-character space is specified or the number of space dots between characters is 0, drawing will take place according to the horizontal spacing/proportional spacing determined for each character. If character-to-character space is specified, drawing will take place according to the value obtained by adding the character spacing/proportional spacing to the specified value. When equal space is selected in the alignment, the character-to-character space setting is invalid. (The horizontal spacing/proportional spacing are increased or decreased depending on the character size.)

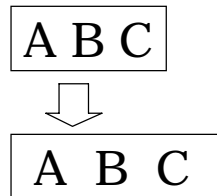

(6) Rotational angles of a character and character string

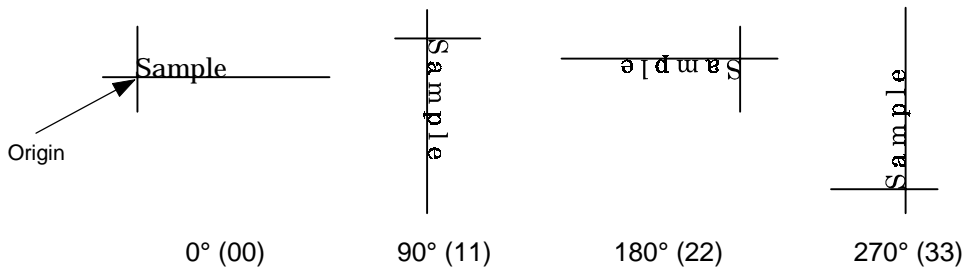

(7) Selection of character attribution

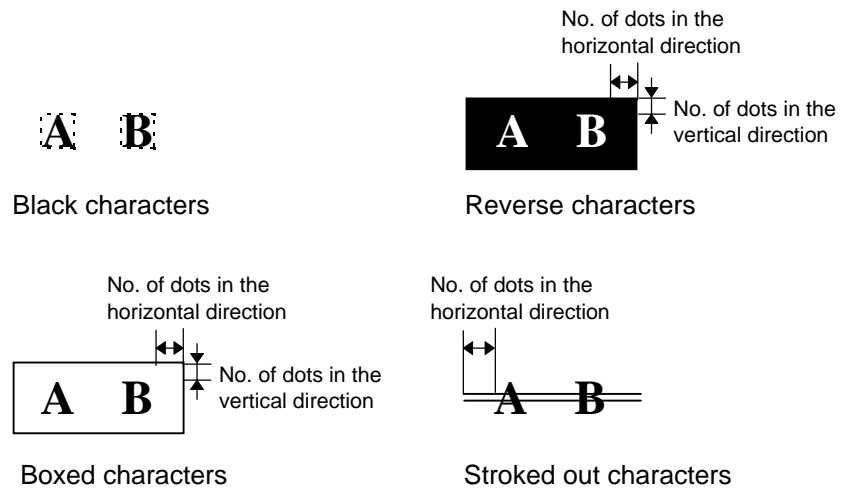

(8) Check digit to be attached

When Modulus 10 or Modulus 43 is selected, the check digit of a data row is calculated and attached to the data row for drawing. When modulus 10 is designated and the data includes any data other than the numerals, the data row will not be drawn. When modulus 43 is designated and the data includes any character other than CODE39, no drawing will take place.

When DBP Modulus 10 is selected, the check digit of a data row is calculated and only the check digit is drawn. When the data includes any data other than the numerals, drawing is not performed.

* DBP Modulus 10 is Modulus 10 for Deutsche Bundespost Postdienst only.

(9) Increment/decrement

Printing is performed while the data is incremented or decremented each time a label is issued.

Where the data row exceeds the maximum number of digits (40), the data row will not be drawn.

Initial value	0000	0000	0000	0000	999999
INC/DEC	+10	+10	+10	+10	+1
Zero suppression	Not designated	5	3	0	3
1st label	0000	0000	└000	0000	999999
2nd label	0010	0010	└010	0010	└└└000
3rd label	0020	0020	└020	0020	└└└001
4th label	0030	0030	└030	0030	└└└002
5th label	0040	0040	└040	0040	└└└003

Letters and numerals for increment/decrement

For the data string, up to 40 digits (including letters, numerals and symbols) are possible.

Example of increment/decrement calculation

Initial value	00000	A0A0A	7A8/9	A2A0A
INC/DEC	+1	+1	+3	-3
1st label	00000	A0A0A	7A8/9	A2A0A
2nd label	00001	A0A1A	7A9/2	A1A7A
3rd label	00002	A0A2A	7A9/5	A1A4A
4th label	00003	A0A3A	7A9/8	A1A1A
5th label	00004	A0A4A	8A0/1	A0A8A

(10) Zero suppression

No. of zeros to be suppressed	0	1	2	2	3	4	5
Data	0000	0000	0000	0A12	0123	0123	0123
Print	0000	0	00	A12	123	0123	0123

The leading zero(s) in a data row is replaced by a space(s) according to the designated number of digits. However, if the number of digits to be suppressed is greater than the data row, the data row will be drawn without zero suppression. Where the data row exceeds the maximum number of digits (40), the data row will not be drawn.

(11) Alignment



If characters are not placed on one line when equal space is designated, the width is calculated automatically. When the width is less than the limit value (2 mm) for the outline font, the field is not drawn. (The same previous field is also not drawn.)

(12) Data string to be printed

Drawing data can be programmed by designating the number of digits after the symbol “=”. Up to 255 digits can be printed. When the number of digits exceeds the maximum value, any excessive data will be discarded.

For the character code table, refer to the character code table mentioned later.

(13) Link field No.

The link field No. can be programmed by designating it after the symbol “;”. After the link field No. is designated using the Format Command, the data strings are linked by the Link Field Data Command to draw an image.

Up to 20 fields can be linked.

The following shows an example of linked fields on two continuous labels.

[Format Command]

- {PV01; ; 01} : Link field No. 1 is designated.
- {PV02; ; 03} : Link field No. 3 is designated.
- {PV03; ; 04} : Link field No. 4 is designated.
- {XB01; ; 03, 04} : Link fields No. 3 and No. 4 are designated.

- {PV04; ; 02} : Link field No. 2 is designated.
- {PV05; ; 03} : Link field No. 3 is designated.
- {PV06; ; 04} : Link field No. 4 is designated.
- {XB02; ; 03, 04} : Link fields No. 3 and No. 4 are designated.

└── Designating link field No.

[Data Command]

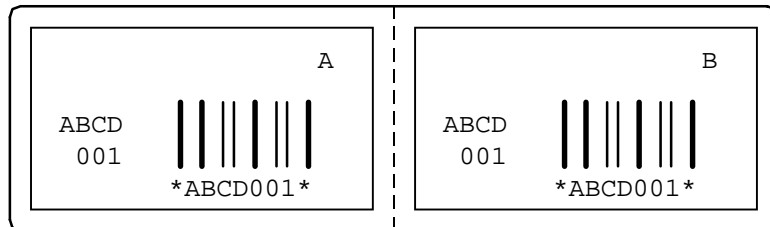
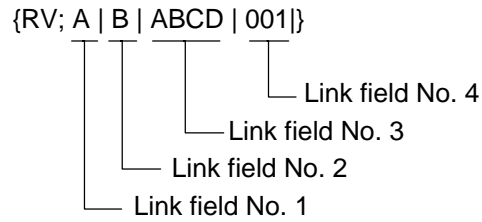

Notes

- (1) The check digit attach, increment/decrement, and zero suppress processes are performed according to the following priority. If any of the conditions is improper, no drawing will take place.

For example, the zero(s) is replaced by a space(s) as a result of zero suppression, but the modulus 10 designated to be attached cannot be calculated.

Increment/decrement > zero suppression > attachment of check digit

- (2) Up to 32 fields for which incrementing/decrementing has been designated can be drawn. If a total of bit map font, outline font, or bar code increment/decrement fields exceeds 32, drawing will take place without incrementing/decrementing any excessive field. The field to be incremented or decremented is incremented or decremented until the Image Buffer Clear Command ({C) is transmitted.

[Examples]

- 1) Format Command (Increment character string No. 01 (+1))
- 2) Format Command (No incrementing for character No. 02)
- 3) Format Command (Increment character string No. 03 (+2))
- 4) Image Buffer Clear Command
- 5) Data Command (Character string No. 01 "0001")
- 6) Data Command (Character string No. 02 "AB-")
- 7) Data Command (Character string No. 03 "0100")
- 8) Issue Command (2 labels)

0001
AB-0100

0002
AB-0102

- 9) Issue Command (1 label)

0003
AB-0104

- 10) Image Buffer Clear Command
- 11) Data Command (Character string No. 02 "00000")
- 12) Issue Command (1 label)

00000

- (3) The Outline Font Format Command may be connected to the Bit Map Font Format Command when transmitted.

```
{PC001; 0100, 0150, 1, 1, A, 00, B|
C002; 0350, 0180, 1, 1, A, 00, B|
C005; 0200, 0300, 25, 2, C, +05, 00, B, +0000000001|
V01; 0500, 0400, 0100, 0100, A, 00, B}
```

- (4) When the drawing data is changed per label issue during printing, the field of the drawing data for the previous label is automatically cleared using the character string number, then the next drawing data is printed. Therefore, the character string number which differs according to the drawing fields should be designated. Since the automatic field clear is not performed between the Clear Command ({C) and Issue Command ({XS), the fixed data may be drawn using the same character string number. In this case, the Format Command and Data Command should be sent alternately. (After the Issue Command is sent, the fields with the same character string number are automatically cleared until the Clear Command is sent.)
- (5) When characters overlap due to the character-to-character space fine adjustment, the outline font is not painted properly. Program the fine adjust value so that characters will not overlap. Also, when drawings such as lines or characters are on the outline font drawing position, the outline font is not painted properly. When font type A or B is used, program the fine adjust value so that drawings will not overlap in the outline font drawing area.
- (6) The link field designation is cleared by omitting the link field designation using the same character string No. and reformatting data.
The link field designation can be also cleared by the Image Buffer Clear Command.
- (7) A print data string and link field No. cannot be programmed at the same time.

Refer to

Outline Font Data Command ({RV)
Bit Map Font Format Command ({PC)
Bar Code Format Command ({XB)

Examples

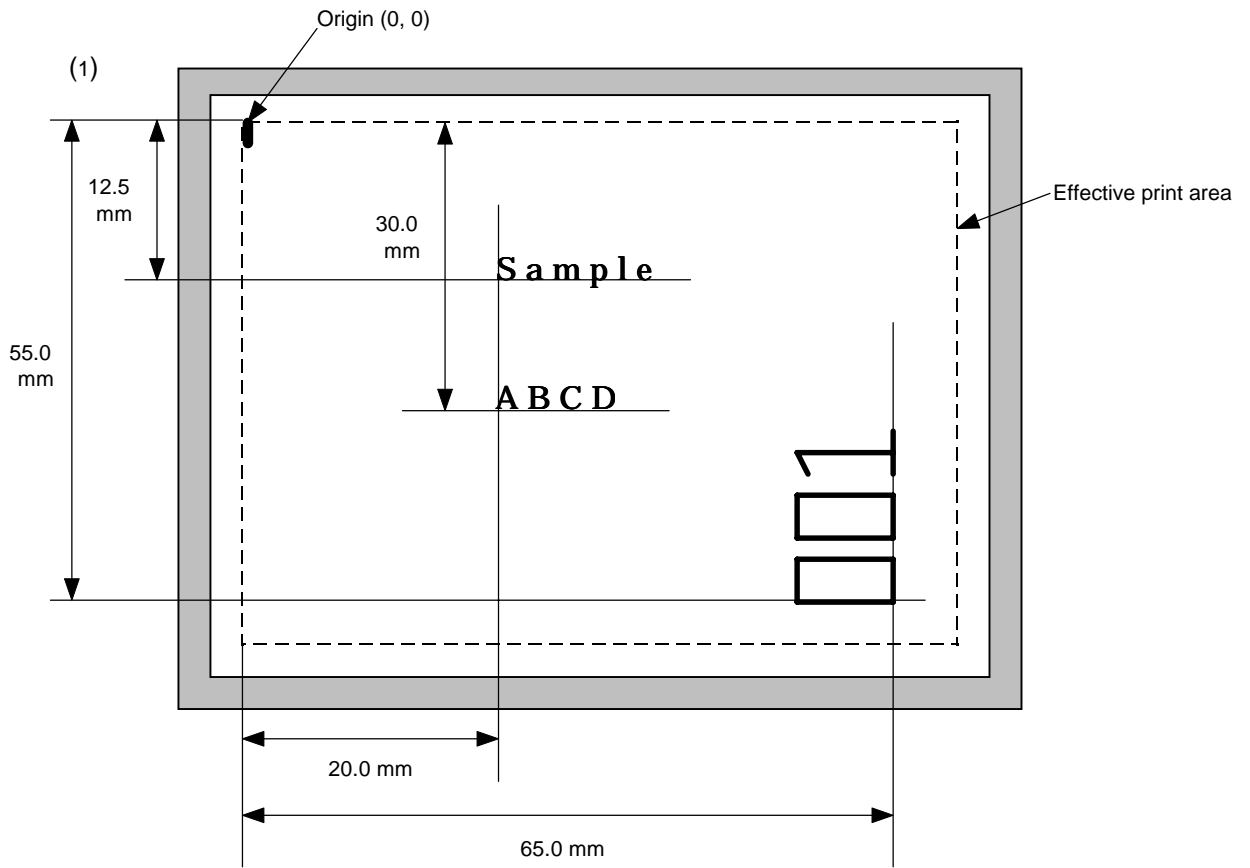

```

{C}
{PV00; 0200, 0300, 0080, 0080, B, 00, B=ABCD}
{PV01; 0200, 0125, 0100, 0100, B, 00, B}
{PV02; 0650, 0550, 0200, 0150, B, 33, B, +0000000001}
{RV01; Sample}
{RV02; 001}
{XS; I, 0002, 0002C2000}
    
```

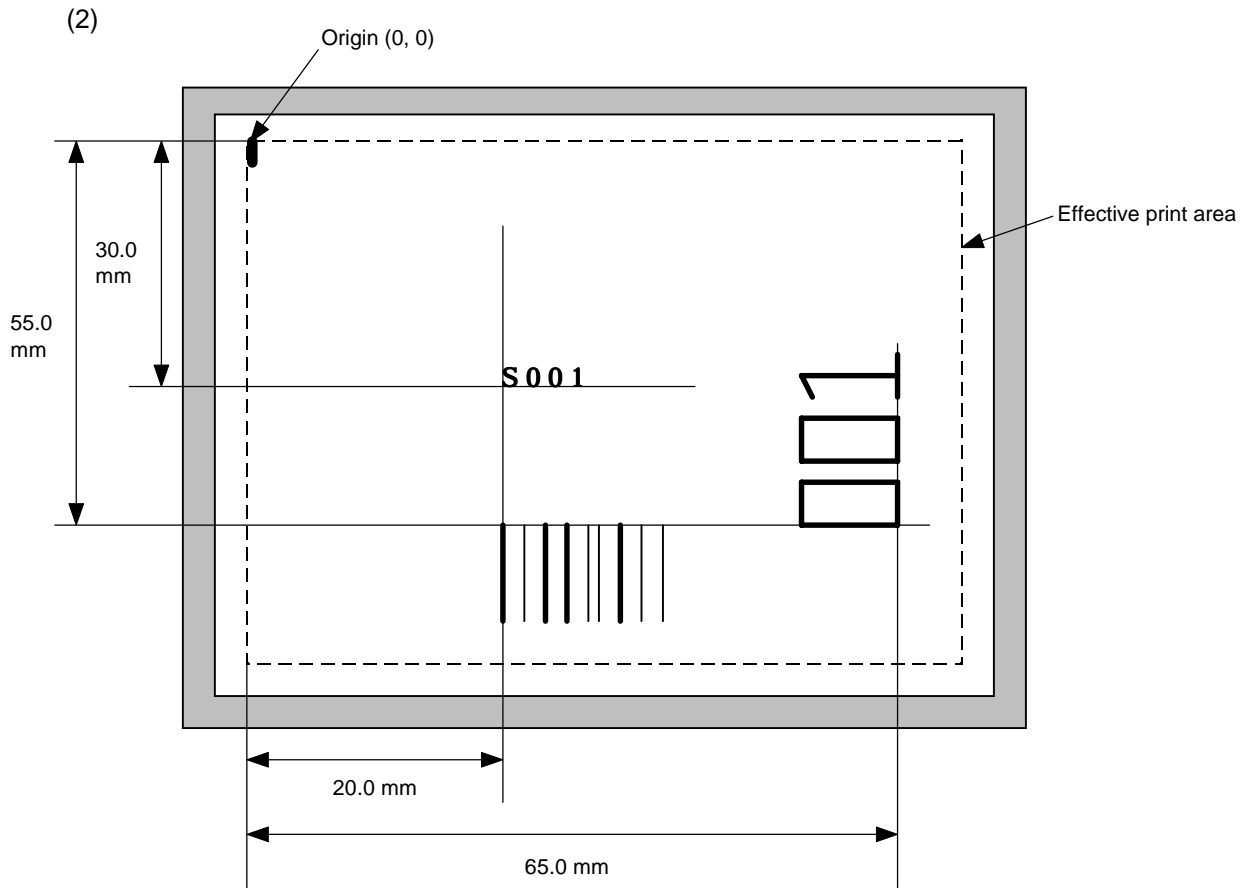

```

{C}
{PC001; 0200, 0300, 1, 1, C, 00, B; 01, 02}
{PV01; 0650, 0550, 0200, 0150, B, 33, B; 02}
{XB01; 0200, 0550, 3, 1, 03, 03, 08, 08, 03, 0, 0150; 01, 02}
{RV; S | 001}
{XS; I, 0002, 0002C2000}
  
```

6.12 BAR CODE FORMAT COMMAND

{XB

Function	Sets the format to indicate the position on the label, at which the bar code is to be printed and how it is to be printed.
----------	--

⊙ In the case of WPC, CODE93, CODE128, UCC/EAN128 and various postal codes

Format	① {XBaa; bbbb, cccc, d, e, ff, k, llll (, mnnnnnnnnnn, ooo, p, qq) (= sss ----- sss) } ② {XBaa; bbbb, cccc, d, e, ff, k, llll (, mnnnnnnnnnn, ooo, p, qq) (; tt ₁ , tt ₂ , tt ₃ , -----, tt ₂₀) }
--------	---

Term	aa: Bar code number 00 to 31 bbbb: Print origin of X-coordinate of the bar code Fixed as 4 digits (in 0.1 mm units) cccc: Print origin of Y-coordinate of the bar code Fixed as 4 digits (in 0.1 mm units) d: Type of bar code 0: JAN8, EAN8 5: JAN13, EAN13 6: UPC-E 7: EAN13 + 2 digits 8: EAN13 + 5 digits 9: CODE128 (with auto code selection) A: CODE128 (without auto code selection) C: CODE93 G: UPC-E + 2 digits H: UPC-E + 5 digits I: EAN8 + 2 digits J: EAN8 + 5 digits K: UPC-A L: UPC-A + 2 digits M: UPC-A + 5 digits N: UCC/EAN128 R: Customer bar code (for Japan) S: Highest priority customer bar code (for Japan) U: POSTNET (for U.S) V: RM4SCC (ROYAL MAIL 4 STATE CUSTOMER CODE) (for U.K) W: KIX CODE (for Belgium)
------	---

- e: Type of check digit
- 1: Without attaching check digit
 - 2: Check digit check
 - WPC Modulus 10
 - CODE93 Modulus 47
 - CODE128 PSEUDO 103
 - 3: Check digit auto attachment (1)
 - WPC Modulus 10
 - CODE93 Modulus 47
 - CODE128 PSEUDO 103
 - UCC/EAN128 Modulus 10 + Modulus 103
 - Customer code Special check digit
 - POSTNET Special check digit
 - RM4SCC Special check digit
 - 4: Check digit auto attachment (2)
 - WPC Modulus 10 + Price C/D 4 digits
 - 5: Check digit auto attachment (3)
 - WPC Modulus 10 + Price C/D 5 digits
- (NOTE: For postal codes, only "3: Check digit auto attachment (1)" is available.)**
- ff: 1-module width
01 to 15 (in dots)
- k: Rotational angle of bar code
- 0: 0°
 - 1: 90°
 - 2: 180°
 - 3: 270°
- lll: Height of the bar code
0000 to 1000 (in 0.1 mm units)
(For postal codes, a long bar length should be designated.)
- mnnnnnnnn: Increment/decrement (omissible)
- m: Indicates whether to increment or decrement
 - +: Increment
 - : Decrement
 - nnnnnnnn: Skip value
0000000000 to 9999999999
- ooo: Length of the WPC guard bar (omissible)
000 to 100 (in 0.1 mm units)
- p: Selection of print or non-print of numerals under bars (omissible)
- 0: Non-print
 - 1: Print
- qq: No. of zeros to be suppressed (omissible)
00 to 20
- sss ----- sss: Data string to be printed (omissible)
Max. 126 digits. However, it varies according to the type of bar code.
- tt₁, tt₂, tt₃, -----, tt₂₀: Link field No. (omissible)
01 to 99 (1 to 99 can be also used.)
Up to 20 fields can be designated using commas.
- * Omissible parameters cannot be set when the postal code (Type of bar code: R, S, U, V, or W) is used.

⊙ In the case of MSI, Interleaved 2 of 5, CODE39, NW7, and Industrial 2 of 5

Format	
①	{XBaa; bbbb, cccc, d, e, ff, gg, hh, ii, jj, k, llll (, mnnnnnnnnnn, p, qq) (, r) (=sss-----sss) }
②	{XBaa; bbbb, cccc, d, e, ff, gg, hh, ii, jj, k, llll (, mnnnnnnnnnn, p, qq) (, r) (; tt ₁ , tt ₂ , tt ₃ , -----, tt ₂₀) }

Term	
aa:	Bar code number 00 to 31
bbbb:	Print origin of X-coordinate of the bar code Fixed as 4 digits (in 0.1 mm units)
cccc:	Print origin of Y-coordinate of the bar code Fixed as 4 digits (in 0.1 mm units)
d:	Type of bar code 1: MSI 2: Interleaved 2 of 5 3: CODE39 (standard) 4: NW7 B: CODE39 (full ASCII) O: Industrial 2 of 5
e:	Type of check digit 1: Without attaching check digit 2: Check digit check CODE39 Modulus 43 MSI IBM modulus 10 ITF Modulus 10 Industrial 2 of 5 Modulus check character 3: Check digit auto attachment (1) CODE39 Modulus 43 MSI IBM modulus 10 ITF Modulus 10 Industrial 2 of 5 Modulus check character 4: Check digit auto attachment (2) MSI IBM modulus 10 + IBM modulus 10 ITF DBP Modulus 10 5: Check digit auto attachment (3) MSI IBM modulus 11 + IBM modulus 10
ff:	Narrow bar width 01 to 99 (in dots)
gg:	Narrow space width 01 to 99 (in dots) * In the case of Industrial 2 of 5, an element-to-element space is designated.
hh:	Wide bar width 01 to 99 (in dots)

- ii: Wide space width
01 to 99 (in dots)
* In the case of Industrial 2 of 5, the value is fixed to 00.
- jj: Character-to-character space width
01 to 99 (in dots)
* In the case of MSI and ITF, character-to-character space width is set to 00.
- k: Rotational angle of bar code
0: 0°
1: 90°
2: 180°
3: 270°
- lll: Height of the bar code
0000 to 1000 (in 0.1 mm units)
- nnnnnnnnnn: Increment/decrement (omissible)
 - m: Indicates whether to increment or decrement
 - +: Increment
 - : Decrement
 - nnnnnnnnnn: Skip value
0000000000 to 9999999999
- p: Selection of print or non-print of numerals under bars
0: Non-print
1: Print
- qq: No. of zeros to be suppressed (omissible)
00 to 20
- r: Designates the attachment of start/stop code (omissible)
 - T: Attachment of start code only
 - P: Attachment of stop code only
 - N: Start/stop code unattached
- sss-----sss: Data string to be printed (omissible)
Max. 126 digits. However, the number of digits varies according to the type of bar code.
- tt₁, tt₂, tt₃, -----, tt₂₀: Link field No. (omissible)
01 to 99 (1 to 99 can be also used.)
Up to 20 fields can be designated using commas.

⊙ In the case of Data Matrix (two-dimensional code)

Format	<p>① {XBaa; bbbb, cccc, d, ee, ff, gg, h (, Ciiijj) (, Jkklmmnn) (= ooo ----- ooo) }</p> <p>② {XBaa; bbbb, cccc, d, ee, ff, gg, h (, Ciiijj) (, Jkklmmnn) (= pp₁, pp₂, pp₃, -----, pp₂₀) }</p>
--------	--

Term	<p>aa: Bar code number 00 to 31</p> <p>bbbb: Print origin of X-coordinate of the bar code Fixed as 4 digits (in 0.1 mm units)</p> <p>cccc: Print origin of Y-coordinate of the bar code Fixed as 4 digits (in 0.1 mm units)</p> <p>d: Type of bar code Q: Data Matrix (two-dimensional code)</p> <p>ee: ECC type 00: ECC0 01: ECC50 04: ECC50 05: ECC80 06: ECC80 07: ECC80 08: ECC80 09: ECC100 10: ECC100 11: ECC140 12: ECC140 13: ECC140 14: ECC140 20: ECC200</p> <p>ff: 1-cell width 00 to 99 (in dots)</p> <p>gg: Format ID 01: Format ID 1 02: Format ID 2 03: Format ID 3 04: Format ID 4 05: Format ID 5 06: Format ID 6</p>
------	--

* When ECC200 is designated as ECC type, the format ID designation is ignored.

h: Rotational angle of bar code

- 0: 0°
- 1: 90°
- 2: 180°
- 3: 270°

Ciiijj: No. of cells (When this parameter is omitted, it is automatically set.)

- iii: No. of cells in the X direction 000 to 144
- jjj: No. of cells in the Y direction 000 to 144

* Cell setting varies according to the ECC type.

	ECC0 to ECC140	ECC200
No. of cells to be designated	Odd numbers only	Even numbers only
Min./Max. No. of cells	9×9 to 49×49	10×10 to 144×144
Rectangular code	None	18×8 32×8 26×12 36×12 36×16 48×16

- When this parameter is omitted, the number of cells is automatically set. Also, when data except for the above values is designated in the X and Y directions, the number of cells is automatically set.

Jkklmmnnn: Connection setting (No connection when this parameter is omitted.)
It is valid when ECC200 is selected.

- kk: Code number 01 to 16
- ll: No. of divided codes 01 to 16
- mmm: ID number 1 001 to 254
- nnn: ID number 2 001 to 254

ooo ----- ooo: Data string to be printed (omissible)
Max. 2000 digits.

pp₁, pp₂, pp₃, -----, pp₂₀: Link field No. (omissible)
01 to 99 (1 to 99 can also be used.)
Up to 20 fields can be designated using commas.

⊙ In the case of PDF417 (two-dimensional code)

Format	
	① {XBaa; bbbb, cccc, d, ee, ff, gg, h, iii (=jjj-----jjj) }
	② {XBaa; bbbb, cccc, d, ee, ff, gg, h, iii (; kk ₁ , kk ₂ , kk ₃ , -----, kk ₂₀) }
Term	
aa:	Bar code number 00 to 31
bbbb:	Print origin of X-coordinate of the bar code Fixed as 4 digits (in 0.1 mm units)
cccc:	Print origin of Y-coordinate of the bar code Fixed as 4 digits (in 0.1 mm units)
d:	Type of bar code P: PDF417 (two-dimensional code)
ee:	Security level 00: Level 0 01: Level 1 02: Level 2 03: Level 3 04: Level 4 05: Level 5 06: Level 6 07: Level 7 08: Level 8
ff:	1-module width 01 to 10 (in dots)
gg:	No. of columns (strings) 01 to 30
h:	Rotational angle of bar code 0: 0° 1: 90° 2: 180° 3: 270°
iiii:	Bar height 0000 to 0100 (in 0.1 mm units)
jjj-----jjj:	Data string to be printed (omissible) Max. 2,000 digits
kk ₁ , kk ₂ , kk ₃ , -----, kk ₂₀ :	Link field No. (omissible) 01 to 99 (1 to 99 can be also used.) Up to 20 fields can be designated using commas.

⊙ In the case of QR code (two-dimensional code)

Format	① {XBaa; bbbb, cccc, d, e, ff, g, h (, Mi) (, Kj) (, Jkklmm) (= nnn --- nnn) }
	② {XBaa; bbbb, cccc, d, e, ff, g, h (, Mi) (, Kj) (, Jkklmm) (= oo ₁ , oo ₂ , oo ₃ ----- oo ₂₀) }
Term	<p>aa: Bar code number 00 to 31</p> <p>bbbb: Print origin of X-coordinate of the bar code Fixed as 4 digits (in 0.1 mm units)</p> <p>cccc: Print origin of Y-coordinate of the bar code Fixed as 4 digits (in 0.1 mm units)</p> <p>d: Type of bar code T: QR code (two-dimensional code)</p> <p>e: Designation of error correction level L: High density level M: Standard level Q: Reliability level H: High reliability level</p> <p>ff: 1-cell width 00 to 52 (in dots)</p> <p>g: Selection of mode M: Manual mode A: Automatic mode</p> <p>h: Rotational angle of the bar code 0: 0° 1: 90° 2: 180° 3: 270°</p> <p>Mi: Selection of model (When this parameter is omitted, Model 1 is automatically selected.) i =1: Model 1 2: Model 2</p> <p>Kj: Mask number (When this parameter is omitted, the number is automatically set.) j =0 to 7: Mask number 0 to 7 8: No mask</p> <p>Jkklmm: Connection setting (No connection when this parameter is omitted.) kk = 01 to 16: Value indicating which divided code is connected. ll = 01 to 16: Number of divided codes mm = 00 to FF: EX-ORed value for all data to be printed (not divided) in units of bytes</p> <p>nnn --- nnn: Data string to be printed (omissible) Max. 2000 digits</p> <p>oo₁ --- oo₂₀: Link field No. (omissible) 01 to 99 (1 to 99 can also be used.) Up to 20 digits can be designated using commas.</p>

⊙ In the case of MaxiCode (two-dimensional code)

Format

① {XBaa; bbbb, cccc, d (, e) (, Jffgg) (, Zh) }

Term

aa: Bar code number
00 to 31

bbbb: Print origin of X-coordinate of the bar code
Fixed as 4 digits (in 0.1 mm units)

cccc: Print origin of Y-coordinate of the bar code
Fixed as 4 digits (in 0.1 mm units)

d: Type of bar code
Z: MaxiCode (two-dimensional code)

e: Mode selection (omissible)
0 to 9

* However, only modes 2, 3, 4 and 6 are supported.

(When a mode other than the above is designated, the designation is corrected according to the below table.

Mode	Mode actually processed
Omitted	Mode 2
Mode 0	Mode 2
Mode 1	Mode 4
Mode 2	Mode 2
Mode 3	Mode 3
Mode 4	Mode 4
Mode 5	Mode 2
Mode 6	Mode 6
Mode 7	Mode 2
Mode 8	Mode 2
Mode 9	Mode 2

Jffgg: Connection setting

ff: Code number 01 to 08

gg: No. of divided codes 01 to 08

Zh: Attachment of Zipper block and Contrast block

0: No attachment of Zipper block and Contrast block

1: Attachment of Zipper block and Contrast block

2: Attachment of Zipper block

3: Attachment of Contrast block

⊙ In the case of MicroPDF417 (two-dimensional code)

Format	<p>① {XBaa; bbbb, cccc, d, ee, ff, gg, h, iiiii (= jjj-----jjj) }</p> <p>② {XBaa; bbbb, cccc, d, ee, ff, gg, h, iiiii (; kk₁, kk₂, kk₃, -----, kk₂₀) }</p>
Term	<p>aa: Bar code number 00 to 31</p> <p>bbbb: Print origin of X-coordinate of the bar code Fixed as 4 digits (in 0.1 mm units)</p> <p>cccc: Print origin of Y-coordinate of the bar code Fixed as 4 digits (in 0.1 mm units)</p> <p>d: Type of bar code X: MicroPDF417 (two-dimensional code)</p> <p>ee: Security level 00: Fixed</p> <p>ff: 1-module width 01 to 10 (in dots)</p> <p>gg: No. of columns/rows 00 to 38</p> <p>h: Rotational angle of bar code 0: 0° 1: 90° 2: 180° 3: 270°</p> <p>iiii: Bar height 0000 to 0100 (in 0.1 mm units)</p> <p>jjj-----jjj: Data string to be printed (Omissible) Max. 366 digits</p> <p>kk₁, kk₂, kk₃, -----, kk₂₀: Link field No. (Omissible) 01 to 99 (1 to 99 can also be used.) Up to 20 fields can be designated using commas.</p>

The maximum numbers of columns and rows for the MicroPDF417

Parameter (gg)	No. of columns	No. of rows	Max. number of digits for binary mode	Max. number of digits for upper case letter/space mode	Max. number of digits for numeric mode
00	–	–	150	250	366
01	1	–	22	38	55
02	2	–	43	72	105
03	3	–	97	162	237
04	4	–	150	250	366
05	1	11	3	6	8
06		14	7	12	17
07		17	10	18	26
08		20	13	22	32
09		24	18	30	44
10		28	22	38	55
11	2	8	8	14	20
12		11	14	24	35
13		14	21	36	52
14		17	27	46	67
15		20	33	56	82
16		23	38	64	93
17		26	43	72	105
18	3	6	6	10	14
19		8	10	18	26
20		10	15	26	38
21		12	20	34	49
22		15	27	46	67
23		20	39	66	96
24		26	54	90	132
25		32	68	114	167
26		38	82	138	202
27		44	97	162	237
28	4	4	8	14	20
29		6	13	22	32
30		8	20	34	49
31		10	27	46	67
32		12	34	58	85
33		15	45	76	111
34		20	63	106	155
35		26	85	142	208
36		32	106	178	261
37		38	128	214	313
38		44	150	250	366

“–” for parameter 00 to 04 indicates that the numbers of columns/rows are automatically set by the printer. In this case, the pattern which has a smaller number of code words is automatically selected. When the numbers of code words are equal, the pattern which has a smaller number of columns is selected.

Explanation

(1) Bar code number

When drawing by the Data Command ({RB), the format designated by the bar code is selected.

(2) Print origin of coordinates

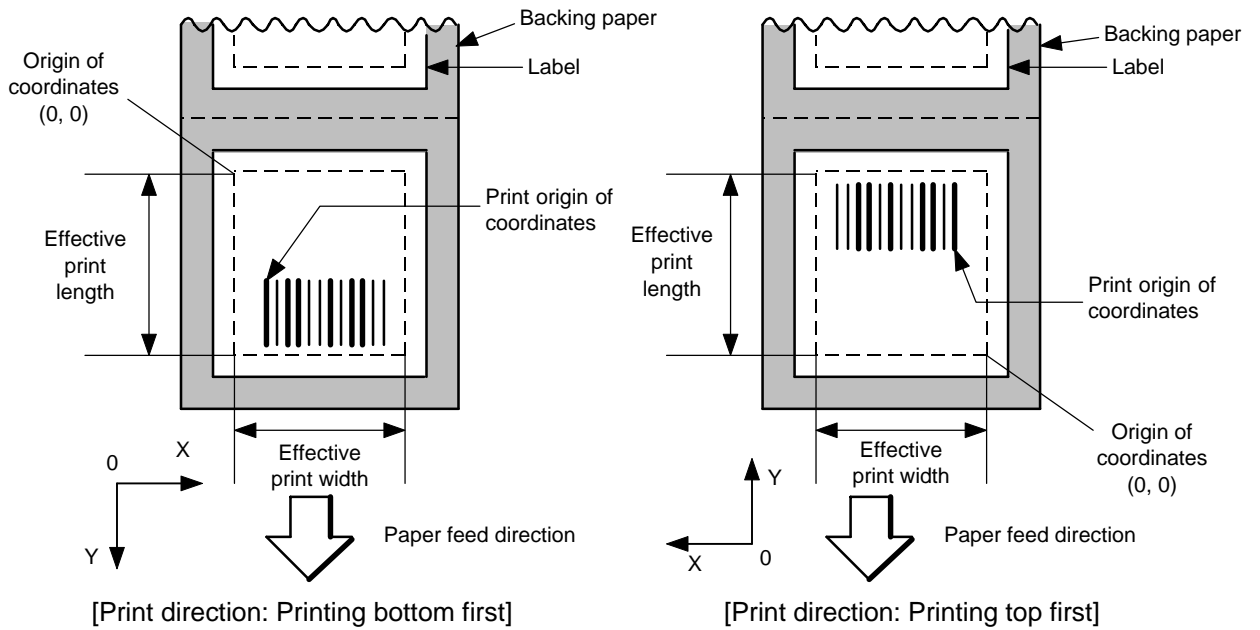

The print origin of coordinates must be set so that the result of bar code drawing will be within the effective print area set by the Label Size Set Command ({D).

[Effective print area]

[mm]

Item	Model		B-452		
	Method	Batch	Strip	Cut	
Effective print width	Min.	10.0			
	Max.	105.7			
Effective print length	Label	Min.	11.0	21.4	29.0
		Max.	500.0		
	Tag	Min.	13.0	23.4	
		Max.	500.0		

(3) Type of bar code

0: JAN8, EAN8



1: MSI



2: Interleaved 2 of 5



3: CODE39 (standard)



4: NW7



5: JAN13, EAN13



6: UPC-E



7: EAN13 + 2 digits



8: EAN13 +5 digits



9: A: CODE128



B: CODE39 (Full ASCII)



C: CODE93



G: UPC-E + 2 digits



H: UPC-E + 5 digits



I: EAN8 + 2 digits



J: EAN8 + 5 digits



K: UPC-A



L: UPC-A + 2 digits



M: UPC-A + 5 digits



N: UCC/EAN128



O: Industrial 2 of 5



P: PDF417

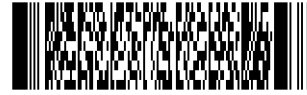

Q: Data Matrix

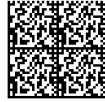

R: Customer bar code



S: Highest priority customer bar code



T: QR code



U: POSTNET



V: RM4SCC



W: KIX code



X: MicroPDF417



Z: MaxiCode

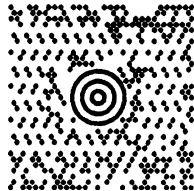

(4) Type of check digit

- ① Where no check digit is attached, the bar code of the data row will be drawn.
- ② In the case of the check digit check, if each check digit checked according to the type of bar code is normal, the bar code will be drawn. If the check digit not meeting the requirement is designated, the bar code will not be drawn.
- ③ In the case of the check digit auto attachment, each check digit is attached according to the type of bar code and the bar code is drawn.
- ④ If the type of bar code is CODE93, CODE128 (with auto code selection), or UCC/EAN128, the check digit will always be attached regardless of the designation of the type of check digit.
- ⑤ If the type of bar code is JAN, EAN, or UPC, the designation of no check digit attachment automatically assume the check digit check.
- ⑥ DBP Modulus 10 is Modulus 10 for Deutsche Bundespost Postdienst only.

(5) Bar width, space width, and character-to-character space

Designate the bar, space, and character-to-character space widths according to the type of bar code. Note that the designated proper value differs according to the rotational angle of bar code, type, number of digits, print speed, paper to be used, etc. Examples of such designation are listed below. (1 dot = 1/11.8 mm)

In the case of JAN, EAN, UPC, CODE93, CODE128, UCC/EAN128, PDF417, or MicroPDF417, 2 to 6-module width is calculated automatically when 1-module width is designated.

Type of bar code	1 module		2 modules		3 modules		4 modules		5 modules		6 modules	
	Bar	Space	Bar	Space	Bar	Space	Bar	Space	Bar	Space	Bar	Space
JAN, EAN, UPC	4		8		12		16		-		-	
CODE93	3		6		9		12		-		-	
CODE128, EAN128	3		6		9		12		-		-	
PDF417	3		6		9		12		15		18	
MicroPDF417	2		4		6		8		10		12	

Type of bar code	Narrow		Wide		Character-to-character
	Bar	Space	Bar	Space	
MSI	3	3	8	8	0
ITF	3	3	8	8	0
CODE39	3	3	8	8	3
NW7	3	3	8	8	3
Industrial 2 of 5	3	3	8	0	3

In the case of Data Matrix

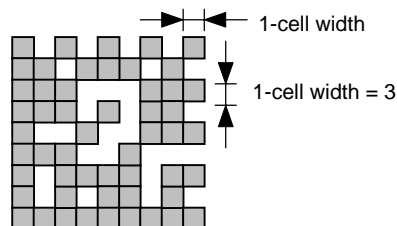

When 1-cell width is 00 for the Data Matrix, a two-dimensional code is not drawn. However, the bar code printed on the previous label is cleared.

In the case of QR code

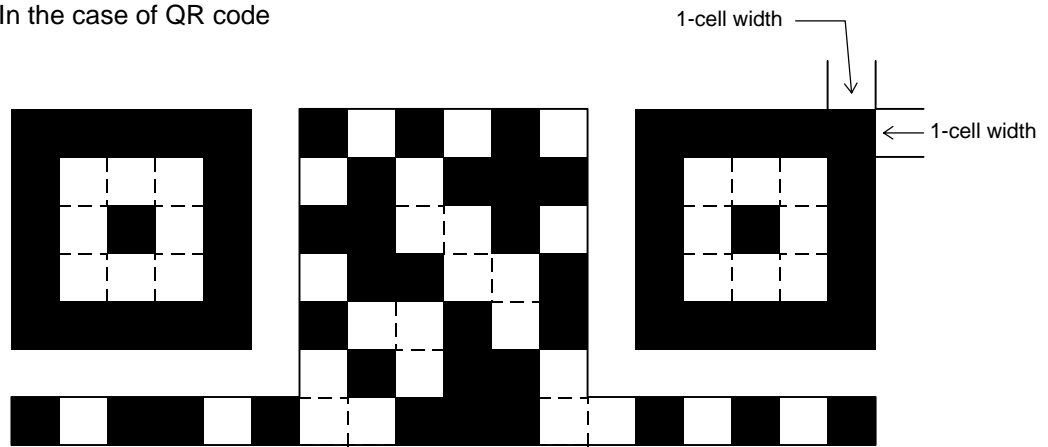

When the 1-cell width is 0, a two-dimensional code is not drawn. However, the bar code printed on the previous label is cleared.

In the case of a postal code

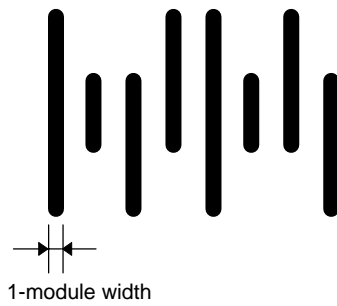

When NW7 is used, transmission of the space character assumes the space of (narrow space x 12) dots. In this case, the space is max. 255 dots.

(6) Rotational angle of bar code

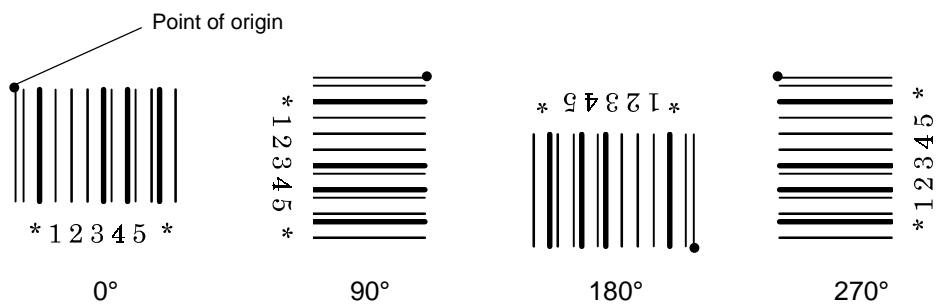

In the case of Data Matrix

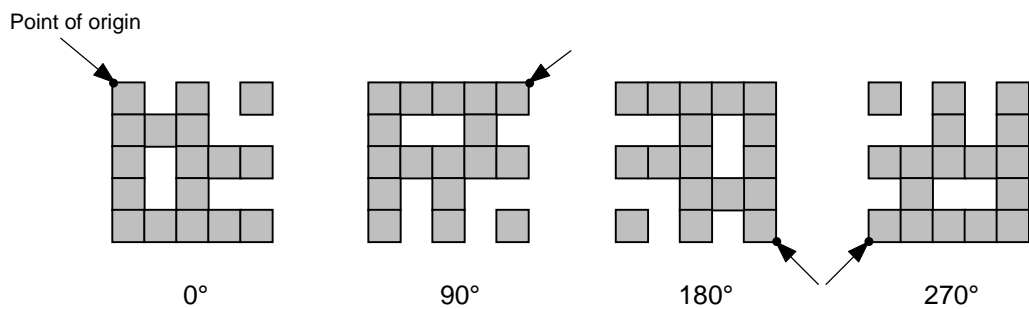

In the case of QR code

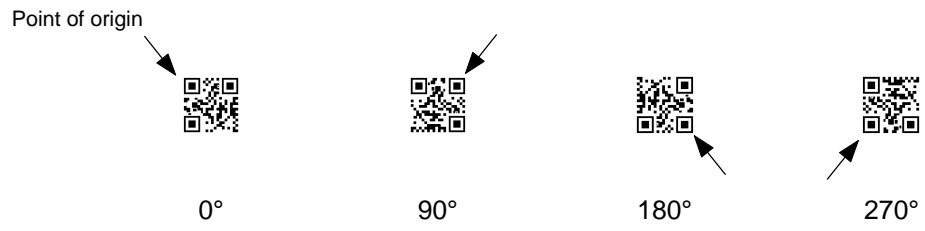

(7) Bar code height

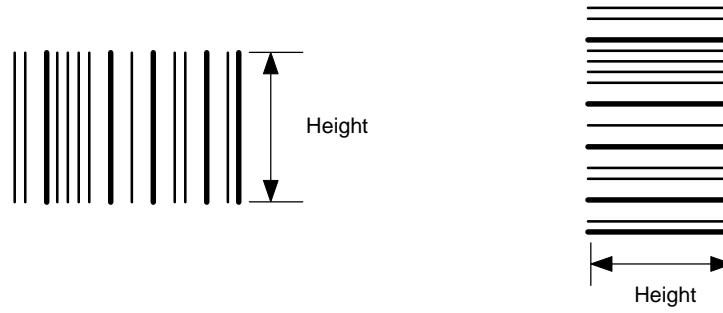

[PDF417, MicroPDF417]



[Postal code]

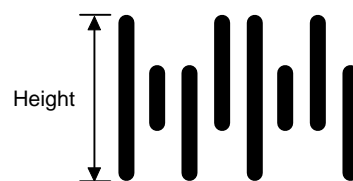

When the bar code height is 0000, bar code (including guard bar) and numerals under bars are not drawn. However, the bar code printed on the previous label is cleared.

(8) Length of guard bar

The length of guard bar is valid only when the type of bar code is WPC. It is ignored in any other cases.

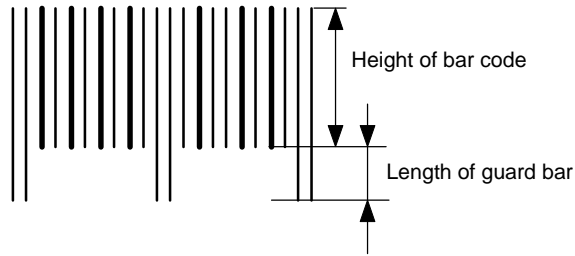

(9) Numerals under bars

Numerals are not or provided under bars according to the parameter for the presence or absence of numerals under bars. The contents of numerals under bars to be printed vary according to the type of bar code. The character set of numerals under bars is OCR-B. Such numerals are enlarged or reduced only horizontally according to the width of the bar code. They are drawn vertically in the fixed one magnification.

[Drawing positions of numerals under bars]

- ① In the case of JAN and EAN
(Example) EAN13 + 2 digits



(Example) EAN8



- ② In the case of UPC
 (Example) UPC-A + 2 digits



- (Example) UPC-E



- ③ In the case of other than JAN, EAN, and UPC
 (Example) CODE39

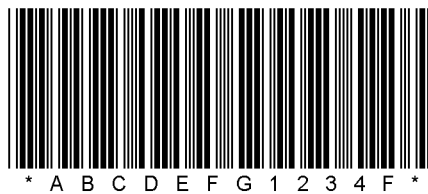

- (Example) UCC/EAN128

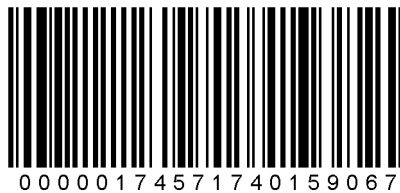

(10) Start/Stop Code

- This parameter is valid only when the type of bar code is CODE39 and NW7.
- Where the parameter is designated, the program will not check if the transmit print data is with a start code and stop code.
- When the parameter is omitted in the case of CODE39 and NW7, a start/stop code will be attached. The code to be added is "*" in the case of CODE39, and "a" in the case of NW7.
- For details, refer to "Auto Attachment of Start/Stop Code" to be discussed later in this specification.

(11) Increment/decrement

Printing is performed while the data is incremented or decremented each time a label is issued.

Where the data row exceeds the maximum number of digits (40), the data row will not be drawn.

When CODE128 (without auto code selection) is used, the number of the start code (code A, code B, and code C) digits is regarded as 2.

Initial value	0000	0000	0000	0000	999999
INC/DEC	+10	+10	+10	+10	+1
Zero suppression	Not designated	5	3	0	3
1st label	0000	0000	└000	0000	999999
2nd label	0010	0010	└010	0010	└└└000
3rd label	0020	0020	└020	0020	└└└001
4th label	0030	0030	└030	0030	└└└002
5th label	0040	0040	└040	0040	└└└003

Letters and numerals for increment/decrement

For CODE39 (standard), CODE39 (full ASCII), NW-7, CODE93, and CODE128, if a data string other than numerals is included in the data, increment/decrement designation is performed. If any code which does not exist in each bar code table is contained in the data, increment/decrement designation is not performed.

Up to 40 digits (including letters, numerals and symbols) are possible.

Example of increment/decrement calculation

Initial value	00000	A0A0A	7A8/9	A2A0A
INC/DEC	+1	+1	+3	-3
1st label	00000	A0A0A	7A8/9	A2A0A
2nd label	00001	A0A1A	7A9/2	A1A7A
3rd label	00002	A0A2A	7A9/5	A1A4A
4th label	00003	A0A3A	7A9/8	A1A1A
5th label	00004	A0A4A	8A0/1	A0A8A

Example of increment/decrement of data including the special codes of CODE128

Increment/decrement calculation starts from the last digit in the data strings. When the data string to be calculated is numeric, and the next (upper) digit is ">", that is a special code (shown with underline below). The next digit is calculated without incrementing/decrementing these two digits.

Example of increment/decrement calculation of CODE128

Initial value	00000	00>08	0A>08	0A9>08
INC/DEC	+1	+1	+1	+1
1st label	00000	00>08	0A>08	0A9>08
2nd label	00001	00>09	0A>09	0A9>09
3rd label	00002	01>00	1A>00	1A0>00
4th label	00003	01>01	1A>01	1A0>01
5th label	00004	01>02	1A>02	1A0>02

(12) Zero suppression

No. of zeros to be suppressed	0	1	2	2	3	4	5
Data	0000	0000	0000	0A12	0123	0123	0123
Print	0000	0	00	A12	123	0123	0123

The leading zero(s) in a data row is replaced by a space(s) according to the designated number of digits. However, if the number of digits to be suppressed is greater than the data row, the data row will be drawn without zero suppression. Where the data row exceeds the maximum number of digits (40), the data row will not be drawn.

When the print data including start/stop code is sent, the start/stop code is also counted as a digit. When the bar code type is JAN, EAN, UPC or UCC/EAN 128, the data will be drawn without zero suppression.

(13) Data string to be printed

Drawing data can be programmed by designating the number of digits after the symbol “=”.” The maximum number of digits to be printed varies according to the types of bar codes. For codes, refer to the bar code table mentioned later.

(14) Link field No.

The link field No. can be programmed by designating it after the symbol “;”. After the link field No. is designated using the Format Command, the data strings are linked by the Link Field Data Command to draw an image.

Up to 20 fields can be linked.

The following shows an example of linked fields on the two continuous labels.

[Format Command]

- {PC01; ; 01} : Link field No. 1 is designated.
- {PC02; ; 03} : Link field No. 3 is designated.
- {PC03; ; 04} : Link field No. 4 is designated.
- {XB01; ; 03, 04} : Link fields No. 3 and No. 4 are designated.

- {PC04; ; 02} : Link field No. 2 is designated.
- {PC05; ; 03} : Link field No. 3 is designated.
- {PC06; ; 04} : Link field No. 4 is designated.
- {XB02; ; 03, 04} : Link fields No. 3 and No. 4 are designated.

└── Designating link field No.

[Data Command]

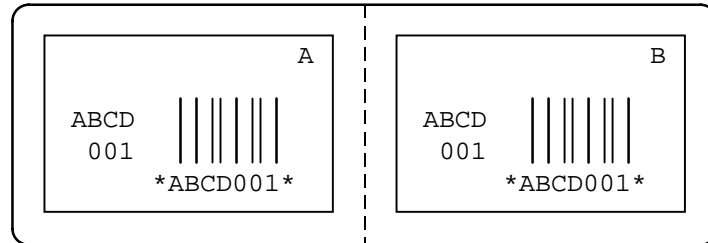
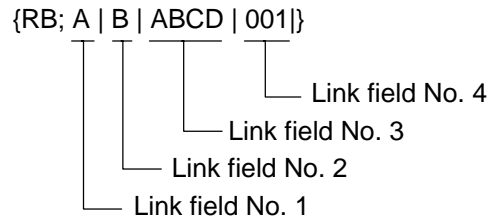

(15) Explanation for Data Matrix

① ECC type

Data Matrix contains a function to correct a code reading error using an error correcting code (ECC) and restore normal data. There are several ECCs and ECC is designated according to usage. The general correction ability is as follows. However, it may vary according to the error conditions.

ECC type	Error Correction Ability	Overhead by ECC
ECC0	<div style="text-align: center;"> <div style="border: 1px solid black; padding: 5px; width: fit-content; margin: 0 auto;">Low</div> <div style="font-size: 2em; margin: 5px 0;">↕</div> <div style="border: 1px solid black; padding: 5px; width: fit-content; margin: 0 auto;">High</div> </div>	0%
ECC50		25%
ECC80		33%
ECC100		50%
ECC140		75%
ECC200		Approx. 30%

② Format ID (It is invalid for ECC200.)

Data Matrix can handle all codes including alphanumerics, symbols and Kanji. Since data compression rate varies according to codes, a code to be used is designated using the format ID.

Format ID	Code	Details
1	Numerics	0 to 9 space
2	Letters	A to Z space
3	Alphanumerics, symbols	0 to 9 A to Z space . , - /
4	Alphanumerics	0 to 9 A to Z space
5	ASCII (7 bit)	00H to 7FH
6	ISO (8 bit)	00H to FFH (Kanji)

③ Maximum number of digits

The maximum number of digits varies according to the ECC type or format ID. Since each Kanji character uses 2 bytes, the maximum number of digits for it becomes half of the following values.

ECC ID	0	50	80	100	140
1	500	457	402	300	144
2	452	333	293	218	105
3	394	291	256	190	91
4	413	305	268	200	96
5	310	228	201	150	72
6	271	200	176	131	63

	Numeric	Alphanumeric	8 bit
ECC200	2000	2000	1556

④ Connection setting

The connection setting is used to comprise data with a set of two-dimensional codes when the data cannot be expressed with a two-dimensional code. When three two-dimensional codes are used to comprise data, identification information of 1/3, 2/3, and 3/3 is inserted into each two-dimensional code. The ID number is programmed to include a proper combination of two-dimensional codes when one label contains plural connecting symbols. For example, when there are two kinds of data containing identification information for 1/2 and 2/2 in the same label, combination of two dimensional codes is unclear. By adding the ID number, the combination is made clear.

(16) Explanation for the PDF417 and MicroPDF417

① Security level

The PDF417 contains a function to correct a code reading error using an error correcting code word and restore normal data. The security level is designated according to usage to perform the error correction function.

For the MicroPDF417, the printer sets the security level automatically.

Security level	Error Correction Ability	No. of error correction code words
Level 0	<div style="display: flex; flex-direction: column; align-items: center;"> <div style="border: 1px solid black; padding: 2px 10px;">Low</div> <div style="margin: 5px 0;">↑</div> <div style="margin: 5px 0;">↓</div> <div style="border: 1px solid black; padding: 2px 10px;">High</div> </div>	0
Level 1		2
Level 2		6
Level 3		14
Level 4		30
Level 5		62
Level 6		126
Level 7		254
Level 8		510

② No. of columns (strings)

The number of lines is variable in the PDF417. The line length (No. of data strings) is also variable. Therefore, a symbol can be created in a form that can be easily printed, by changing the proportion of the height and width.

The number of columns (data strings) is variable between 1 to 30.

If the number of columns is small when data amount is large and security level is also high, drawing may not be performed. This is because the number of lines exceeds 90 when the number of columns becomes small. (When the PFD417 is used, the number of lines of symbols is limited from 3 to 90.)

For the MicroPDF417, not only the number of columns (data strings) but also the number of rows (data lines) can be designated. When these are to be designated, see the table on page 86. Note that the maximum number of digits for the set parameter (gg) varies according to the character type. If data over the maximum number of digits for the set parameter (gg) is set, it is not printed. The number of columns (data strings) is variable from 1 to 4. The maximum number of lines is 44. However it depends on the number of columns.

(17) Explanation for QR code

① Error correction level

The QR code contains functions to detect and correct an error. If one of the data characters is damaged, the information can be restored when this code is read. There are 4 levels that can be designated. The general correction ability is as follows.

Level	Error correction ability	Overhead by correcting an error
High density level	<div style="display: flex; flex-direction: column; align-items: center;"> <div style="margin-bottom: 5px;">Low</div> <div style="margin: 5px 0;">↑</div> <div style="margin: 5px 0;">↓</div> <div style="margin-top: 5px;">High</div> </div>	7%
Standard level		15%
Reliability level		25%
High reliability level		30%

② Selection of mode

All codes including alphanumerics, symbols, and Kanji can be used in one QR code. Manual mode or automatic mode can be selected to perform the operation.

③ Selection of model

Model 1 : Original specification

Model 2 : Extended specification which enhances the function of position correction and contains a large amount of data.

④ Mask number

To be sure to read the QR code, it is preferable that white and black modules are arranged in this symbol in a balanced manner. This prevents the bit pattern "1011101", which is characteristically seen in the position detecting pattern, from appearing in the symbol as much as possible.

The mask number is 0 to 7. The pattern is determined by placing each masking pattern for the mask number upon the module pattern. When the mask number is set to 8, masking is not performed. When the parameter is omitted, the most appropriate mask number is automatically selected to perform masking.

⑤ Connection setting

For QR code, data can be divided into several codes. Even though there is only a narrow print space, the code can be entered in the space by dividing the code. The data can be divided into a max. of 16 codes. Parity data is obtained by EX-ORing all input data in units of bytes before dividing. The input data is calculated based on shift JIS for Kanji, or on JIS 8 for others. Examples are shown below:

"012345678日本" is divided into "0123," "4567" and "89日本".

Code No. 1	No. of divided codes: 3	Parity data: 85	Data "0123"
Code No. 2	No. of divided codes: 3	Parity data: 85	Data "4567"
Code No. 3	No. of divided codes: 3	Parity data: 85	Data "89日本"

* The parity data is the EX-ORed value for "0123456789日本".

30 31 32 33 34 35 36 37 38 39 93 FA 96 7B = 85

(18) Explanation for MaxiCode

① Connection setting

For MaxiCode, data can be divided into a max. of 8 codes.

Notes

(1) The check digit attach, increment/decrement, and zero suppress processes are performed according to the following priority. If any of the conditions is improper, no drawing will take place.

[For example, the zero(s) is replaced by a space(s) as a result of zero suppression but the modulus 10 designated to be attached cannot be calculated.]

Increment/decrement > zero suppression > attachment of check digit

(2) Up to 32 fields for which incrementing/decrementing has been designated can be drawn. If a total of bit map font, outline font or bar code increment/decrement fields exceeds 32, drawing will take place without incrementing/decrementing any excessive field. The field to be incremented or decremented is incremented or decremented until the Image Buffer Clear Command ({C) is transmitted.

[Example]

- ① Format Command (Increment bar code No. 01 (+1))
- ② Format Command (Increment bar code No. 02 (+2))
- ③ Image Buffer Clear Command
- ④ Data Command (Bar code No. 01 "0001")
- ⑤ Data Command (Bar code No. 02 "0100")
- ⑥ Issue Command (2 labels)

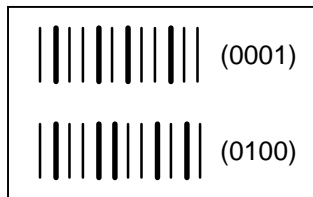

- ⑦ Issue Command (1 label)



- ⑧ Image Buffer Clear Command
- ⑨ Data Command (Bar code No. 02 "3000")
- ⑩ Issue Command (1 label)

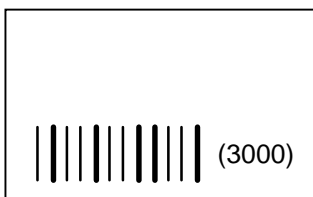

- (3) More than one Bar Code Format Command can be connected when transmitted.

```
{XB01; 0100, 0150, 3, 1, 02, 02, 06, 06, 02, 0, 0150|  
B02; 0350, 0150, 3, 1, 02, 02, 06, 06, 02, 0, 0150}
```

- (4) When the drawing data is changed per label issue during printing, the field of the drawing data for the previous label is automatically cleared using the bar code number, then the next drawing data is printed. Therefore, the bar code number which differs according to the drawing fields should be designated. Since the automatic field clear is not performed between the Clear Command ({C) and Issue Command ({XS), the fixed data may be drawn using the same bar code number. In this case, the Format Command and Data Command should be sent alternately. (After the Issue Command is sent, the fields with the same bar code number are automatically cleared until the Clear Command is sent.)
- (5) The link field designation is cleared by omitting the link field designation using the same bar code No. and reformatting data.
The link field designation can be also cleared by the Image Buffer Clear Command.
- (6) A print data string and link field No. cannot be programmed at the same time.

Refer to

Bit Map Font Format Command ({PC)
Outline Font Format Command ({PV)
Bar Code Data Command ({RB)

Examples

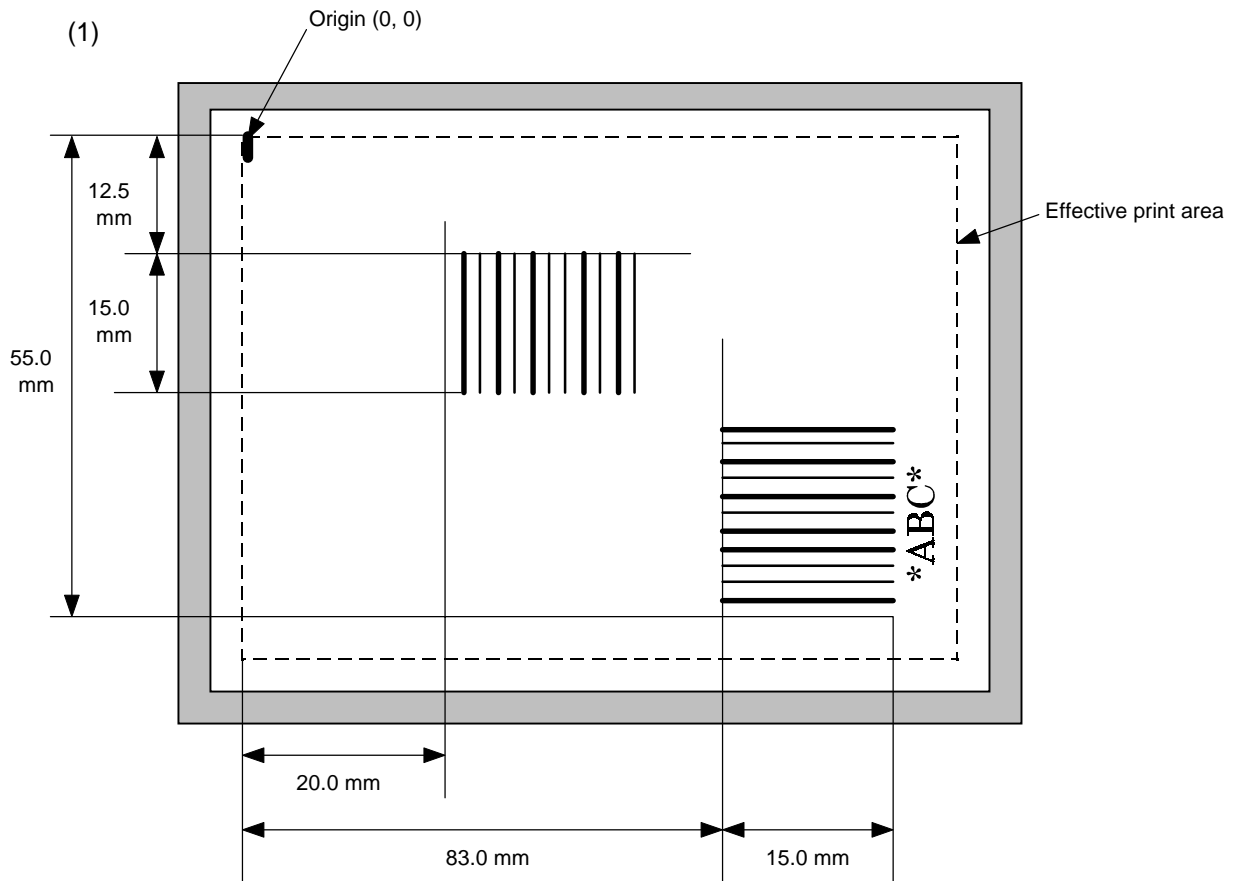

```
{C}
{XB01; 0200, 0125, 3, 1, 03, 03, 08, 08, 03, 0, 0150=12345}
{XB02; 0830, 0550, 3, 1, 02, 04, 07, 08, 04, 3, 0150, +0000000000, 1, 00, N}
{RB02; * ABC *}
{XS; I, 0002, 0002C2000}
```

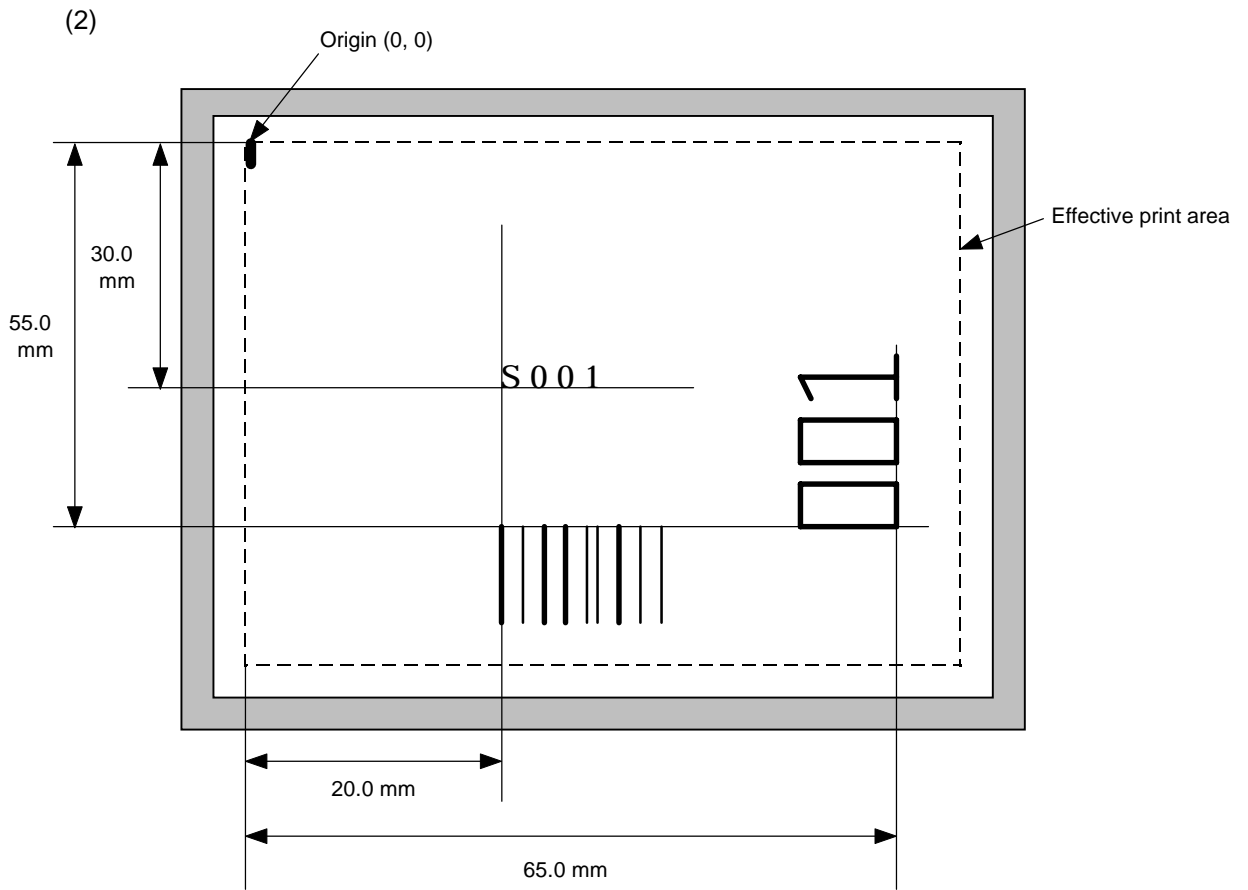

```

{C}
{PC001; 0200, 0300, 1, 1, C, 00, B; 01, 02}
{PV01; 0650, 0550, 0200, 0150, B, 33, B; 02}
{XB01; 0200, 0550, 3, 1, 03, 03, 08, 08, 03, 0, 0150; 01, 02}
{RB; S | 001}
{XS; I, 0002, 0002C2000}
  
```

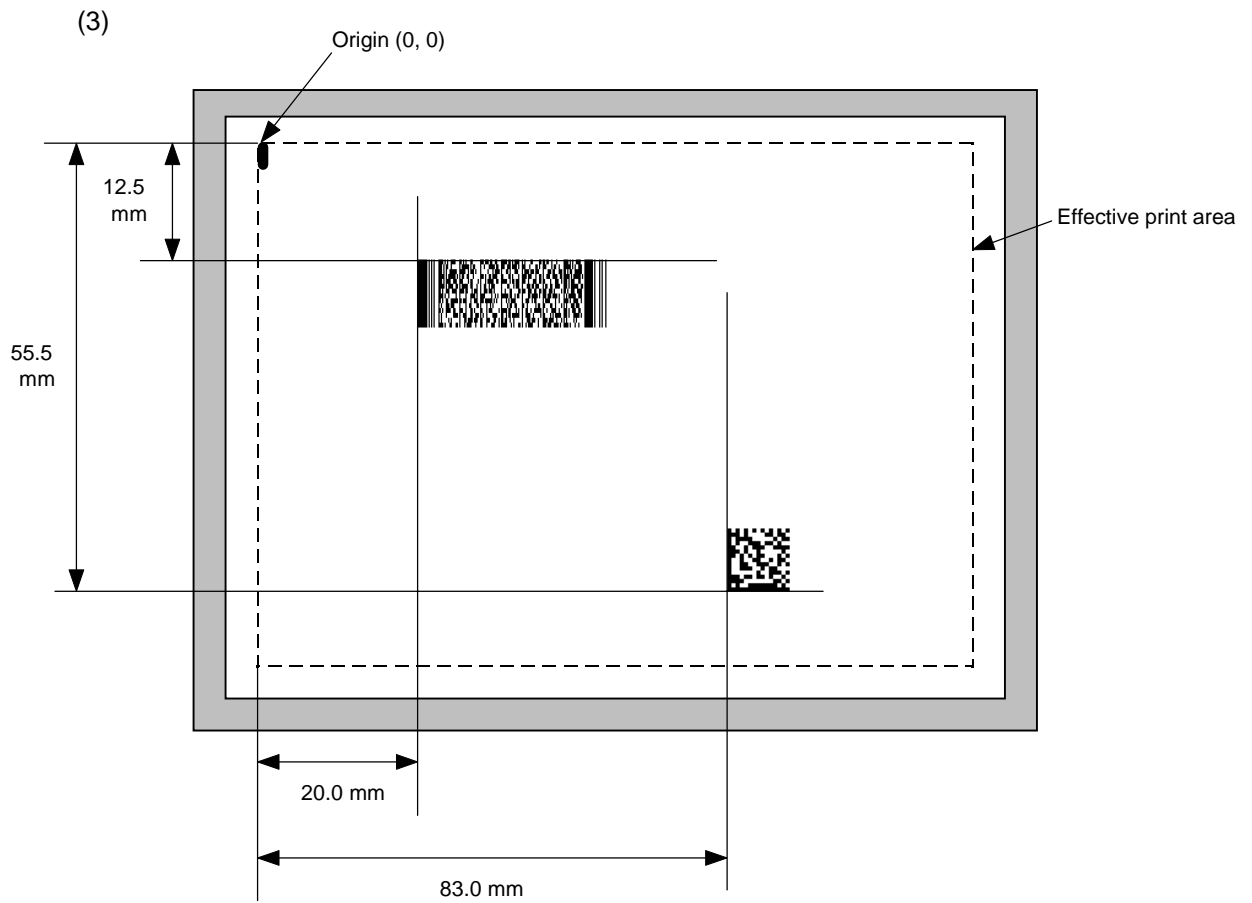

```

{C}
{XB01; 0200, 0125, P, 04, 02, 03, 0, 0010}
{XB02; 0830, 0550, Q, 08, 03, 05, 3}
{RB01; PDF417}
{RB02; Data Matrix}
{XS; I, 0002, 0002C2000}

```

6.13 BIT MAP FONT DATA COMMAND

{RC

Function	Provides data for the bit map font row.
Format	① {RCaaa; bbb ----- bbb} ② Link Field Data Command {RC; ccc ----- ccc ddd ----- ddd ----- xxx ----- xxx}
Term	aaa: Character string number 000 to 199 (Two digits, 00 to 99, also acceptable) bbb ----- bbb: Data string to be printed Max. 255 digits (Max. 127 digits when the font type is U, V, W or X) Any excess data will be discarded. For the character codes, refer to the character code table to be given later in this specification. ccc ----- ccc: Data string of link field No. 1 ddd ----- ddd: Data string of link field No. 2 to xxx ----- xxx: Data string of link field No. 99
Explanation	(1) Link field data string <ul style="list-style-type: none">• After the link field No. is designated in the Format Command, data strings are linked using the Link Field Data Command to draw an image.• Up to 255 digits of data strings can be linked. When the number of digits exceeds the maximum value, exceeding data will be discarded.• Up to 99 types of data strings can be linked.• Up to 2048 bytes can be used as the command length ({ to }) of the Link Field Data Command.• When the data string is omitted in the Link Field Data Command, the following processing is performed:<ul style="list-style-type: none">① No processing will be performed for the field which contains no print data due to the omission.② When the field partially loses print data due to the omission, the only remaining data will be processed as print data.• The Link Field Data Command can be used for the bit map font fields, outline font fields, and bar code fields. (The same result is obtained when any of the “RC,” “RV” or “RB” command code is designated.)

Refer to

Bit Map Font Format Command ({PC}

Examples

(1)

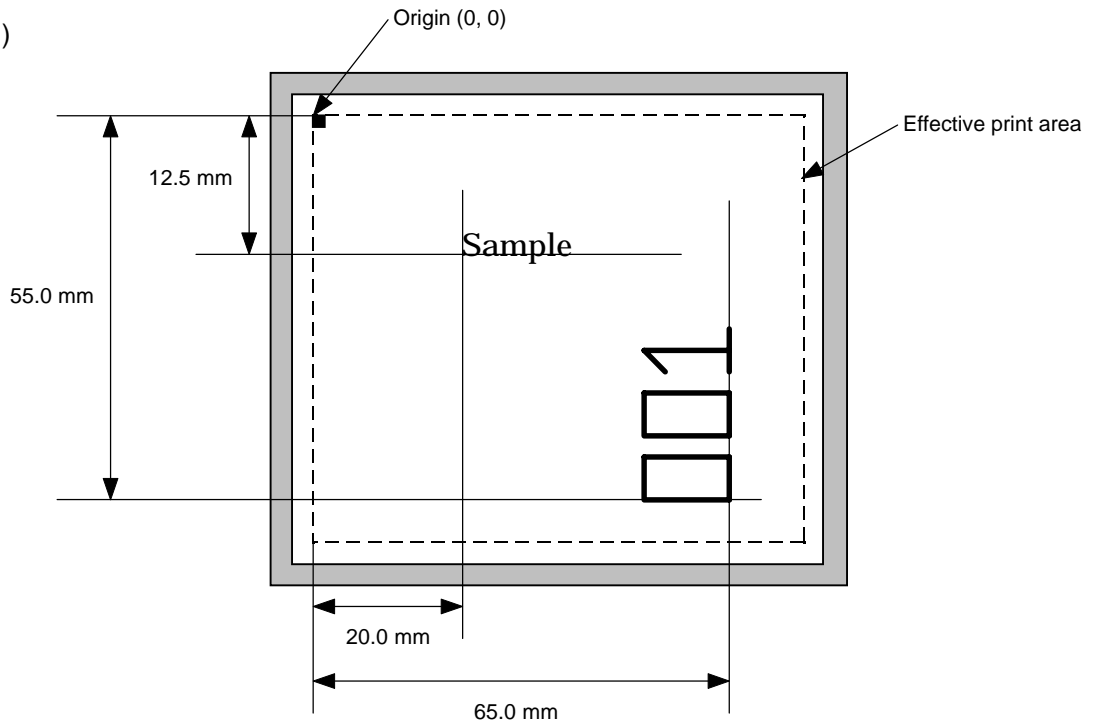

{C}

{PC001; 0200, 0125, 1, 1, C, 00, B}

{PC002; 0650, 0550, 2, 2, G, 33, B, +0000000001}

{RC001; Sample}

{RC002; 001}

{XS; I, 0002, 0002C2000}

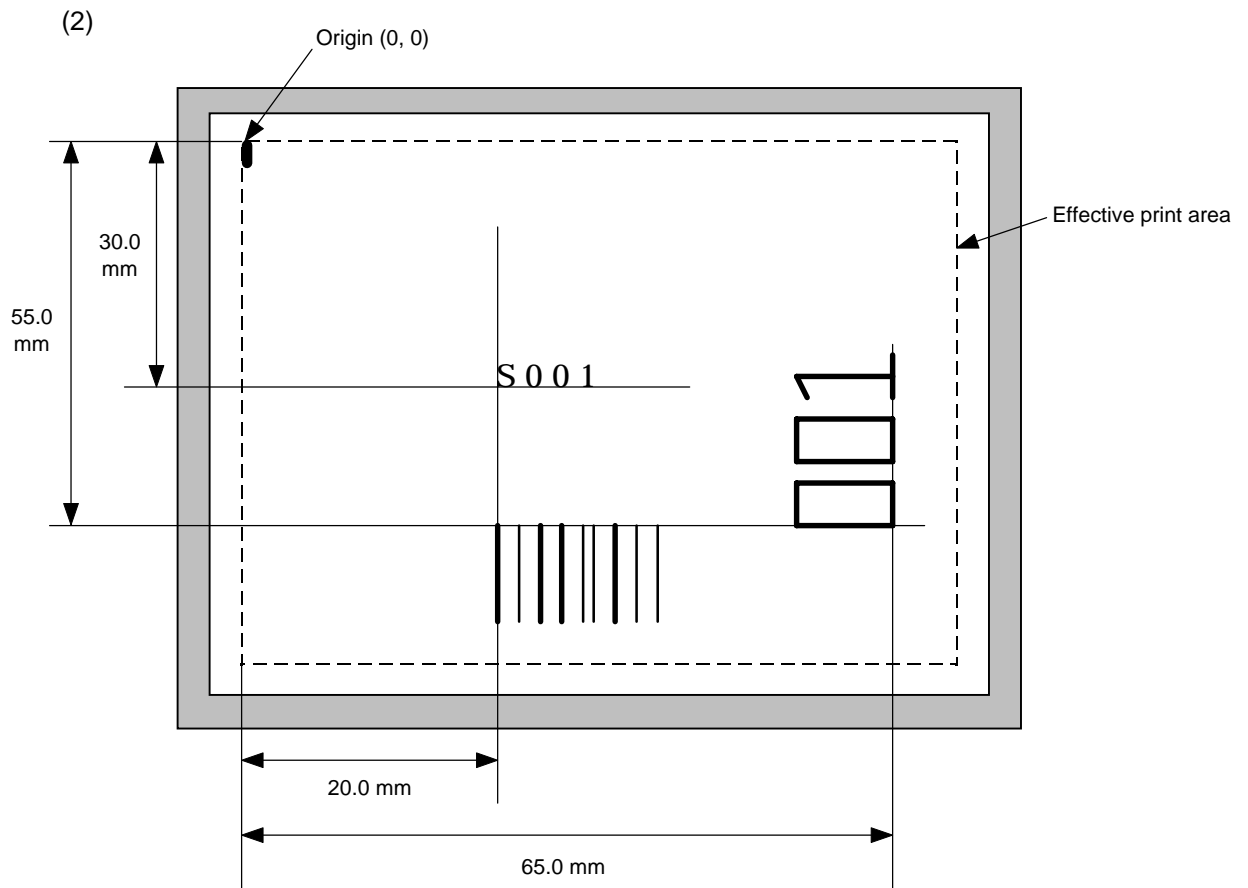

{C]}

{PC001; 0200, 0300, 1, 1, C, 00, B; 01, 02]}

{PV01; 0650, 0550, 0200, 0150, B, 33, B; 02]}

{XB01; 0200, 0550, 3, 1, 03, 03, 08, 08, 03, 0, 0150; 01, 02]}

{RC; S | 001]}

{XS; I, 0002, 0002C2000]}

6.14 OUTLINE FONT DATA COMMAND

{RV

Function	Provides data for the outline font row.
Format	① {RVaa; bbb ----- bbb} ② Link Field Data Command {RV; ccc ----- ccc ddd ----- ddd ----- xxx ----- xxx }
Term	aa: Character string number 00 to 99 bbb ----- bbb: Data string to be printed Max. 255 digits Any excess data will be discarded. For the character codes, refer to the character code table to be given later in this specification. ccc ----- ccc: Data string of link field No. 1 ddd ----- ddd: Data string of link field No. 2 to xxx ----- xxx: Data string of link field No. 99
Explanation	(1) Link field data string <ul style="list-style-type: none">• After the link field No. is designated in the Format Command, data strings are linked using the Link Field Data Command to draw an image.• Up to 255 digits of data strings can be linked. When the number of digits exceeds the maximum value, exceeding data will be discarded.• Up to 99 types of data strings can be linked.• Up to 2048 bytes can be used as the command length ({ to }) of the Link Field Data Command.• When the data string is omitted in the Link Field Data Command, the following processing is performed:<ul style="list-style-type: none">① No processing will be performed for the field which contains no print data due to the omission.② When the field partially loses print data due to the omission, the only remaining data will be processed as print data.• The Link Field Data Command can be used for the bit map font fields, outline font fields, and bar code fields. (The same result is obtained when any of the “RC,” “RV” or “RB” command code is designated.)

Refer to

Outline Font Format Command ({PV})

Examples

(1)

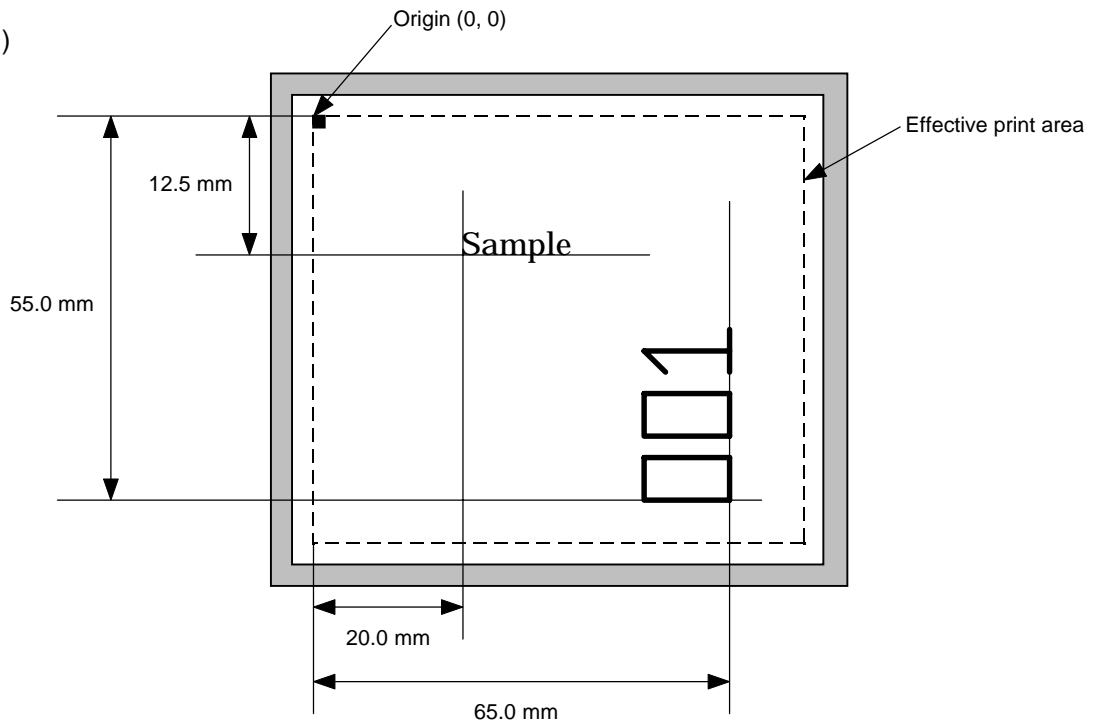

{C|}

{PV01; 0200, 0125, 0100, 0100, B, 00, B|}

{PV02; 0650, 0550, 0200, 0150, B, 33, B, +0000000001|}

{RV01; Sample|}

{RV02; 001|}

{XS; I, 0002, 0002C2000|}

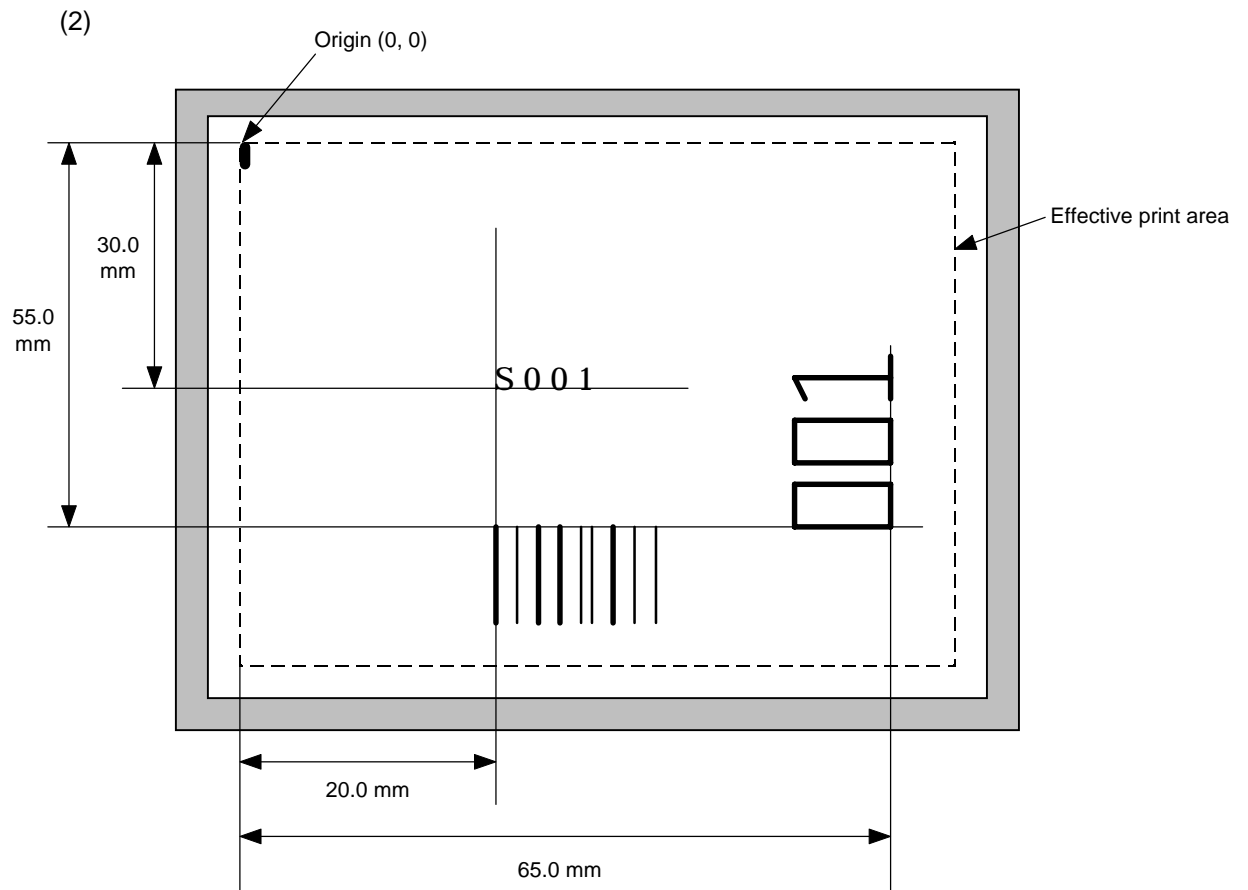

```

{C}
{PC001; 0200, 0300, 1, 1, C, 00, B; 01, 02}
{PV01; 0650, 0550, 0200, 0150, B, 33, B; 02}
{XB01; 0200, 0550, 3, 1, 02, 02, 06, 06, 02, 0, 0150; 01, 02}
{RV; S | 001}
{XS; I, 0002, 0002C2000}

```

6.15 BAR CODE DATA COMMAND

{RB

Function	Provides data for the bar code.
Format	<p>① {RBaa; bbb ----- bbb}</p> <p>② Link Field Data Command {RB; ccc ----- ccc ddd ----- ddd ----- xxx ----- xxx}</p>
Term	<p>aa: Bar code number 00 to 31</p> <p>bbb ----- bbb: Data string to be printed The maximum number of digits varies according to the type of bar code.</p> <p>ccc ----- ccc: Data string of link field No. 1</p> <p>ddd ----- ddd: Data string of link field No. 2 to</p> <p>xxx ----- xxx: Data string of link field No. 99</p>

Explanation	<p>(1) Data check</p> <p>If there is data in the data row, which does not meet the type of bar code, the bar code will not be drawn. If wrong code selection takes place in the data row of CODE128 (no auto code selection), the bar code will not be drawn.</p> <p>If there is data different from the one designated using the format ID when Data Matrix is used, the symbol is not drawn.</p> <p>(2) No. of digits of data</p> <p>When data exceeding the maximum number of digits is sent, the excessive data will be discarded. For the maximum number of digits for each bar code, see below.</p> <p>Data Matrix, PDF417, QR code: 2000 digits MicroPDF417: 366 digits Bar codes other than the above: 126 digits</p> <p>When the number of digits does not correspond to the bar code type, the bar code is not be drawn.</p> <p>The maximum number of digits for Data Matrix varies according to the ECC type and format ID. In the case of Kanji, the maximum number of digits is half those of the values described below since a Kanji character occupies 2 bytes.</p>
-------------	---

ID \ ECC	ECC				
	0	50	80	100	140
1	500	457	402	300	144
2	452	333	293	218	105
3	394	291	256	190	91
4	413	305	268	200	96
5	310	228	201	150	72
6	271	200	176	131	63

	Numeric	Alphanumeric	8 bit
ECC200	2000	2000	1556

When PDF417 or MicroPDF417 is used, the number of symbol characters called code words is limited to 928 or less. Moreover, the data compression rate varies according to the contents of data. Therefore, the maximum number of digits according to modes is as below.

When letters and numerics are mixed in data in EXC mode, for example, the maximum values become smaller than the values below, since the internal mode switching code is used.

To correct a reading error by designating the security level, the maximum value becomes smaller, since the error correction code words in the table below are used.

When the number of digits of the code word exceeds 928, or when the number of lines exceeds 90, the symbols are not drawn.

- Extended Alphanumeric Compaction (EXC) mode: 1850 digits
- Binary/ASCII Plus mode: 1108 digits
- Numeric compaction mode: 2000 digits

In the case of MicroPDF417

- Binary mode: 150 digits
- Upper case letter/space mode: 250 digits
- Numeric compaction mode: 366 digits

No. of Error Correction Code Words of PDF417 [For the MicroPDF417, the printer sets the security level automatically.]

Security level	Error Correction Ability	No. of error correction code words
Level 0	<div style="display: flex; flex-direction: column; align-items: center;"> <div style="border: 1px solid black; padding: 5px; margin-bottom: 10px;">Low</div> <div style="margin: 0 10px;">↑</div> <div style="margin: 0 10px;">↓</div> <div style="border: 1px solid black; padding: 5px; margin-top: 10px;">High</div> </div>	0
Level 1		2
Level 2		6
Level 3		14
Level 4		30
Level 5		62
Level 6		126
Level 7		254
Level 8		510

(3) CODE128 code selection

If the case of CODE128 (with auto code selection), code selection is performed in the following manner. (Conforming to USS-128 APPENDIX-G)

- ① Determining the start character
 - (a) If the data begins with four or more consecutive numerals, the start code to be used is (CODE C).
 - (b) In any case other than (a) in ①, if a control character appears before a small letter (see 4) or four or more consecutive numerals, the start code is (CODE A).
 - (c) In none of the above cases, the start code is (CODE B).
- ② If the data begins with an odd number of digits in (a), ①:
 - (a) Insert the (CODE A) or (CODE B) character just before the last numeric data. When (FNC1), if found in the number, breaks a pair of digits in the number, insert the (CODE A) or (CODE B) character before the numeric data preceding the (FNC1). Selection of (CODE A) or (CODE B) should conform to (b) and (c) in ①.
- ③ If four or more digits of numeric data continue in (CODE A) or (CODE B).
 - (a) When the numeric data is an even number of digits, insert the (CODE C) character just before the first numeric data.
 - (b) When the numeric data is an odd number of digits, insert the (CODE C) character immediately after the first numeric data.
- ④ If a control character appears in (CODE B):
 - (a) In the subsequent data, when a small letter appears before the next control character or four or more consecutive digits, insert the (SHIFT) character before the first control character.
 - (b) When not so, insert the (CODE B) character just before the first control character.
- ⑤ If a small letter appears in (CODE A):
 - (a) In the subsequent data, when a control character appears before the next small letter or four or more consecutive digits, insert the (SHIFT) character before the first small letter.
 - (b) When not so, insert the (CODE B) character just before the first small letter.
- ⑥ If any data other than the numerals appears in (CODE C):
 - (a) Insert the (CODE A) or (CODE B) character just before the data other than the numerals. Selection of (CODE A) or (CODE B) should conform to (b) and (c) in ①.

(4) CODE128 code selection check

Check if selection of (CODE A), (CODE B) or (CODE C) of CODE128 has been set correctly. If an error is found, the bar code will not be drawn.

[Conditions causing an error]

- ① No start code is designated.
- ② A small letter (including { , | , } , ~ , _) is found in (CODE A).
- ③ A control character is found in (CODE B).
- ④ Any data other than the numerals, (FNC1), (CODE A), and (CODE B) is found in (CODE C).
- ⑤ There are two or more consecutive (SHIFT) characters.
- ⑥ The number in (CODE C) is an odd number of digits.
- ⑦ (SHIFT) is followed by (CODE A), (CODE B) or (CODE C).

(5) Kanji code selection

- In the case of Data Matrix and PDF417, Kanji codes can be printed. Shift JIS, JIS hexadecimal, JIS 8 codes can be mixed.

(6) Link field data string

- After the link field No. is designated in the Format Command, data strings are linked using the Link Field Data Command to draw an image.
- Up to 2000 digits of data strings of Data Matrix, PDF417, and QR code can be linked. For other bar codes, up to 126 digits can be linked. (The value varies according to the type of bar code.)
When the number of digits exceeds the maximum value, exceeding data will be discarded.
- Up to 99 types of data strings can be linked.
- Up to 2048 bytes can be used as the command length ({ to }) of the Link Field Data Command.
- When the data string is omitted in the Link Field Data Command, the following processing is performed:
 - ① No processing will be performed for the field which contains no print data due to the omission.
 - ② When the field partially loses print data due to the omission, the only remaining data will be processed as print data.
- The Link Field Data Command can be used for the bit map font fields, outline font fields, and bar code fields.
(The same result is obtained when any of the "RC," "RV" or "RB" command code is designated.)

(7) MaxiCode data

For mode 2 or 3:

{RBaa; bbbbbbccccdddeeee --- eeee}

For mode 4 or 6:

{RBaa; ffffffffggggg --- gggg}

- | | | | |
|---|---------------|--------------------------------|---|
| ① | bbbbbbb: | Postal code | Fixed as 9 digits |
| | • Mode 2: | | |
| | b1b2b3b4b5: | Zip code | Fixed as 5 digits (Numerics) |
| | b6b7b8b9: | Zip code extension | Fixed as 4 digits (Numerics) |
| | • Mode 3: | | |
| | b1b2b3b4b5b6: | Zip code | Fixed as 6 digits (Character "A" of code set) |
| | b7b8b9: | Vacant | Fixed as 3 digits (20H) |
| ② | ccc: | Class of service | Fixed as 3 digits (Numerics) |
| ③ | ddd: | Country code | Fixed as 3 digits (Numerics) |
| ④ | eee --- eee: | Message data strings | 84 digits |
| ⑤ | fffffff: | Primary message data strings | 9 digits |
| ⑥ | ggg --- ggg: | Secondary message data strings | 84 digits |

- NOTES:**
1. When other than numerics is included in the data string of zip code (mode 2), zip code extension, class of service or country code, a MaxiCode is not drawn.
 2. If the message data is less than 84 digits when mode 2 or 3 is selected, the printer adds a CR (000000) at the end of the data, and the remaining digits will be padded with FSs (011100). When message data exceeding 84 digits is received, the excess data will be discarded before drawing a MaxiCode.
 3. If the message data is less than 93 digits (9 digits + 84 digits) when mode 4 or 6 is selected, the printer adds a CR (000000) at the end of the data, and the remaining digits will be padded with FSs (011100). When message data exceeding 93 digits is received, the excess data will be discarded before drawing a MaxiCode.
 4. Mode 6 should not be used for usual operation since it is used for scanner programming.

Examples

(1)

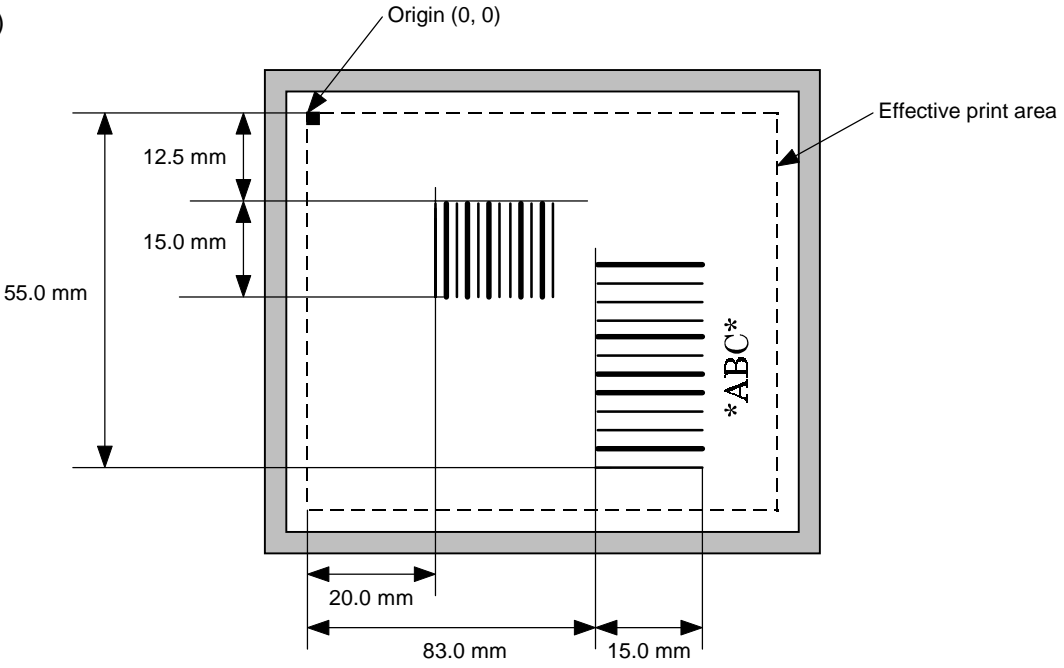

```
{C}
{XB01; 0200, 0125, 3, 1, 02, 02, 06, 06, 02, 0, 0150}
{XB02; 0830, 0550, 3, 1, 02, 04, 07, 08, 04, 3, 0150, +0000000000, 1, 00, N}
{RB01; 12345}
{RB02; *ABC*}
{XS; I, 0002, 0002C2000}
```

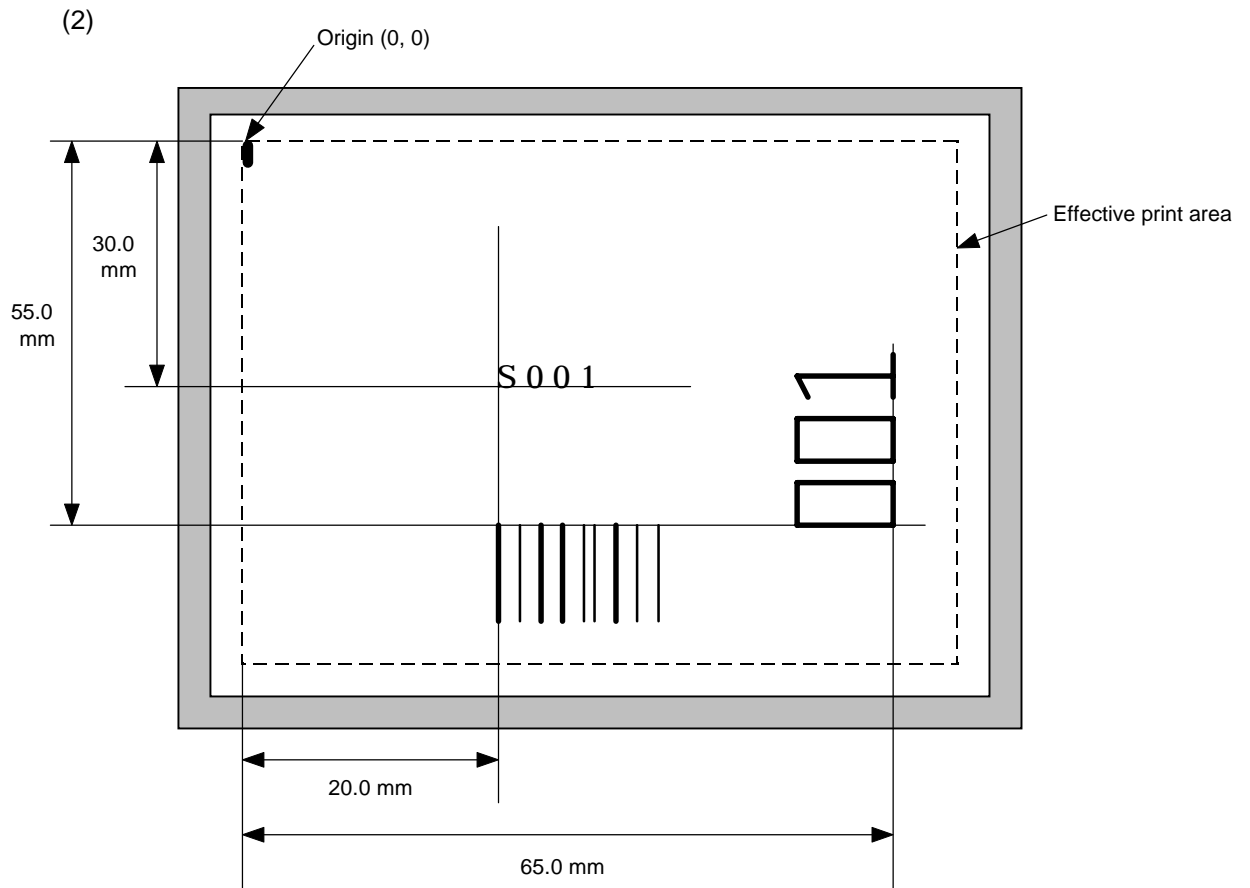

{C}

{PC001; 0200, 0300, 1, 1, C, 00, B; 01, 02}

{PV01; 0650, 0550, 0200, 0150, B, 33, B; 02}

{XB01; 0200, 0550, 3, 1, 02, 02, 06, 06, 02, 0, 0150; 01, 02}

{RB; S | 001}

{XS; I, 0002, 0002C2000}

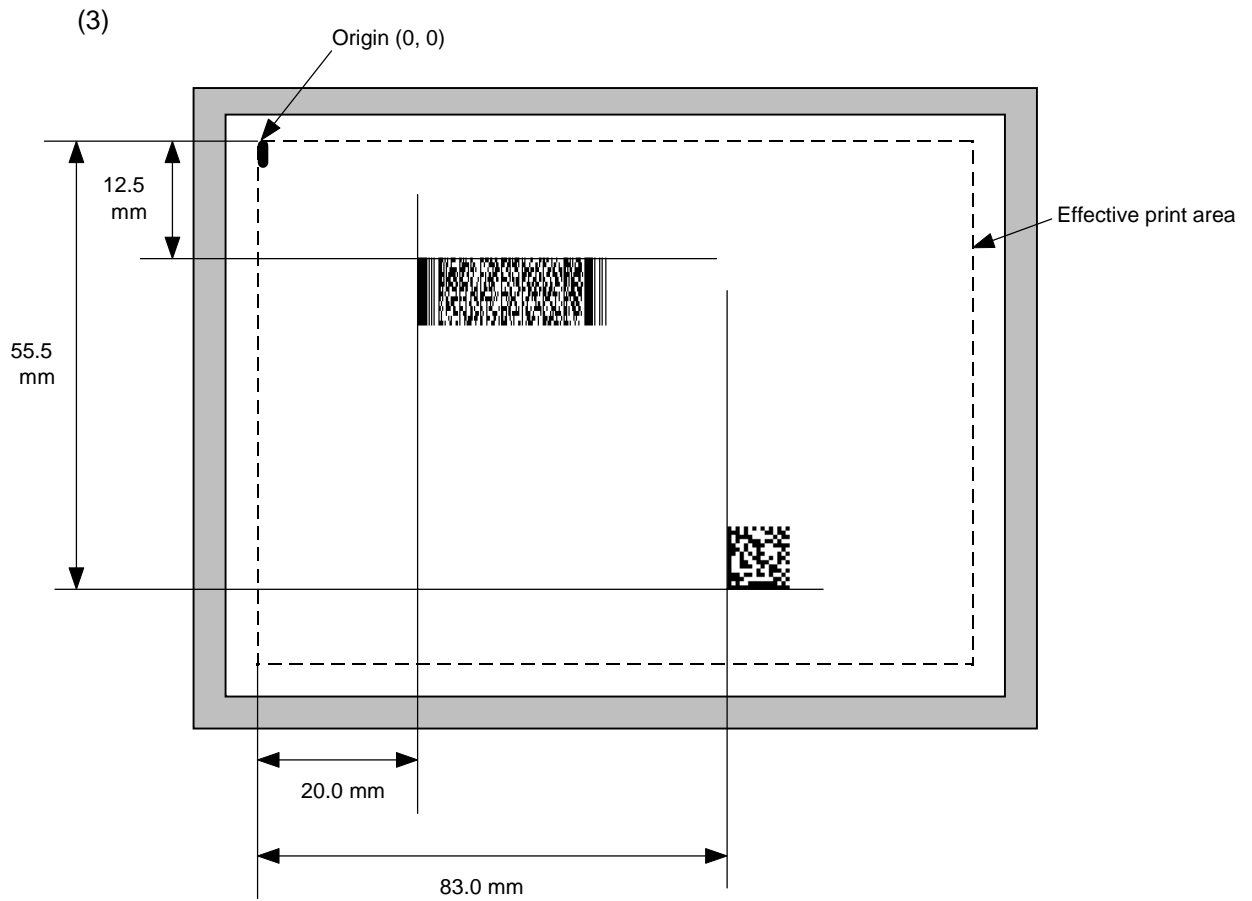

```

{C}
{XB01; 0200, 0125, P, 04, 02, 03, 0, 0010}
{XB02; 0830, 0550, Q, 08, 03, 05, 3}
{RB01; PDF417}
{RB02; Data Matrix}
{XS; I, 0002, 0002C2000}

```

6.16 ISSUE COMMAND

{XS

Function	Issues labels according to the print conditions programmed.
Format	{XS; I, aaaa, bbbcddefgh}
Term	<p>aaaa: Number of labels to be issued 0001 to 9999</p> <p>bbb: Cut interval. Designates the number of pieces to be printed before the backing paper is cut. 000 to 100 (no cut when 000)</p> <p>c: Type of sensor 0: No sensor 1: Reflective sensor 2: Transmissive sensor 3: Transmissive sensor (when using a manual threshold value) 4: Reflective sensor (when using a manual threshold value) If "5" is designated, it is recognized as "2".</p> <p>d: Issue mode C: Batch mode (cut issue, stop and cut, with back feed) D: Strip mode (with back feed)</p> <p>e: Issue speed 2: 50 mm/sec 4: 100 mm/sec</p> <p>f: With/without ribbon 0: Without ribbon 1: With ribbon If "2" is designated, it is recognized as "1".</p> <p>g: Designates tag rotation. 0: Printing bottom first 1: Printing top first 2: Mirror printing bottom first 3: Mirror printing top first</p> <p>h: Type of status response 0: No status response made 1: Status response made</p>

Explanation

(1) Number of labels to be issued

- ① If increment/decrement is not specified, the designated number of pieces with the same drawing data will be issued.
- ② If increment /decrement is specified, the designated number of pieces will be issued while incrementing/decrementing the piece of the designated drawing area.

* The increment/decrement designation is valid until the Image Buffer Clear Command ({C) is transmitted.

(2) Cut interval

The cut interval is valid only when the cutter has been installed and the issue mode is "C". If an error occurs during an issue after the cut interval is designated, and then printing is restarted, the printer ejects the printed paper then resumes printing on the paper where the error occurred.

(3) Type of sensor

① No sensor: Printing takes place according to the parameter designated by the Label Size Set Command.

② Reflective sensor:

Printing takes place according to the parameter designated by the Label Size Set Command. However, the black mark provided on the back side of the tag paper is automatically sensed by the reflective sensor and the paper position is finely adjusted for every piece.

③ Transmissive sensor

Printing takes place according to the parameter designated by the Label Size Set Command. However, the label-to-label gap is automatically sensed by the transmissive sensor and the paper position is finely adjusted for every piece.

④ Transmissive sensor (when using a manual threshold value)

Printing takes place according to the parameter designated by the Label Size Set Command. However, the label-to-label gap is automatically sensed by the transmissive sensor and the paper position is finely adjusted for every piece, according to the value set by the threshold setting operation (key operation).

⑤ Reflective sensor (when using a manual threshold value)

Printing takes place according to the parameters designated by the Label Size Set Command. However, the black mark provided on the back of the tag paper is automatically sensed by the reflective sensor and the paper position is finely adjusted for every piece, according to the value set by the threshold setting operation (key operation).

(4) Issue mode

[Batch mode (cut interval 0), with the automatic forward feed standby]

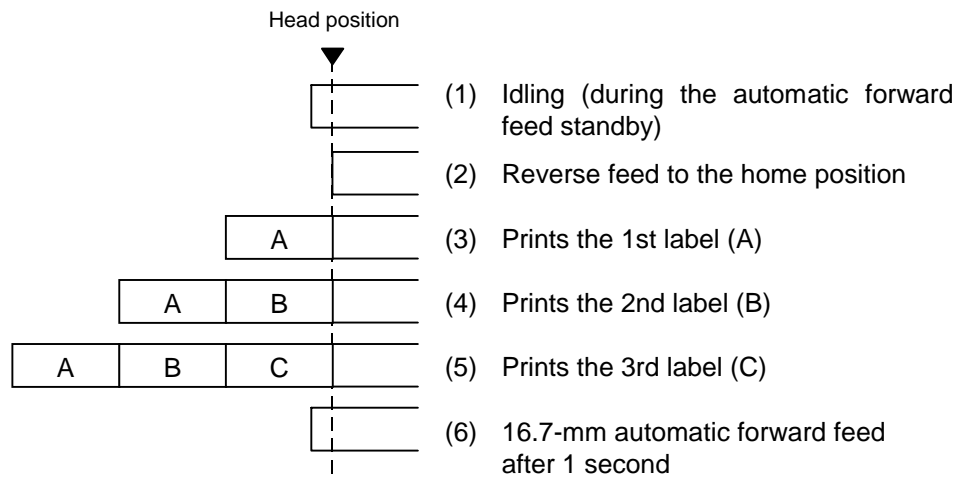

[Batch mode (cut interval 0), without the automatic forward feed standby]

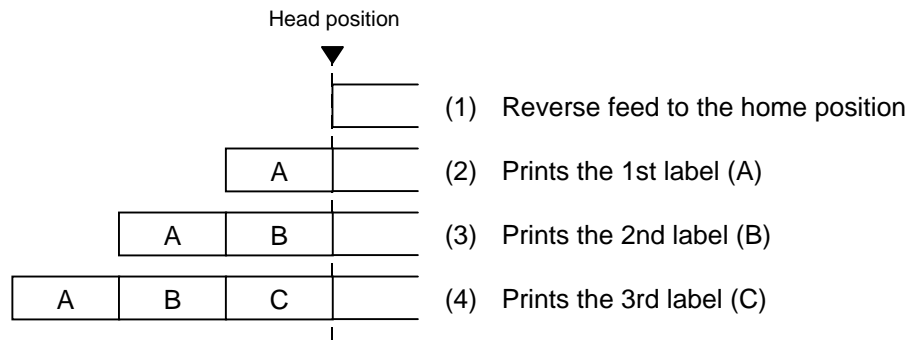

[Batch mode (cut interval 1, 2 labels to be issued, without the automatic forward feed standby)]

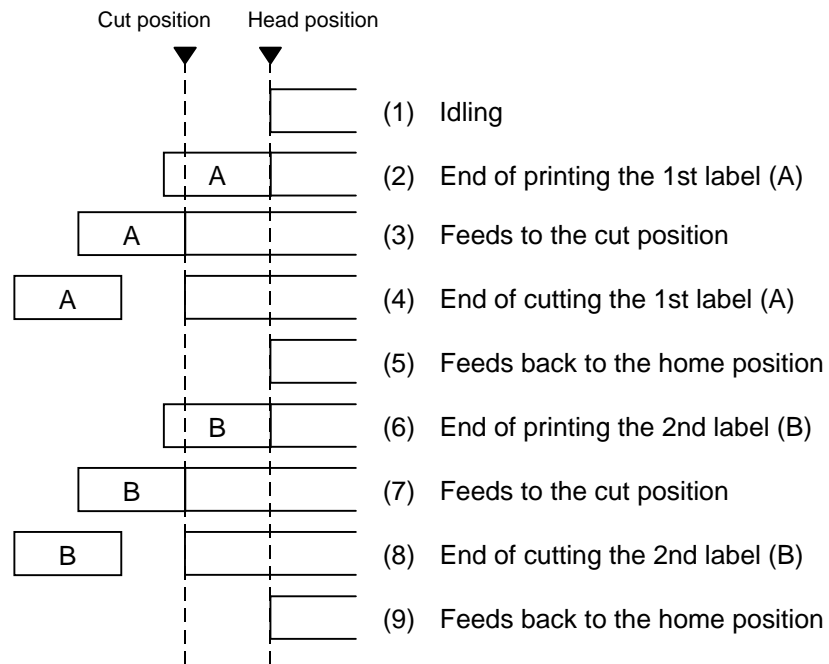

[Batch mode (cut interval 1, 2 labels to be issued, with the automatic forward feed standby)]

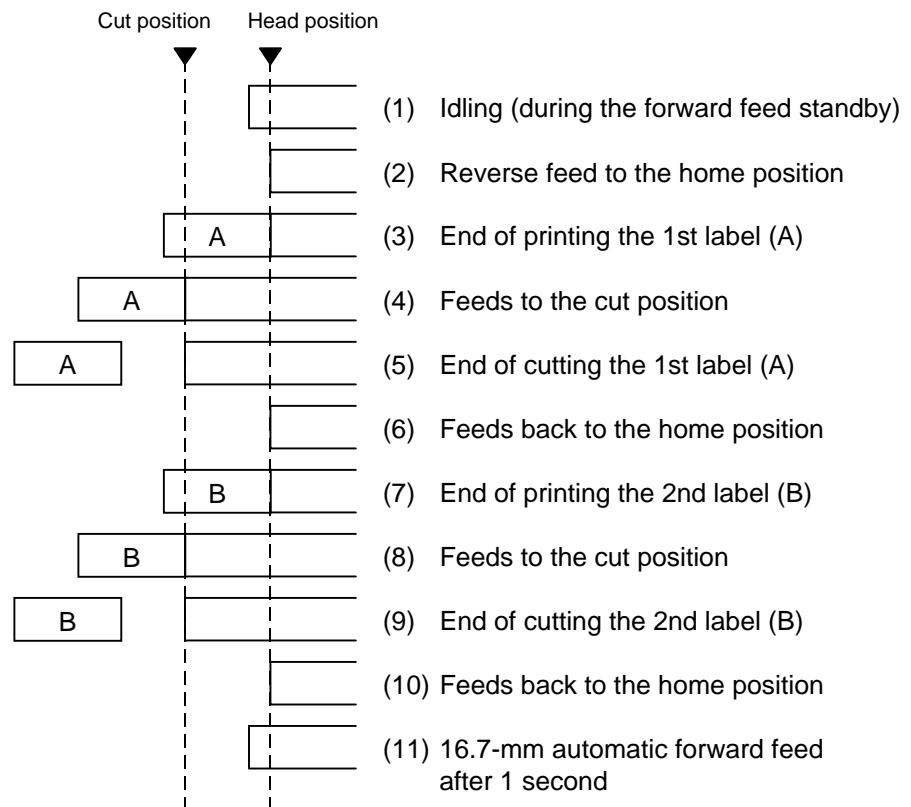

[Strip mode]

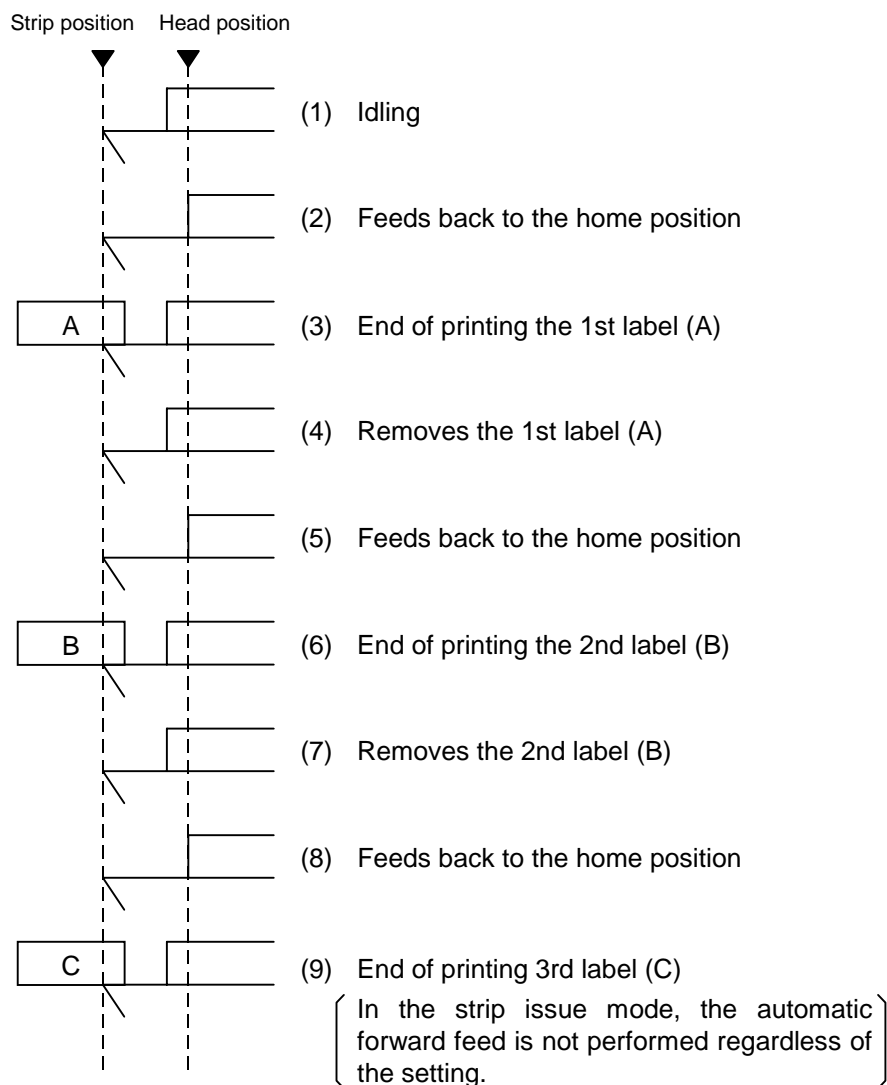

* The next label is not printed until the printed label is removed.

(5) Issue speed

- Printing takes place at the designated speed. However, the back feed speed should be 50 mm/sec.
- The possible issue speed varies according to types and sizes of supply. For details, refer to the Supply Specification.

Parameter	Issue speed
1	50 mm/sec
2	
3	
4	100 mm/sec
5	
6	
7	
8	
9	
A	

(6) With/without ribbon

Without ribbon : Use direct thermal paper.

With ribbon : Use thermal transfer ribbon.

(7) Tag rotation

The origin of coordinates and printing direction vary according to the designation of tag rotation.

① Printing bottom first

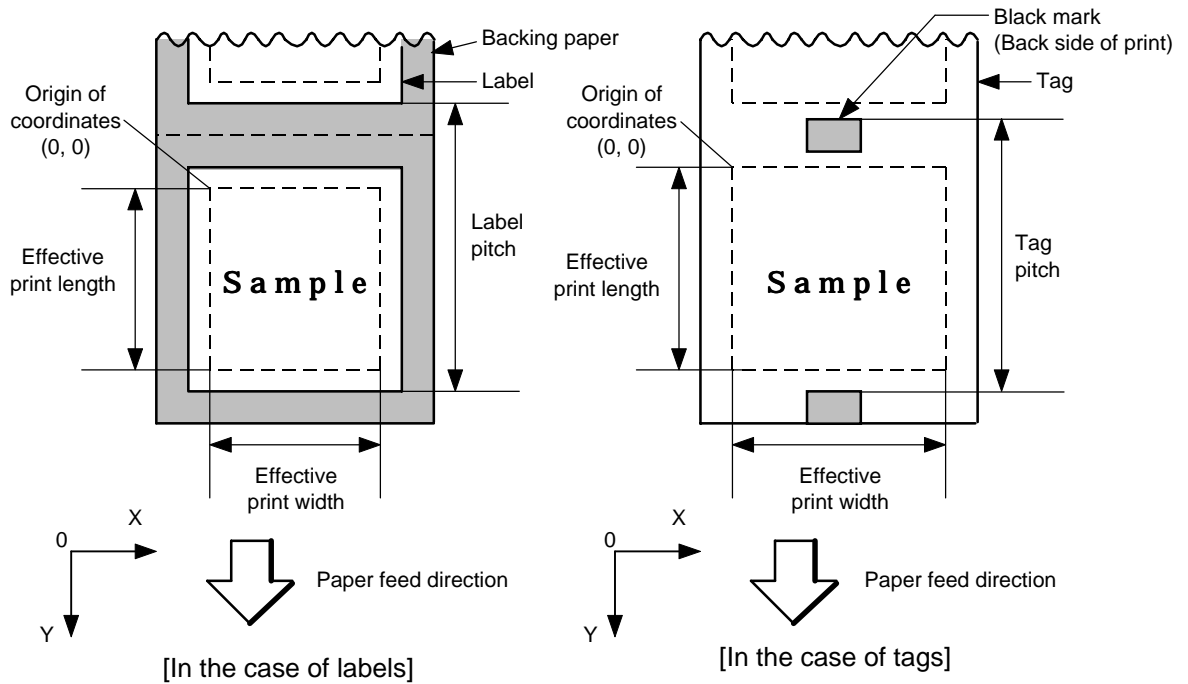

② Printing top first

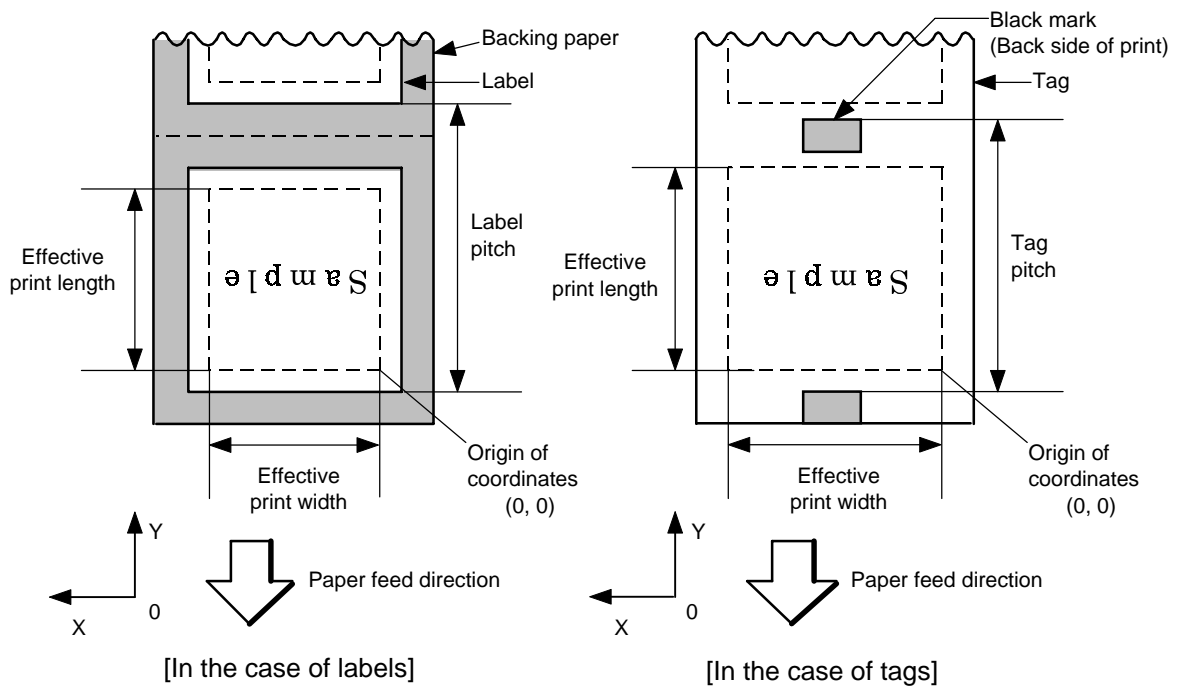

③ Mirror printing bottom first

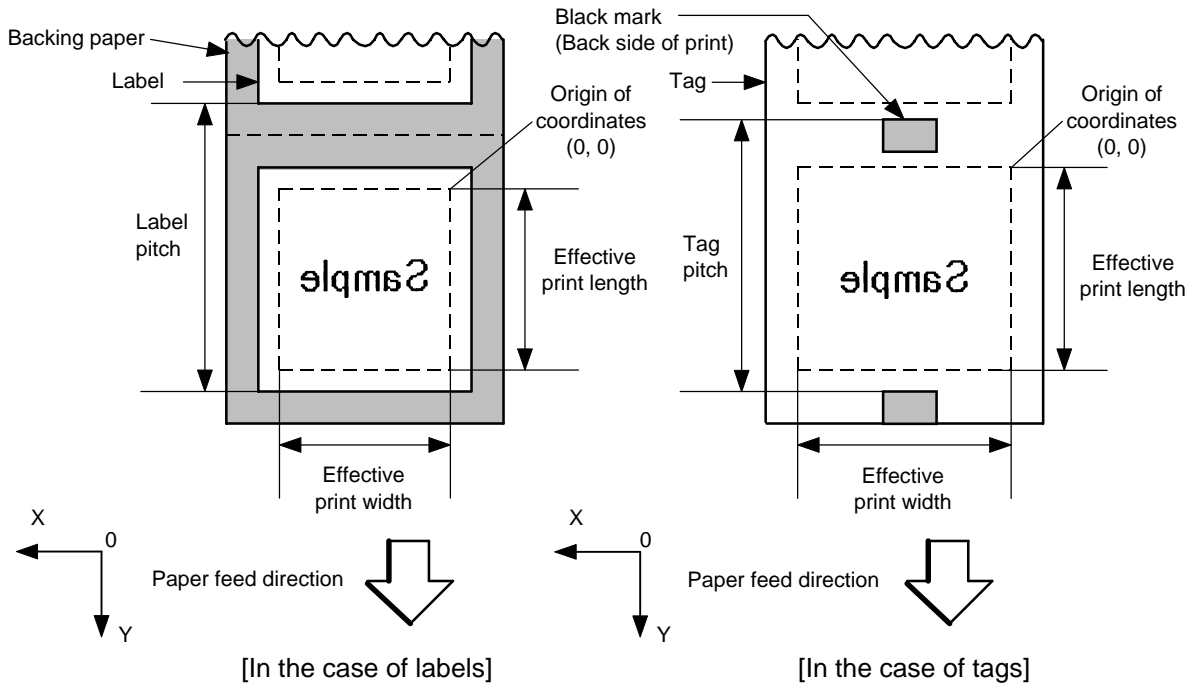

④ Mirror printing top first

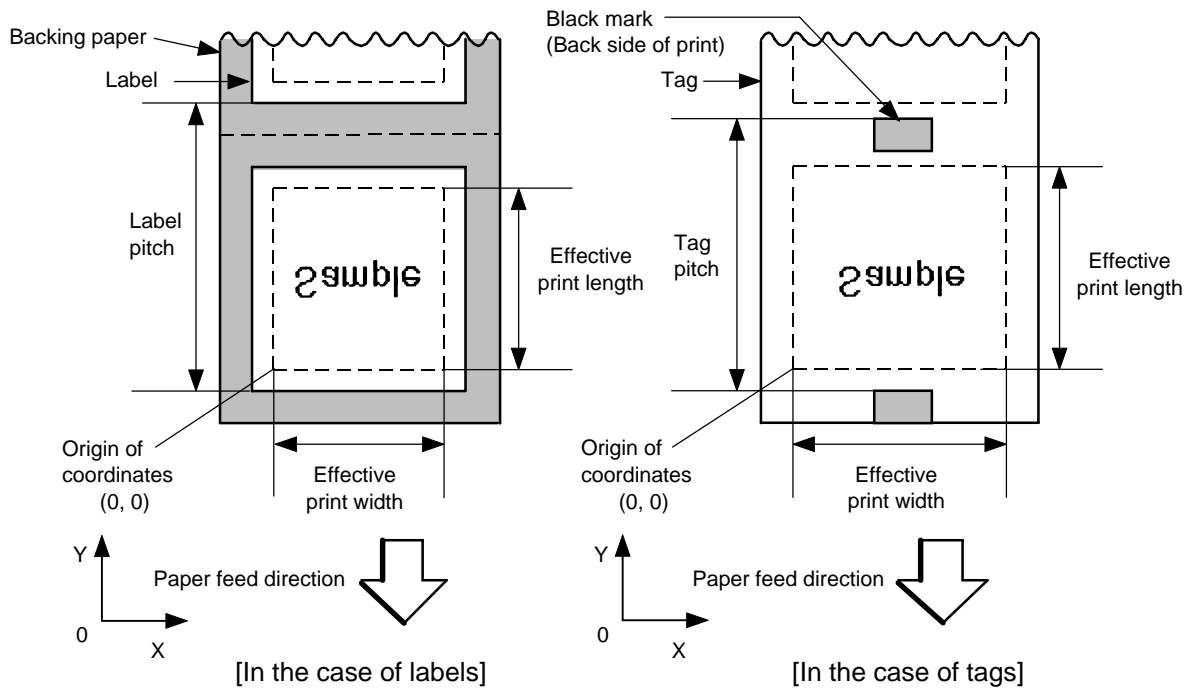

(8) Status response

When the option with status response has been selected, a status response is made at the end of printing or if an error occurs.

In the batch mode and cut mode, the print end status response is made after printing on the designated number of labels.

In the strip mode, the status response is made after printing one label.

* Do not change the parameter for status response/no status response during printing. Otherwise the status response may not be performed properly.

Examples

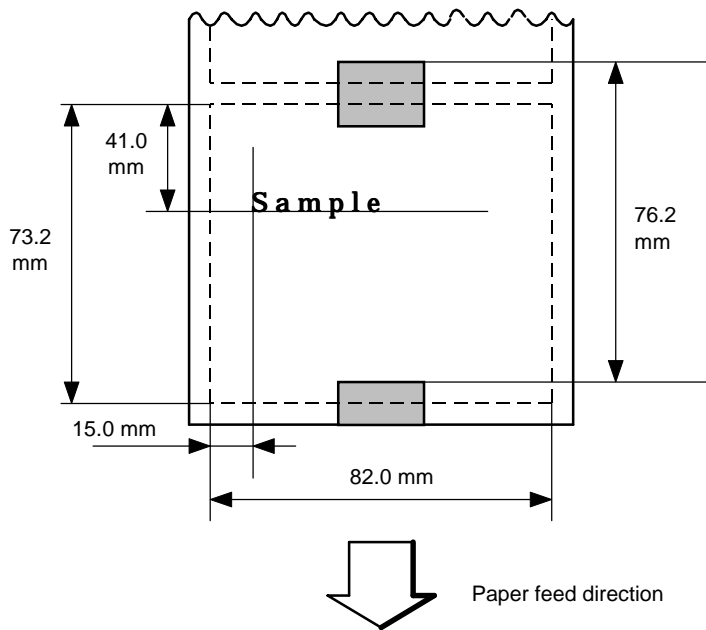

- Issue count: 4 pieces
- Cut interval: 1 piece
- Paper: Tag paper (Reflective sensor used)
- Issue mode: Cut issue
- Issue speed: 50 mm/sec
- Status response: On

```
{D0762, 0820, 0732}  
{T11C20}  
{C}  
{PC001; 0150, 0410, 1, 1, A, 00, B}  
{RC001; Sample}  
{XS; I, 0004, 0011C2001}
```

Notes

- ⊙ Explanation of processes involved to stop the label at the home position after the head open state is detected:

When the gap between labels (black mark) is found after the head open state is detected, the value to stop at the home position of each label between the head and the sensor is set again.

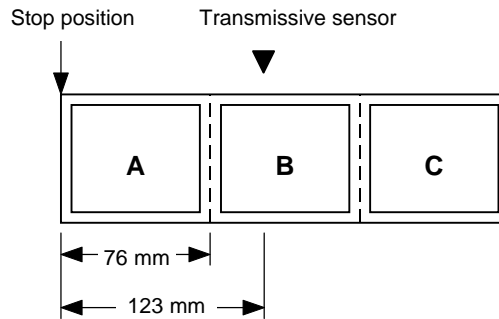

- The paper is moved in the above state.

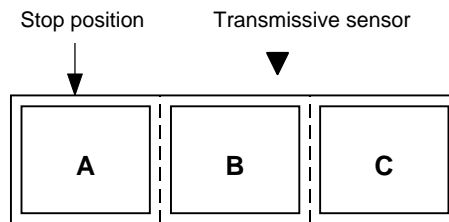

- Stop position after feeding one label

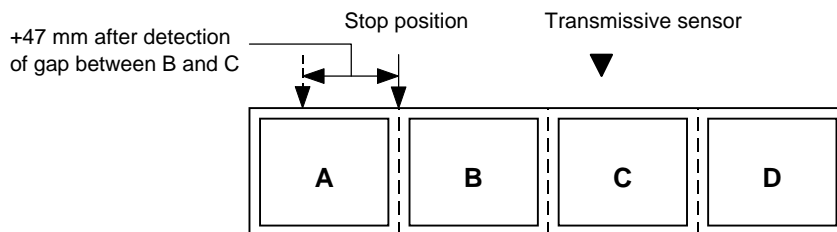

* However, an error will result when feed jam conditions are met.

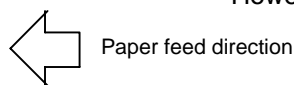

- ⊙ Automatic forward feed operation after a label is fed (effective only when the automatic forward feed standby is selected)

If the next command is not received from the PC within 1 second after the last label has been fed, the printer performs a 16.7-mm forward feed automatically. If the Issue Command is received during forward feed standby, the printer feeds the label in reverse to the home position, and then starts an issue.

If a feed is performed by using the [FEED] key on the printer when the power is turned off/on before the automatic forward feed, or after the printer is paused/reset, the automatic forward feed is not performed. After the automatic forward feed is performed, the power should be off/on, or the printer should be paused/reset. If a feed is performed by using the [FEED] key on the printer during forward feed standby, the printer feeds one label, performs the automatic forward feed, and then stops.

6.17 FEED COMMAND

{T

Function	Feeds the paper.
Format	{Tabcde}
Term	<p>a: Type of sensor 0: No sensor 1: Reflective sensor 2: Transmissive sensor 3: Transmissive sensor (when using a manual threshold value) 4: Reflective sensor (when using a manual threshold value) If "5" is designated, it is recognized as "2".</p> <p>b: Selects cut or non-cut 0: Non-cut 1: Cut</p> <p>c: Feed mode C: Batch mode (cut issue, stop and cut, with back feed) D: Strip mode (with back feed)</p> <p>d: Feed speed 2: 50 mm/sec 4: 100 mm/sec</p> <p>e: With/without ribbon 0: Without ribbon 1: With ribbon If "2" is designated, it is recognized as "1".</p>
Explanation	<p>(1) Type of sensor</p> <p>① No sensor: Feeding takes place according to the parameter designated by the Label Size Set Command.</p> <p>② Reflective sensor: Feeding takes place according to the parameter designated by the Label Size Set Command. However, the black mark provided on the back side of the tag paper is automatically sensed by the reflective sensor and the stop position is finely adjusted.</p> <p>③ Transmissive sensor: Feeding takes place according to the parameter designated by the Label Size Set Command. However, the label-to-label gap is automatically sensed by the transmissive sensor and the stop position is finely adjusted.</p> <p>④ Transmissive sensor (when using a manual threshold value): Feeding takes place according to the parameter designated by the Label Size Set Command. However, the label-to-label gap is automatically sensed by the transmissive sensor and the stop position is finely adjusted according to the value set by the threshold setting operation (key operation).</p> <p>⑤ Reflective sensor (when using a manual threshold value): Feeding takes place according to the parameters designated by the Label Size Set Command. However, the black mark provided on the back of the tag paper is automatically sensed by the reflective sensor and the stop position is finely adjusted according to the value set by the threshold setting operation (key operation).</p>

(2) Cut/non-cut

This option is valid in the batch feed mode only. (Non-cut is selected in the strip mode.)

(3) Feed mode

[Batch (non-cut), with the automatic forward feed standby]

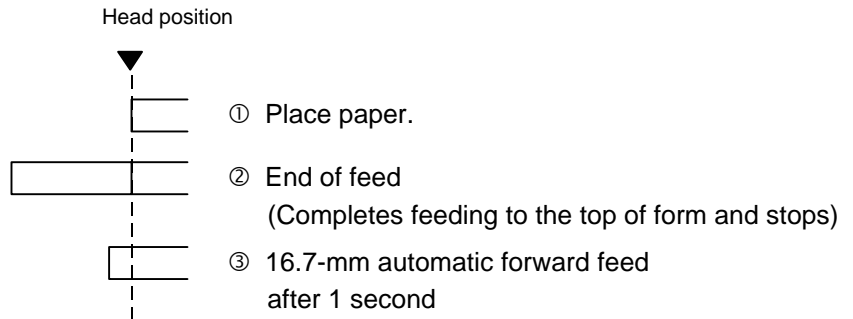

[Batch (non-cut), without the automatic forward feed standby]

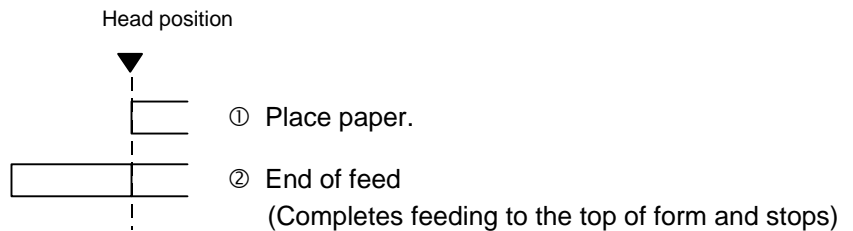

[Batch (cut), without the automatic forward feed standby]

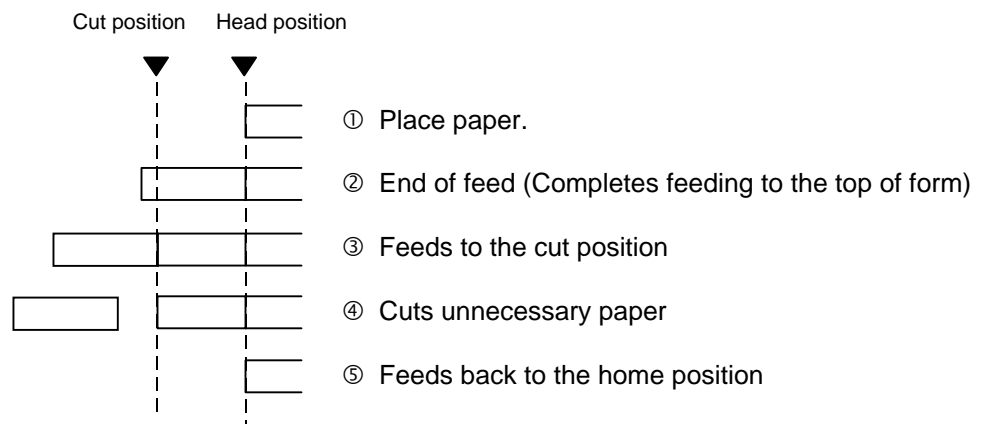

[Batch (cut), with the automatic forward feed standby]

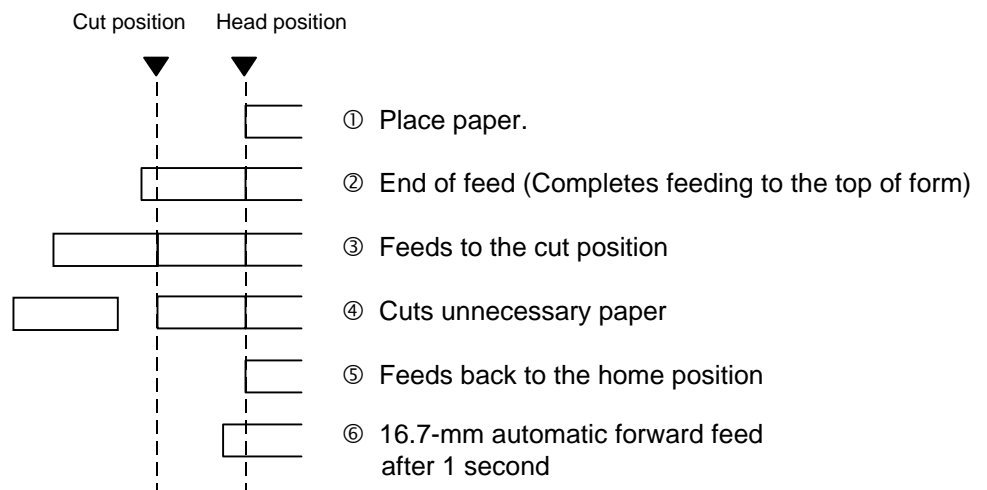

[Strip]

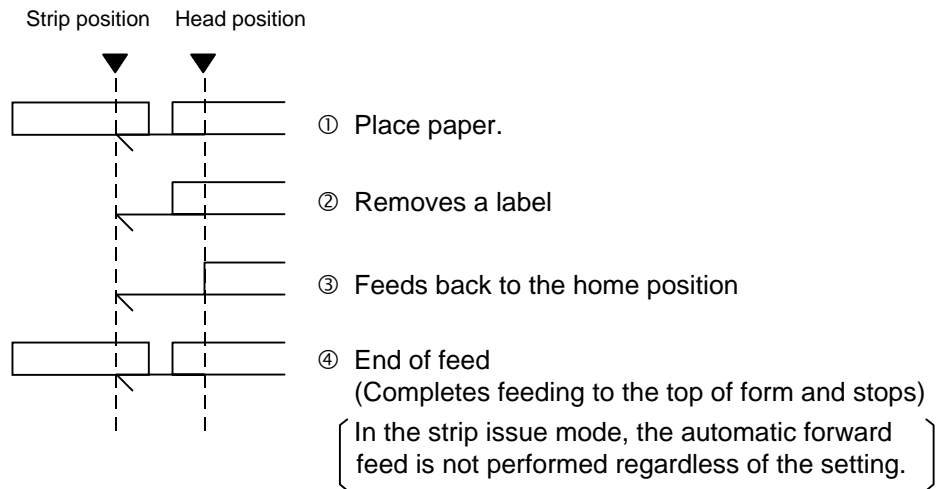

(4) Feed speed

- A feed is performed at the designated speed. However, the back feed speed should be 50 mm/sec.
- The possible feed speed varies according to types and sizes of supply. For details, refer to the Supply Specification.

Parameter	Issue speed
1	50 mm/sec
2	
3	
4	100 mm/sec
5	
6	
7	
8	
9	
A	

(5) With/without ribbon

- Without ribbon : The ribbon motor is not operated at feed.
 With ribbon : The ribbon motor is operated at feed.

Notes

- (1) If a change of label size or type of sensor, feed fine adjustment, cut position fine adjustment (or strip position fine adjustment) or back feed fine adjustment is made, one label must be fed to adjust the first printing position prior to printing.
- (2) The parameter of the Feed Command is protected in memory (even if the power is turned off).
- (3) When "status response made" is selected in the Feed Command, a status response is made after a feed is completed or when an error occurs.
- (4) For explanation about the processing to stop the label at the home position, refer to the section regarding the Issue Command.
- (5) If no subsequent command is received from the PC for 1 second after the last label has been fed, the printer automatically performs a 16.7-mm forward feed (effective only when the automatic forward feed standby mode is selected). If the Feed Command is received during the forward feed standby, the printer feeds the label in reverse to the original position and ejects it.
 * For notes, refer to the section regarding the Issue Command.

Examples

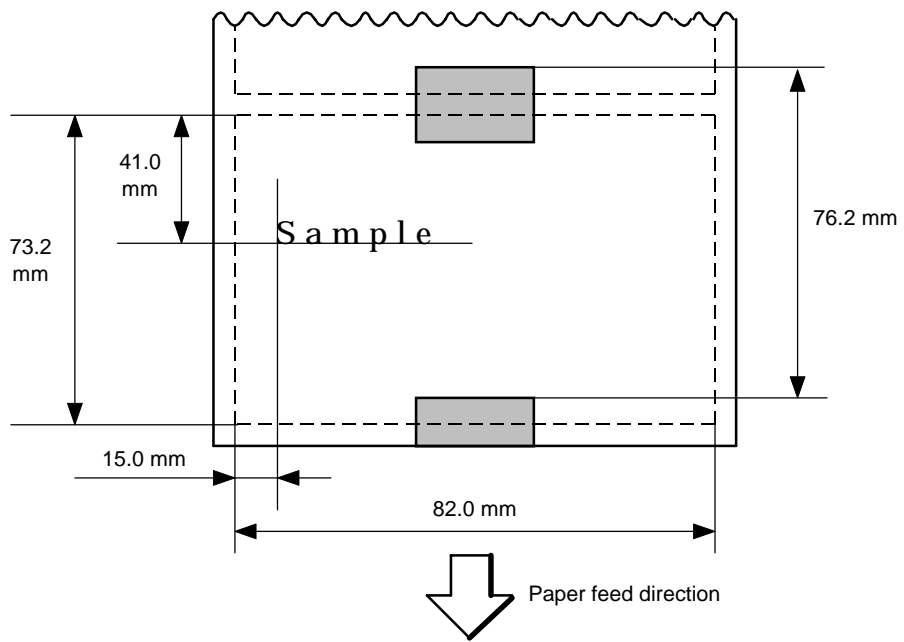

```
{D0762, 0820, 0732}  
{AX; +010, +000, +10}  
{T11C20}  
{C}  
{PC001; 0150, 0410, 1, 1, A, 00, B}  
{RC001; Sample}  
{XS; I, 0004, 0011C2001}
```

6.18 EJECT COMMAND

{IB}

Function Ejects (Cuts) the label presently remaining between the head and the cutter and returns to the original position.

Format {IB}

Notes If no subsequent command is received from the PC for 1 second after ejection, the printer automatically performs a 16.7-mm forward feed (effective only when the automatic forward feed standby mode is selected).

When the Eject Command is received in the forward feed standby state, the printer feeds the label in reverse to the original position and ejects it.

* For notes, refer to the section regarding the Issue Command.

Examples [With the automatic forward feed standby]

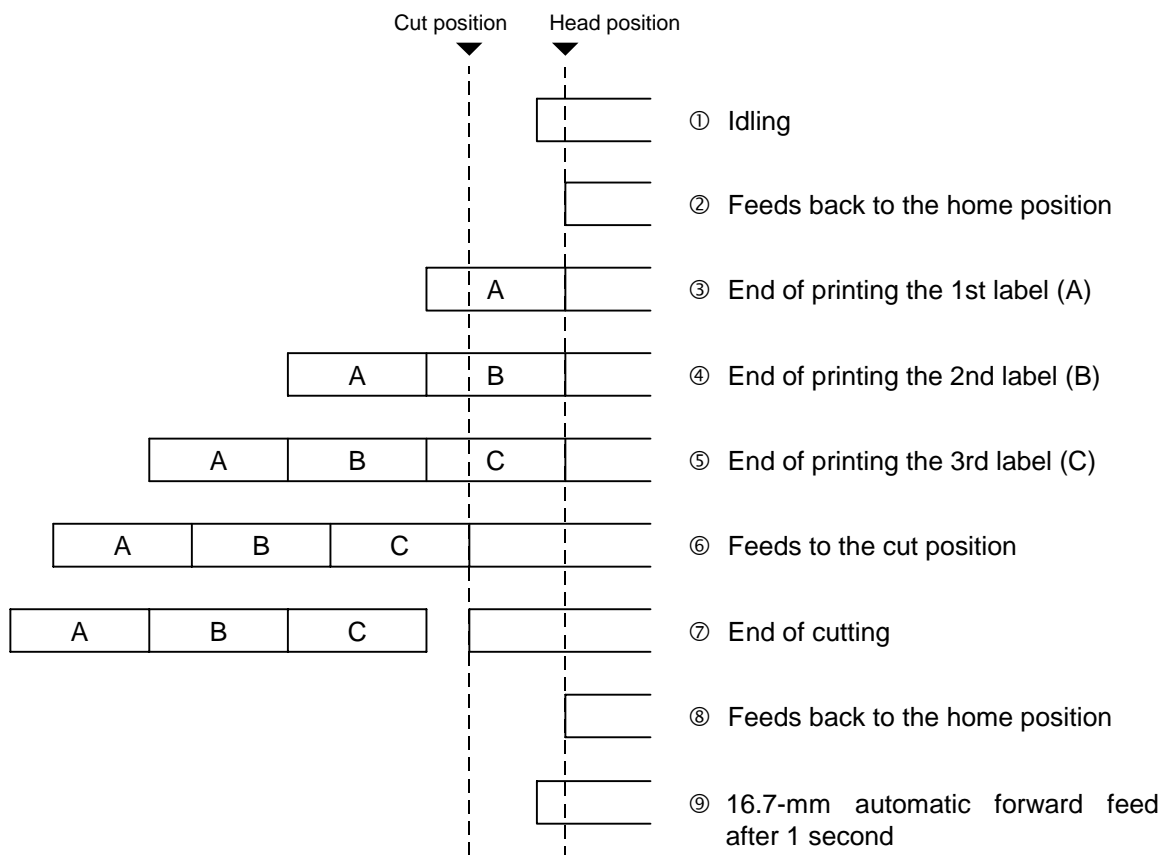

[Without the automatic forward feed standby]

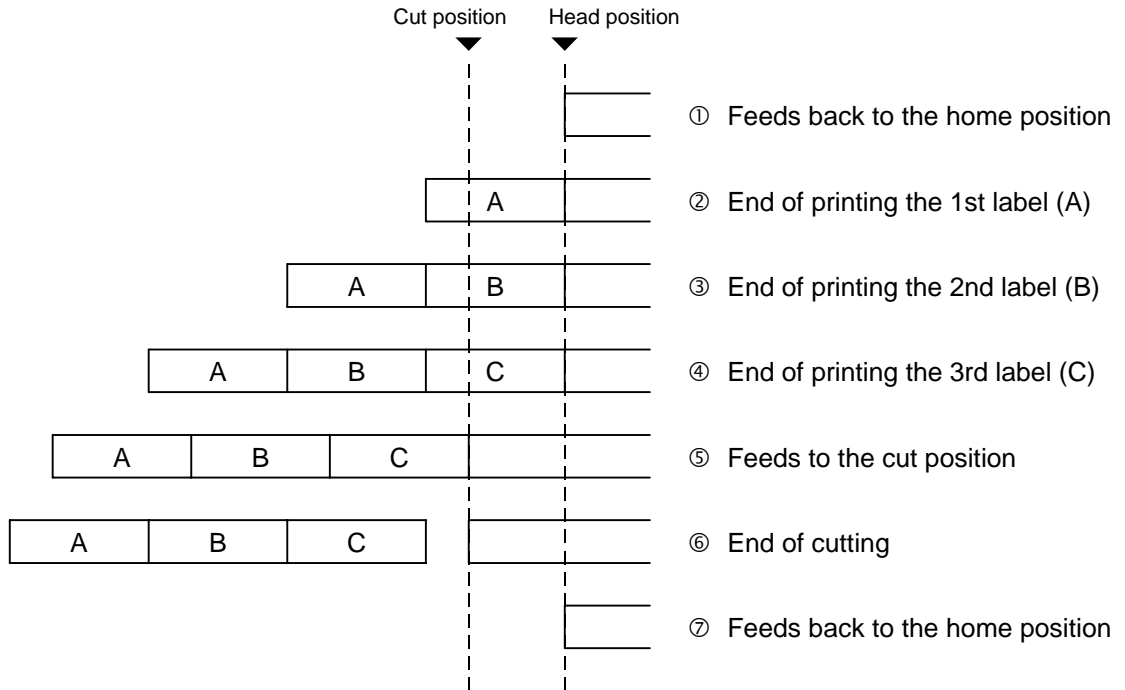

```
{C}  
{PC001; 0200, 0125, 1, 1, A, 00, B}  
{RC001; A}  
{XS; I, 0001, 0001C2001}  
{RC001; B}  
{XS; I, 0001, 0001C2001}  
{RC001; C}  
{XS; I, 0001, 0001C2001}  
{IB}
```

6.19 FORWARD/REVERSE FEED COMMAND

{U1, {U2

Function	After printing or feeding the paper, feeds the paper to the position at which the paper can be cut manually. When issuing the next label, feeds the paper back to the first printing position.
Format	Forward Feed {U1; aaaa} Reverse Feed {U2; aaaa}
Term	aaaa: Feed length by which the paper is fed forward or backward. 0030 to 0330 (in 0.1 mm units)
Notes	<ol style="list-style-type: none">(1) When the [FEED] key on the printer is pressed, one label is fed, and then fed by the forward feed value automatically if the Forward Feed Command has already been transmitted.(2) The Forward/Reverse Feed Command is protected in memory (even if the power is turned off).(3) The Forward/Reverse Feed Command is ignored in the strip mode and cut issue mode.(4) The forward/reverse feed is performed at the speed designated in the Issue Command or Feed Command. However, the reverse feed speed should be 50 mm/sec.(5) The Forward/Reverse Feed Command is ignored when the automatic forward feed standby mode is selected.

Examples

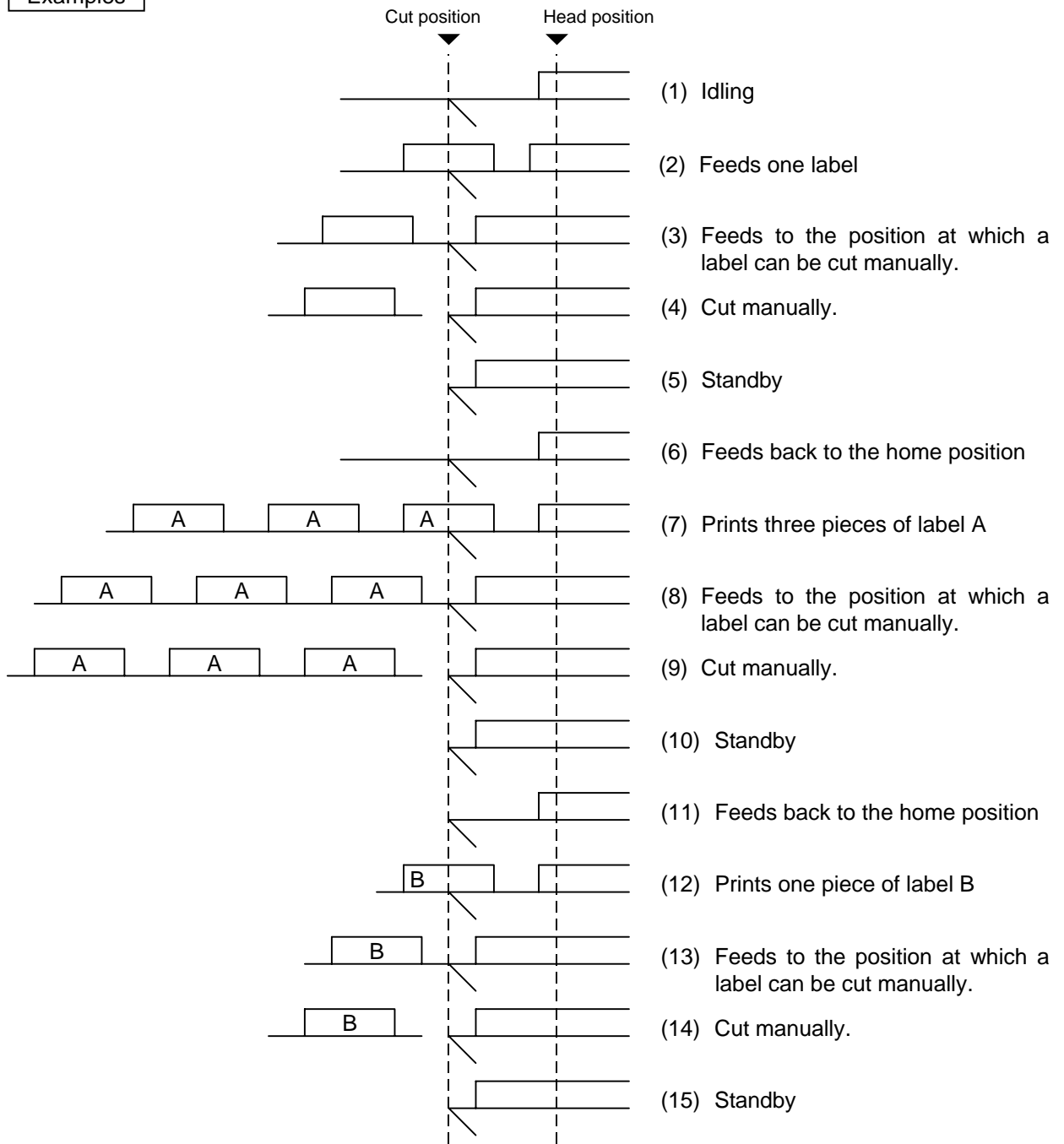

```
{T20C20}
{U1; 0120}
  Cut manually.
{U2; 0120}
{RC001; A}
{XS; I, 0003, 0002C2001}
{U1; 0120}
  Cut manually.
{U2; 0120}
{RC001; B}
{XS; I, 0001, 0002C2001}
{U1; 0120}
```

6.20 FORMAT COMMAND

{J1

Function	Formats (Initializes) the flash memory.
Format	{J1; a (b)}
Term	a: Formatting (initializing) range A: The PC save area and writable character area of flash memory B: PC save area of flash memory C: Writable character area of flash memory b: Flash memory capacity (If omitted, "2-MB installed" is selected.) 0: 1-MB flash memory installed 1: 2-MB flash memory installed
Explanation	(1) The flash memory can be roughly divided into the PC save area and writable character area. They can be formatted (initialized) either separately or at the same time. (2) After formatting, the remaining memory is as follows: PC save area: 7 Kbytes Writable character area: 1-MB flash memory installed: 48 KB 2-MB flash memory installed: 960 KB (3) When storing already stored data (PC save, writable characters, logos) again, memory is consumed with every storing unless the Format Command ({J1}) is transmitted. (4) When performing the label issue operation after sending the Format Command, the image buffer is automatically cleared. (5) When the storing of writable characters, logos, or PC interface commands stops, the printer automatically enters the online mode (label issue operation) after about 10 seconds. In this case, the image buffer is automatically cleared.
Refer to	<ul style="list-style-type: none">• Bit Map Writable Character Command ({XD})• Save Start Command ({XO})• Save Terminate Command ({XP})
Example	{J1; A1}

6.21 2-BYTE WRITABLE CHARACTER CODE RANGE COMMAND {XE}

Function Sets the code range when a 2-byte writable character code is stored.

Format {XE; a₁a₁a₁a₁, b₁b₁b₁b₁, a₂a₂a₂a₂, b₂b₂b₂b₂ -----, a_na_na_na_n, b_nb_nb_nb_n}

Term

aaaa: First character code for each range
2020 to FFFF (Hex.)

bbbb: No. of characters for each range
0001 to 4000 (Hex.)

Explanation

- (1) For a 2-byte character code such as Kanji, the character code range may be divided into two or more. The control information area for the unnecessary code can be deleted by designating the character code range, and the capacity of the flash memory is not wasted.
- (2) This command is effective when the 2-MB flash memory installed is formatted for the writable character area.
- (3) Up to 2700 can be designated for the range.
- (4) A character code which is not appropriate for the setting for this command cannot be stored.

Refer to

- Format Command ({J1})
- Bit Map Writable Character Command ({XD})
- Save Start Command ({XO})

Example In the case that Shift JIS 8140H to 83DFH: Character data exists.
 Character data does not exist.

	0	1	2	3	4	5	6	7	8	9	A	B	C	D	E	F
8140																
81F0																
8240																
82F0																
8340																
83D0																

{XE; 8140, 00C0, 8240, 00C0, 8340, 00A0}

6.22 BIT MAP WRITABLE CHARACTER COMMAND {XD}

Function Writes writable characters and logos in the flash memory.

Format {XD; aa, b, ccc, ddd, eee, fff, ggg, h, iii ----- iii}

Term aa: Writable character set

1-MB ROM installed	2-MB ROM installed
01 to 10	01 to 40
	41 16 × 16 (dots)
	42 24 × 24 (dots)
	43 32 × 32 (dots)
	44 48 × 48 (dots)
	51 (2-byte character code)

b(b): Writable character code
 20H to FFH (Set in hex.)
 40H to 7EH, 80H to FCH (when the writable character set is 41 to 44)
 2020H to FFFFH (when the writable character set is 51)

ccc: Left offset
 000 to 719 (in dots)

ddd: Top offset
 000 to 719 (in dots)

eee: Character width
 001 to 720 (in dots)

fff: Character height
 001 to 720 (in dots)

ggg: Horizontal spacing/proportional spacing
 000 to 999 (in dots)

h: Type of writable character data
 0: Nibble mode (4 bits/byte)
 1: Hex. mode (8 bits/byte)

iii ----- iii: Writable character data to be stored

* When the writable character set is 41 to 44, designation of left offset, top offset, character width, character height and horizontal spacing/proportional spacing is fixed as 000. If designated, they are ignored.

Explanation (1) Type of writable character

Up to 45 writable character sets (up to 10 for the model with 1-MB ROM) can be stored. However, the maximum number of characters varies depending on the writable character size and number of characters because of the limited memory capacity. For 41 to 44 writable character sets, each writable character size is fixed.

(2) Character code (Writable character set: 01 to 44)

Up to 224 characters can be stored per character set. The maximum number of characters is 44 sets × 224 characters = 9856 characters. It varies depending on the writable character size and number of characters because of the limited memory capacity.

For 41 to 44 character sets, the character code comprises 1 byte. However, when the character code is called, it is added F0H to the above digit, and comprises of 2 bytes. Up to 188 characters can be stored per character set.

(3) 2-byte writable character code (Writable character set: 51)

Up to 29120 characters can be stored. The max. number of storable characters varies depending on the writable character size, the number of characters, and non-sequence of the character code.

(4)

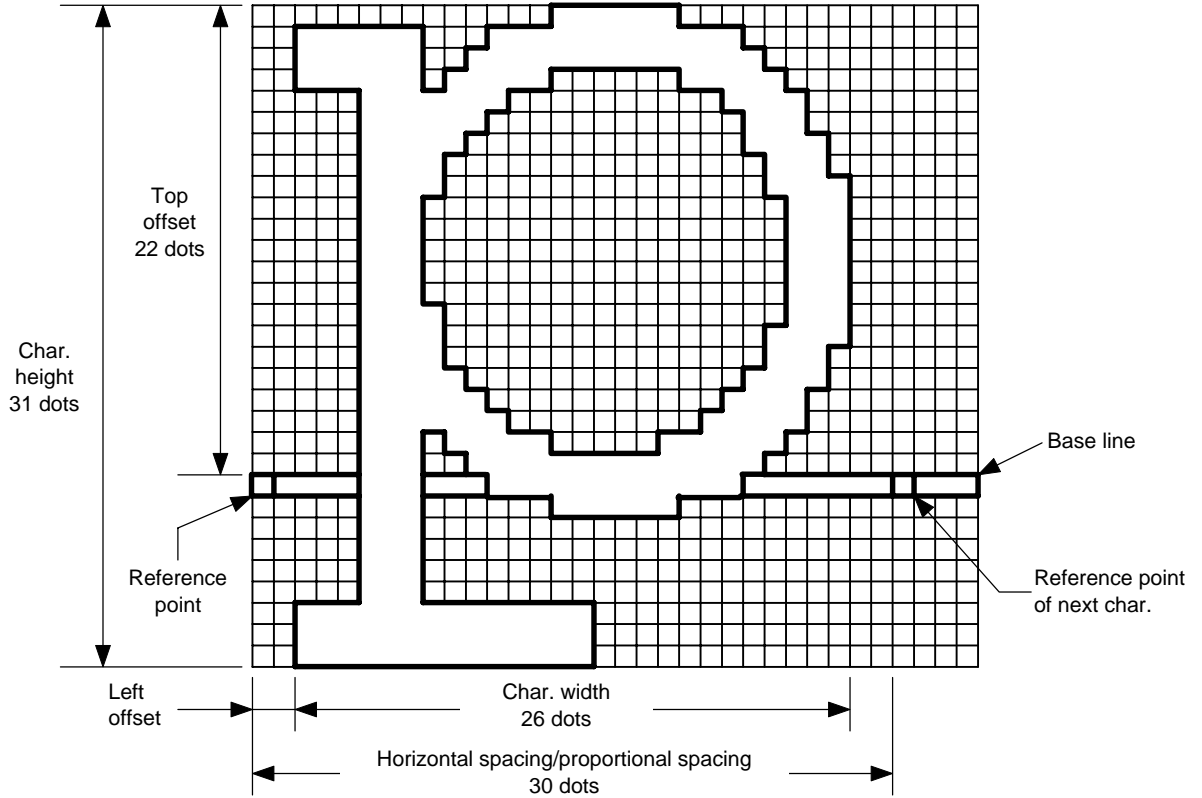

(5) Writable character set: 01 to 40, 51

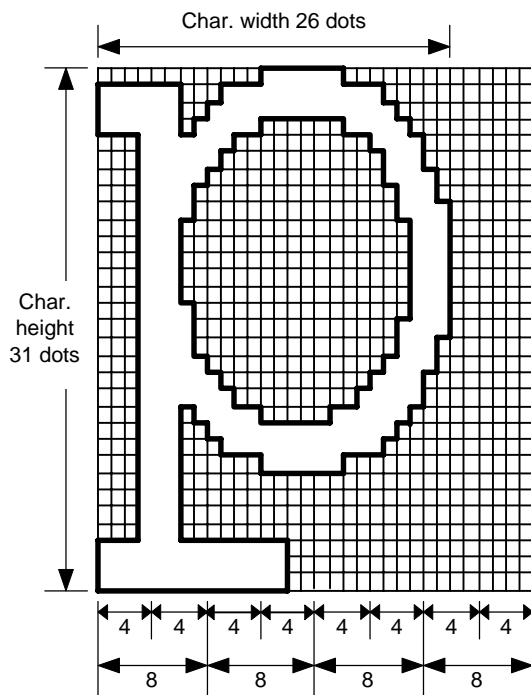

Nibble mode															
1	30H	2	30H	3	30H	4	3FH	5	3CH	6	30H	7	30H	8	30H
9	3FH	10	3CH	11	37H										
															240 30H
241	3FH	242	3FH	243	3FH	244	3CH	245	30H	246	30H	247	30H	248	30H

Hex. mode			
1	00H	2	0FH
3	C0H	4	00H
5	FCH	6	7FH
			120 00H
241	FFH	242	FCH
243	00H	244	00H

[Nibble mode]

- (1) The writable character data to be stored is separated into four dot units and sent in the following order (1 → 248). (High order digit: “3”)
- (2) The data of writable characters to be stored is 30H to 3FH.
- (3) The minimum unit in the X direction is 8 dots. Dots with no data are transmitted as data 0.
- (4) The data count of writable characters to be stored must be as follows:
 Data count of writable characters to be stored =
 $\{(No. of char. width dots + 7)/8\} \times No. of char. height dots \times 2$
 * The value in the brackets is rounded down to the nearest whole number.

[Hex. mode]

- (1) The writable character data to be stored is separated into eight dot units and sent in the following order (1 → 124).
- (2) The data of writable characters to be stored is 00H to FFH.
- (3) The minimum unit in the X direction is 8 dots. Dots with no data are transmitted as data 0.
- (4) The data count of writable characters to be stored must be as follows:
 Data count of writable characters to be stored =
 $\{(No. of char. width dots + 7)/8\} \times No. of char. height dots$
 * The value in the brackets is rounded down to the nearest whole number.

Notes

- (1) With the same writable character set designated, character width and character height can be designated for each writable character code. In other words, character size can be changed for each character, thus saving memory.
- (2) Proportional spacing and descending of characters are possible according to the parameters of horizontal spacing/proportional spacing, left offset, and top offset.
- (3) When top offset = 000, the reference coordinates are at the above left in drawing because the base line is at the top. (Coordinate setting is facilitated for logo.)

(6) Writable character set: 41 (16x16 dots)

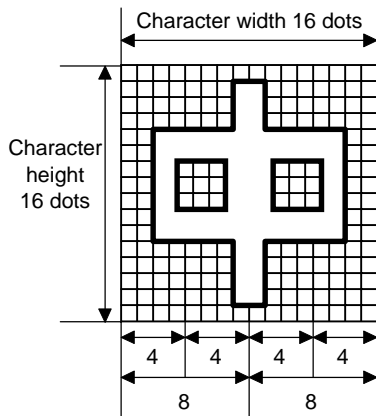

Nibble mode			
1	30H	2	30H
3	30H	4	30H
5	30H	6	31H
		7	38H
			•
			•
			•
		58	31H
		59	38H
		60	30H
61	30H	62	30H
		63	30H
		64	30H

Hex. mode			
1	00H	2	00H
3	01H	4	80H
5	01H	6	80H
		7	01H
			•
			•
			•
		26	80H
		27	01H
		28	80H
29	01H	30	80H
		31	00H
		32	00H

[Nibble mode]

- (1) The writable character data to be stored is separated into four dot units and sent in the following order (**1** → **64**). (High order digit: "3")
- (2) The data of writable characters to be stored is 30H to 3FH.
- (3) The data count of writable characters to be stored should be 64 bytes.

[Hex. mode]

- (1) The writable character data to be stored is separated into eight dot units and sent in the following order (**1** → **32**).
- (2) The data of writable characters to be stored is 00H to FFH.
- (3) The data count of writable characters to be stored should be 32 bytes.

* When writable character 41 is designated, the width and height of the character are both 16 dots.

(7) Writable character set: 42 (24×24 dots)

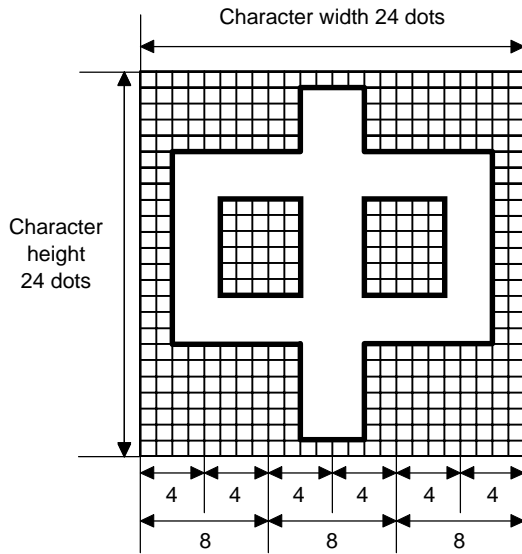

Nibble mode											
1	30H	2	30H	3	30H	4	30H	5	30H	6	30H
7	30H	8	30H	9	33H						
										137	30H
										138	30H
139	30H	140	30H	141	30H	142	30H	143	30H	144	30H

Hex. mode					
1	00H	2	00H	3	00H
4	00H	5	3CH	6	00H
67	00H	68	3CH	69	00H
70	00H	71	00H	72	00H

[Nibble mode]

- (1) The writable character data to be stored is separated into four dot units and sent in the following order (**1** → **144**). (High order digit: "3")
- (2) The data of writable characters to be stored is 30H to 3FH.
- (3) The data count of writable characters to be stored should be 144 bytes.

[Hex. mode]

- (1) The writable character data to be stored is separated into eight dot units and sent in the following order (**1** → **72**).
- (2) The data of writable characters to be stored is 00H to FFH.
- (3) The data count of writable characters to be stored should be 72 bytes.

* When writable character 42 is designated, the width and height of the character are both 24 dots.

(8) Writable character set: 43 (32×32 dots)

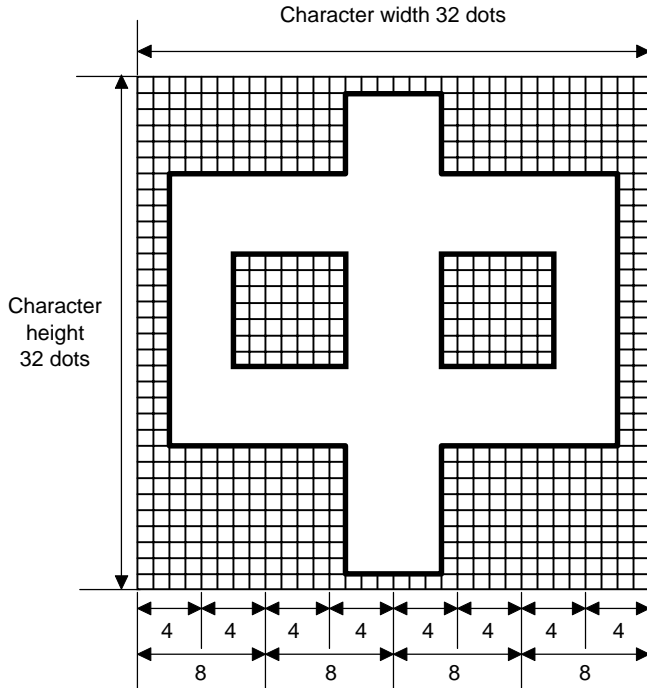

Nibble mode													
1	30H	2	30H	3	30H	4	30H	5	30H	6	30H	7	30H
8	30H	9	30H	10	30H	11	30H	12	37H				
•													
•													
•													
•													
•													
										248	30H	249	30H
250	30H	251	30H	252	30H	253	30H	254	30H	255	30H	256	30H

Hex. mode									
1	00H	2	00H	3	00H	4	00H		
5	00H	6	07H	7	C0H				
•									
•									
•									
•									
						123	C0H	124	00H
125	00H	126	00H	127	00H	128	00H		

[Nibble mode]

- (1) The writable character data to be stored is separated into four dot units and sent in the following order (1 → 256). (High order digit: "3")
- (2) The data of writable characters to be stored is 30H to 3FH.
- (3) The data count of writable characters to be stored should be 256 bytes.

[Hex. mode]

- (1) The writable character data to be stored is separated into eight dot units and sent in the following order (1 → 128).
- (2) The data of writable characters to be stored is 00H to FFH.
- (3) The data count of writable characters to be stored should be 128 bytes.

* When writable character 43 is designated, the width and height of the character are both 32 dots.

(9) Writable character set: 44 (48×48 dots)

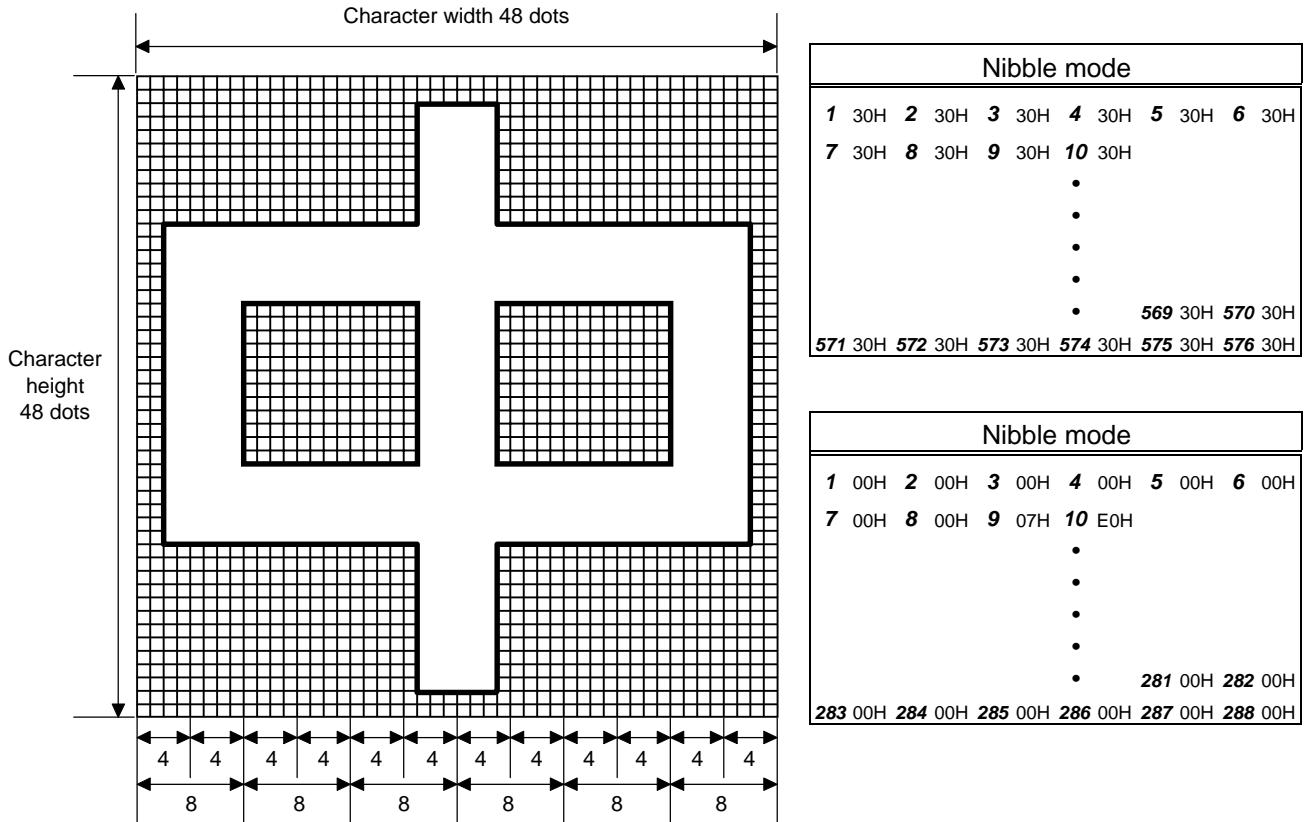

[Nibble mode]

- (1) The writable character data to be stored is separated into four dot units and sent in the following order (**1** → **576**). (High order digit: "3")
- (2) The data of writable characters to be stored is 30H to 3FH.
- (3) The data count of writable characters to be stored should be 576 bytes.

[Hex. mode]

- (1) The writable character data to be stored is separated into eight dot units and sent in the following order (**1** → **288**).
- (2) The data of writable characters to be stored is 00H to FFH.
- (3) The data count of writable characters to be stored should be 288 bytes.

* When writable character 44 is designated, the width and height of the character are both 48 dots.

Notes

- (1) No matter what character set or character code is selected, no memory will be wasted.
- (2) When a new writable character is stored, the Format Command ({J1}) must be transmitted. The remaining memory capacity after formatting is 960 KB of the writable character area. (48 Kbytes for the model with the 1-MB flash memory.)
- (3) An already stored character code can be stored again if the Writable Character Command ({XD}) is transmitted, but memory will be consumed with every storage. Memory can be efficiently used by sending the Format Command ({J1}) before storing.
- (4) When performing the label issue operation after sending the Bit Map Writable Character Command ({XD}), the image buffer is cleared automatically.
- (5) When the storing operation stops after storing the writable character and logos, the printer automatically enters the online mode (label issue operation) after about 10 seconds. In this case, the image buffer will be cleared automatically.

Refer to

Format Command ({J1})

Examples

Writable character set: 03
 Writable character code: 70H

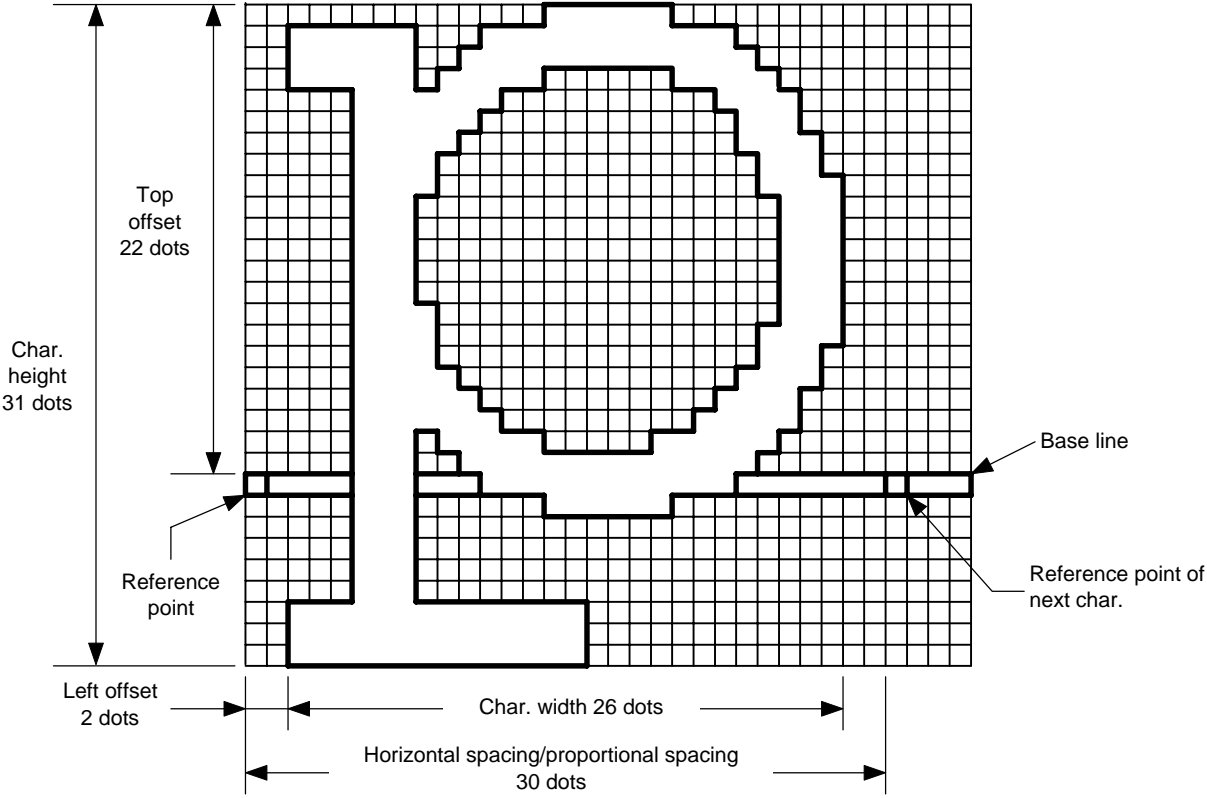

```
{J1; C|}
{XD; 03, p, 002, 022, 026, 031, 030, 0, 000?<000?<???800?<???<00?=?03>001?
<00?001?8007001?0007801>0003801>0003<01<0001<01<0001<01<0001<01<0001<01<0001<01>0
001<01>0003<01>0003801?0007801?800?001?<01?001=?07>001<???<001<???8001<0?<
0001<0000001<0000001<0000001<000000???<0000???<0000???<0000|}
```

- * 30H = "0"
- 31H = "1"
- 32H = "2"
- 33H = "3"
- 34H = "4"
- 35H = "5"
- 36H = "6"
- 37H = "7"
- 38H = "8"
- 39H = "9"
- 3AH = "."
- 3BH = ","
- 3CH = "<"
- 3DH = "="
- 3EH = ">"
- 3FH = "?"

6.23 GRAPHIC COMMAND

{SG

Function	Draws graphic data.																				
Format	{SG; aaaa, bbbb, cccc, dddd, e, ggg --- ggg } or {SG0; aaaa, bbbb, cccc, dddd, e, ffff, ggg --- ggg }																				
Term	<p>aaaa: Print origin of X-coordinate for drawing graphic data Fixed as 4 digits (in 0.1 mm units)</p> <p>bbbb: Print origin of Y-coordinate for drawing graphic data Fixed as 4 digits (in 0.1 mm units)</p> <p>cccc: No. of graphic width dots Fixed as 4 digits (in dots) However, when the graphic data "2: BMP file" or "6: PCX file" is selected, this designation is ignored. (The information of the graphic width is contained in the graphic data.)</p> <p>dddd: No. of graphic height dots Fixed as 4 digits (in dots) However, when the graphic data "2: BMP file" or "6: PCX file" is selected, this designation is ignored. (The information of the graphic height is contained in the graphic data.) When "3: TOPIX compression mode" is selected for the type of graphic data: Resolution of graphic data: *only two types <table border="0"> <tr> <td style="font-size: 3em; vertical-align: middle;">{</td> <td style="padding-left: 10px;">0150: 150 dpi (The data is drawn in double resolution.)</td> </tr> <tr> <td style="font-size: 3em; vertical-align: middle;">}</td> <td style="padding-left: 10px;">0300: 300 dpi (The data is drawn in single resolution.)</td> </tr> </table> </p> <p>e: Type of graphic data In the case of {SG; ~ <table border="0"> <tr> <td style="padding-right: 20px;">0: Nibble mode (4 dots/byte)</td> <td>Overwrite drawing</td> </tr> <tr> <td>1: Hex. mode (8 dots/byte)</td> <td>Overwrite drawing</td> </tr> <tr> <td>2: BMP file mode</td> <td>Overwrite drawing</td> </tr> <tr> <td>3: TOPIX compression mode</td> <td>Overwrite drawing</td> </tr> <tr> <td>4: Nibble mode (4 dots/byte)</td> <td>OR drawing</td> </tr> <tr> <td>5: Hex. mode (8 dots/byte)</td> <td>OR drawing</td> </tr> <tr> <td>6: PCX file mode</td> <td>Overwrite drawing</td> </tr> </table> In the case of {SG0; ~ <table border="0"> <tr> <td style="padding-right: 20px;">A: Compression mode for the printer driver</td> <td>Overwrite drawing</td> </tr> </table> </p> <p>ffff: Data count (Effective only for {SG0; ~) Fixed as 4 digits Represents the total byte count of the compressed graphic data by 32 bits in HEX. Range: 0 to 4,294,967,295 bytes (00H, 00H, 00H, 00H, to FFH, FFH, FFH, FFH)</p> <p>ggg --- ggg: Graphic data</p>	{	0150: 150 dpi (The data is drawn in double resolution.)	}	0300: 300 dpi (The data is drawn in single resolution.)	0: Nibble mode (4 dots/byte)	Overwrite drawing	1: Hex. mode (8 dots/byte)	Overwrite drawing	2: BMP file mode	Overwrite drawing	3: TOPIX compression mode	Overwrite drawing	4: Nibble mode (4 dots/byte)	OR drawing	5: Hex. mode (8 dots/byte)	OR drawing	6: PCX file mode	Overwrite drawing	A: Compression mode for the printer driver	Overwrite drawing
{	0150: 150 dpi (The data is drawn in double resolution.)																				
}	0300: 300 dpi (The data is drawn in single resolution.)																				
0: Nibble mode (4 dots/byte)	Overwrite drawing																				
1: Hex. mode (8 dots/byte)	Overwrite drawing																				
2: BMP file mode	Overwrite drawing																				
3: TOPIX compression mode	Overwrite drawing																				
4: Nibble mode (4 dots/byte)	OR drawing																				
5: Hex. mode (8 dots/byte)	OR drawing																				
6: PCX file mode	Overwrite drawing																				
A: Compression mode for the printer driver	Overwrite drawing																				

Explanation

- (1) When the graphic data "0" or "1" is selected, the graphic data is drawn by overwriting the image buffer.
- (2) When the graphic data "4" or "5" is selected, the graphic data is drawn by carrying out OR between the graphic data and the data in the image buffer.

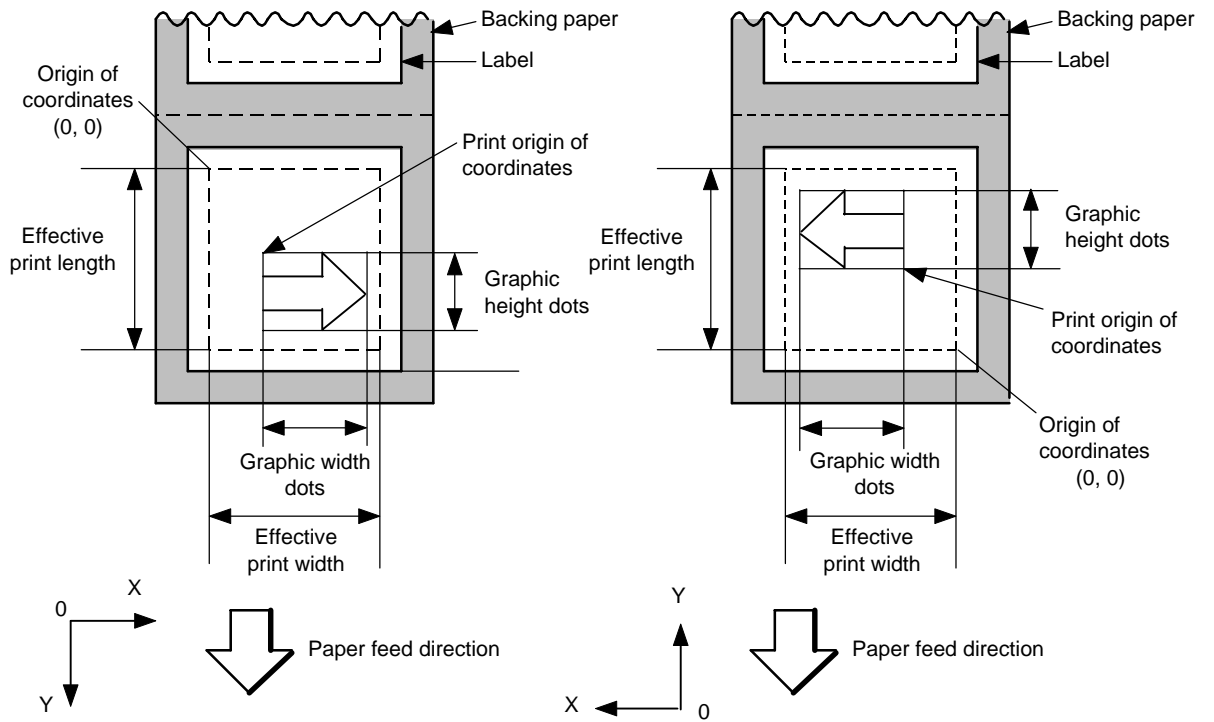

[Print direction: Printing bottom first]

[Print direction: Printing top first]

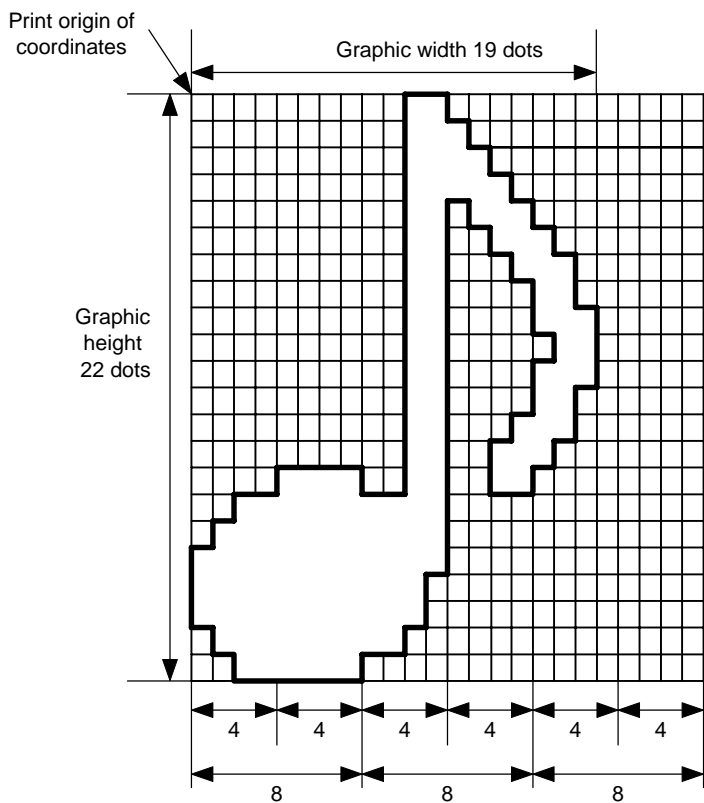

Nibble mode					
1	30H	2	30H	3	33H
4	30H	5	30H	6	30H
7	30H	8	30H	.	
				.	
				.	
				.	
				.	
				.	
				.	
				.	
				.	126 30H
127	33H	128	3FH	129	30H
130	30H	131	30H	132	30H

Hex. mode					
1	00H	2	30H	3	00H
4	00H	5	38H	.	
				.	
				.	
				.	
				.	
				.	
				.	
				.	63 00H
64	3FH	65	00H	66	00H

[Nibble mode]

- (1) The graphic data is separated into four dot units and sent in the following order (**1** → **132**). (High order digit: “3”)
- (2) The graphic data is 30H to 3FH.
- (3) The minimum unit in the X direction is 8 dots. Dots with no data are transmitted as data 0.
- (4) The graphic data count must be as follows:

$$\text{Graphic data count} = \{(\text{No. of graphic width dots} + 7) / 8\} \times \text{No. of graphic height dots} \times 2$$

* The value in the brackets is rounded down to the nearest whole number.

[Hex. mode]

- (1) The graphic data is separated into eight dot units and sent in the following order (**1** → **66**).
- (2) The data of graphic data is 00H to FFH.
- (3) The minimum unit in the X direction is 8 dots. Dots with no data are transmitted as data 0.
- (4) The graphic data count must be as follows:

$$\text{Graphic data count} = \{(\text{No. of graphic width dots} + 7) / 8\} \times \text{No. of graphic height dots}$$

* The value in the brackets is rounded down to the nearest whole number.

[When TOPIX compression mode is selected:]

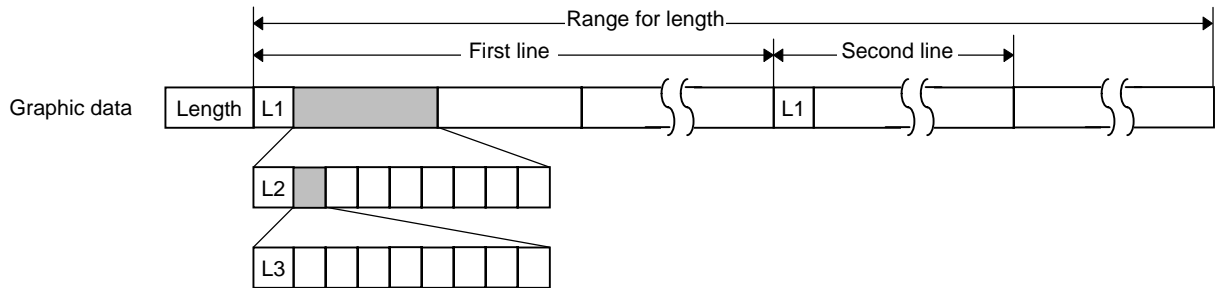

(1) Length: Total number of bytes of the graphic data (0001H ~)

Ex. Length = 20 bytes:

00	14
----	----

(2) L1 parameter: Shows in which large block (512 dots/block) the changed data is contained.

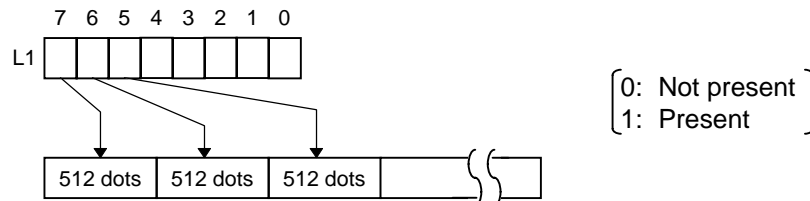

(3) L2 parameter: Shows in which medium block (64 dots/block) the changed data is contained (of the L1 large block).

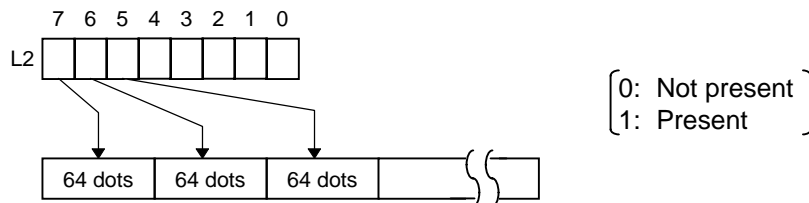

(4) L3 parameter: Shows in which small block (8 dots/block) the changed data is contained (of the L2 medium block).

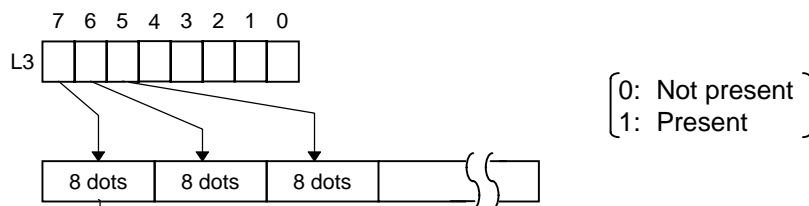

Exclusive-OR is carried out between the current image data and the image data one line previous. Only the changed bit is set to ON (1). The alignment of dots is MSD (left dots) and LSB (right dots).

* The graphic width for only the smaller value of either the designated value or the max. buffer size (512 KB) is drawn. The minimum unit of the data drawing is 8 dots (1 byte). If the graphic width is set to 3 dots, it will be reset to 8 dots (1 byte).

[When the compression mode for the printer driver is selected:]

- (1) For the {SG0; ~ command, only "A: Compression mode for the printer driver" can be selected for the type of graphic data. The parameter for the data count is attached after the parameter for the type of graphic data. When the total of data count cannot be provided by the printer driver, "00H, 00H, 00H, 00H" should be specified for the graphic data count. However, in this case, the printer driver cannot support printing through a serial interface (RS-232C).

- (2) How to compress data

Compression is performed for every data of one line specified for the number of graphic width dots.

The data is made up in units of 8 dots. A repeated value is encoded in 2 bytes. The first byte is a numeric value n indicating that a value is repeated (-n + 1) times.

The range is between -127 and -1. The second byte is the repeated value.

If a value is not repeated, the first byte is the numeric value m. The length of the values is indicated in (m+1). The range of "m" is between 0 and 126. The length of the repetition of the value "n" and "m" should not exceed 127 and 126, respectively.

If it exceeds the range, it should be divided into blocks of repetition.

When the same contents as the data for 1 line appear repeatedly in the next line and after, the number of lines in which the same contents appear is encoded in 2 bytes. The first byte is fixed as 127. The second byte indicates "N" times that the same contents are repeated. Its range is between 1 and 255. "N" should not exceed 255. If it exceeds the range, the data of 1 line should be compressed again, and the remaining number of repetitions should be encoded.

[Example]

Data before being compressed (Width: 120 dots, Height: 300 lines)

Line No.	Graphic data
1	AAh AAh AAh AAh AAh AAh AAh BBh CCh DDh EEh FFh FFh FFh FFh
2	AAh AAh AAh AAh AAh AAh AAh BBh CCh DDh EEh FFh FFh FFh FFh
	⋮
299	AAh AAh AAh AAh AAh AAh AAh BBh CCh DDh EEh FFh FFh FFh FFh
300	AAh AAh AAh AAh AAh AAh AAh BBh CCh DDh EEh FFh FFh FFh FFh

Data after being compressed

Line No.	Graphic data
1	<u>FAh AAh 03h BBh CCh DDh EEh FDh FFh</u>
2 to 256	7FH FFH
257	<u>FAh AAh 03h BBh CCh DDh EEh FDh FFh</u>
258 to 300	7FH 2BH

FAh = -6
 $-(-6) + 1 = 7$
 AAh is repeated 7 times.

03h = 3
 $3 + 1 = 4$
 4-byte data (BBh CCh DDh EEh) without repetition

FDh = -3
 $-(-3) + 1 = 4$
 FFh is repeated 4 times.

Note

- (1) The print origin of coordinates must be set so that result of drawing the graphic data will be within the effective print area set by the Label Size Set Command ({D}).
- (2) The number of graphic width dots and number of graphic height dots must also be set so that the result of drawing the graphic data will be within the effective print area set by the Label Size Set Command ({D}) in the same manner as above.
- (3) Both width and height are 11.8 dots/mm.
- (4) The actual result of drawing may deviate within ± 0.34 mm in the X direction with respect to the designated print origin of X-coordinate.

To draw the received graphic data at high speed, the data is directly developed into the image buffer without applying correction to each bit with respect to the designated X-coordinate. Consequently, an error of up to 4 bits occurs.

- (5) The graphic data overwrites the image buffer.

[Effective print area]		[mm]			
Item	Model		B-452		
	Method	Batch	Strip	Cut	
Effective print width		Min.	10.0		
		Max.	105.7		
Effective print length	Label	Min.	11.0	21.4	29.0
		Max.	500.0		
	Tag	Min.	13.0	23.4	
		Max.	500.0		

Examples

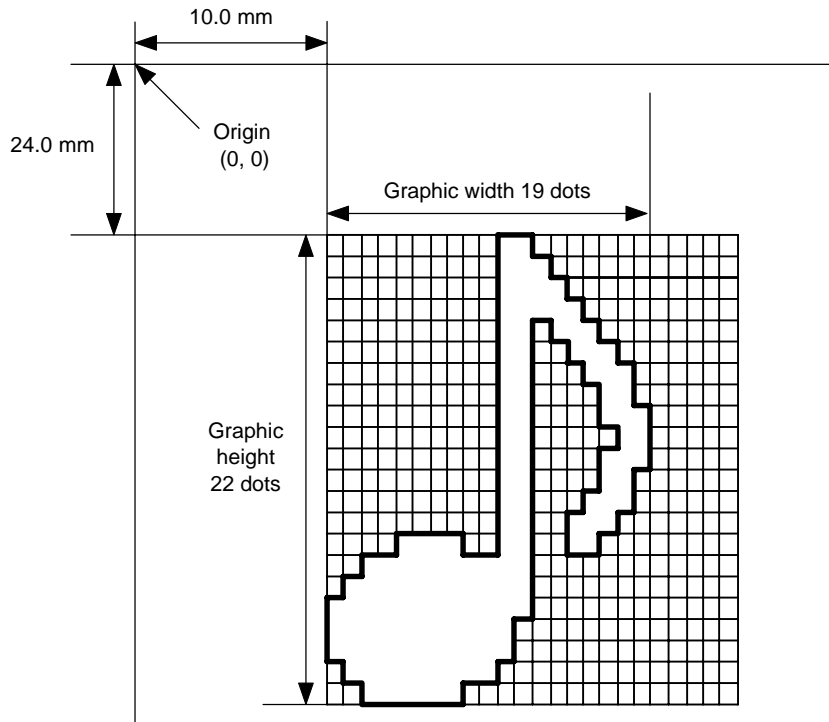

```
{C}
{SG; 0100, 0240, 0019, 0022, 0, 003000003800003<00003>000037000033800031<
00030<00030>00030600030>00030<00031<00033800?33003??0007??000??000??>
000??>0007?<0003?0000}}
{XS; I, 0001, 0002C2000}
```

- * 30H = "0"
- 31H = "1"
- 32H = "2"
- 33H = "3"
- 34H = "4"
- 35H = "5"
- 36H = "6"
- 37H = "7"
- 38H = "8"
- 39H = "9"
- 3AH = "."
- 3BH = ","
- 3CH = "<"
- 3DH = "="
- 3EH = ">"
- 3FH = "?"

[TOPIX compression mode]

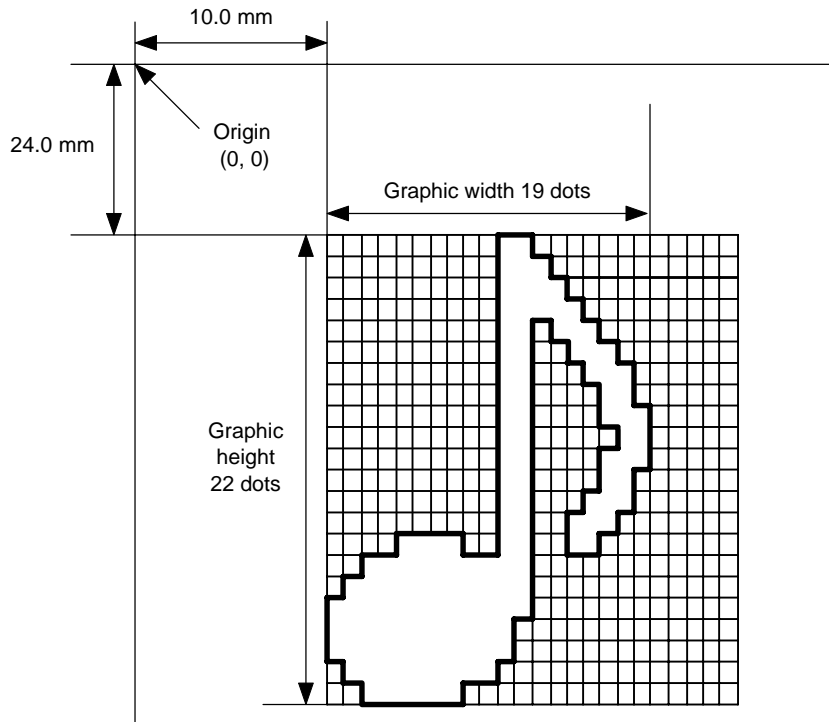

```
{SG; 0100, 0240, 0019, 0300, 3, 00 5C 80 80 40 30
                                     Length L1 L2 L3 Data (1st line)

80 80 40 08 80 80 40 04 80 80 40 02 80 80 40 09
  (2nd line)   (3rd line)   (4th line)   (5th line)

80 80 60 04 80 80 80 60 02 40 80 80 40 01 80 80 20 20
  (6th line)     (7th line)     (8th line)   (9th line)

80 80 20 80 80 80 20 80 80 80 20 20 80 80 40 01
  (10th line)  (11th line)  (12th line) (13th line)

80 80 60 02 40 80 80 A0 0F 80 80 80 C0 30 C3 80 80 80 40
  (14th line)    (15th line)  (16th line) (17th line)

80 80 80 80 80 80 40 10 00 80 80 C0 80 20 80 80 C0 40 C0}
  (18th line)  (19th line) (20th line) (21st line) (22nd line)
```

6.24 SAVE START COMMAND

{XO}

Function	Declares the start of saving PC interface commands. (Places the printer in the mode where PC interface commands are written in the flash memory.)
Format	{XO; aa, b}
Term	aa: Identification number (save No.) used for saving or calling 01 to 40 b: Status response at save time 0: No status response made 1: Status response made
Notes	(1) Up to 40 kinds of PC interface commands can be stored. The maximum number of PC interface commands varies according to the PC interface command capacity to be stored because of the limited memory capacity. The storable command capacity per saving operation is as follows: PC save area is 7 KB: 7166 bytes PC save area is 64 KB or more: 65533 bytes (2) The remaining memory after formatting depends on the specified capacity of the PC save area. (3) The already stored save number can be stored again when the Save Start Command ({XO}) is sent after declaring the termination of saving. However, the memory is consumed every storing again. The memory can be used efficiently by sending the Format Command ({J1}) before storing. (4) After sending the Save Start Command ({XO}), any command other than the following will be saved into the flash memory without being analyzed. <ul style="list-style-type: none">• Save Start Command ({XO})• Save Terminate Command ({XP})• Saved Data Call Command ({XQ})• Bit Map Writable Character Store Command ({XD})• Reset Command ({WR})• Status Request Command ({WS})• Format Command ({J1}) (5) No error check is made for the commands at save time.
Refer to	<ul style="list-style-type: none">• Save Terminate Command ({XP})• Format Command ({J1})
Examples	{J1; B} {XO; 01, 0} {D0508, 0760, 0468} {T20C20} {C} {PC001; 0200, 0125, 1, 1, A, 00, B} {PC002; 0650, 0550, 2, 2, G, 33, B, +0000000001} {XP}

6.25 SAVE TERMINATE COMMAND

{XP}

Function	Declares the termination of saving PC interface commands.
Format	{XP}
Note	If the storing operation is not continued after storing the PC interface command, the printer enters the online mode (label issue operation) after about 10 seconds. In this case, the image buffer will be cleared automatically.
Refer to	Save Start Command ({XO})

6.26 SAVED DATA CALL COMMAND

{XQ}

Function	Calls saved PC interface commands.
Format	{XQ; aa, b, c}
Term	aa: Save number of the file to be called 01 to 40 b: Status response when calling the data 0: No status response made 1: Status response made c: Auto call at power on time L: Auto call M: No auto call
Notes	(1) If the relevant save number is not found, an error will result. (2) However, if no save number subject to auto call is found with the option for auto call at power on time selected, the option for no auto call will be selected causing no error. (3) If a command error is found in the PC interface command in auto call at power on time by the Saved Data Call Command, a command error will result. After an error has occurred, the power must be turned off. The option for no auto call is selected when the power is turned on again. Also when the printer is reset by using the key on the printer, the option for no auto call is selected. (For resetting with the key on the printer, refer to chapter 10.) (4) The printer enters the online mode (label issue operation) when the Saved Data Call Command is sent after the Save Terminate Command.
Refer to	<ul style="list-style-type: none">• Save Start Command ({XO})• Save Terminate Command ({XP})
Examples	{XQ; 01, 0, L} {RC001; Sample} {RC002; 100} {XS; I, 0002, 0002C2000}

6.27 RESET COMMAND

{WR

Function	Returns the printer to its initial state.
Format	{WR}
Explanation	Returns the printer to the same state as when the power was turned on. When the printer receives this command during printing, it returns to its initial state after issuing the label being printed. The next data must not be sent for a minimum of 3 seconds after this command is transmitted.
Notes	<ol style="list-style-type: none">(1) The Reset Command is effective in serial interface (RS-232C) only. In parallel interface (Centronics), the reset request signal (INPUT • PRIME) should be used.(2) When the printer receives a command in the self-test mode or the maintenance mode, only the Reset Command can be used and any other command cannot be used.(3) After the code of the Writable Character Command ({XD) or Graphic Command ({SG) is received, the Reset Command is not processed until the printer receives the type of data.
Example	{WR}

6.28 STATUS REQUEST COMMAND

{WS

Function	Sends the printer status to the host computer.
Format	{WS}
Explanation	This command makes the printer send its status regardless of the setting of “status response/no status response”. The status to be transmitted is the current printer status, and indicates the latest status only. The remaining count indicates the remaining count of the batch currently being printed. No remaining count of the batch waiting to be printed is transmitted.
Notes	<ol style="list-style-type: none">(1) The Status Request Command is effective in serial interface (RS-232C) only. Since the status cannot be sent in parallel interface (Centronics), this command is not supported.(2) After the code of the Writable Character Command ({XD) or Graphic Command ({SG) is received, the Status Request Command is not processed until the printer receives the type of data.
Example	{WS}

6.29 PARAMETER SET COMMAND

{ZZ

Function	Sets each parameter.
----------	----------------------

Format	{ZZ; a, b, c, d, e, f, g, hh, i, jjj, kk, ll}
--------	---

The parameters should be separated with a comma “,”. If a parameter is omitted, it means that it is not changed. When parameters are omitted at the end of command, the commas can also be omitted.

Ex.) {ZZ; , , c, d, , , , , , , }

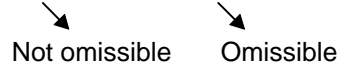

Term	<p>aa: Transmission control</p> <ul style="list-style-type: none"> 0: XON/XOFF protocol (No XON/XOFF output when the power is turned on/off) 1: READY/BUSY (DTR) protocol (No XON/XOFF output when the power is turned on/off) 2: XON/XOFF + READY/BUSY (DTR) protocol (XON/XOFF output when the power is turned on/off) 3: XON/XOFF protocol (XON/XOFF output when the power is turned on/off) 4: READY/BUSY (RTS) protocol (No XON/XOFF output when the power is turned on/off)
------	--

b: Character code 5CH “𐤀” or “\” selection

- 0: “𐤀”
- 1: “\”

The initial value when the parameter clear is performed depends on whether the Kanji ROM is installed or not.

Kanji ROM installed: “𐤀”

Kanji ROM not installed: “\”

c: Character code selection

- 0: PC-850 (MS-DOS/Latin1)
- 1: PC-8
- 2: PC-852 (MS-DOS/Latin2)
- 3: PC-857 (MS-DOS/Turkish)
- 4: PC-851 (MS-DOS/Greek1)
- 5: PC-855 (MS-DOS/Cyrillic)
- 6: PC-1250 (Windows/Latin2)
- 7: PC-1251 (Windows/Cyrillic)
- 8: PC-1252 (Windows/Latin1)
- 9: PC-1253 (Windows/Greek)
- A: PC-1254 (Windows/Turkish)
- B: PC-1257 (Windows/Baltic Rim)
- C: LATIN9
- D: Arabic

- d: Font "0" selection
 0: 0 (without slash)
 1: Ø (with slash)
- e: Kanji code selection
 0: Type 1
 1: Type 2
- f: Control code selection
 0: Automatic selection
 1: Manual selection (ESC, LF, NUL mode)
 2: Manual selection ({, |, } mode)
- g: Strip status
 0: Without
 1: With
 When the strip status for the last label in the strip mode is "0: Without" or "1: With", it indicates "Normal end" or "Strip waiting", respectively.
- hh: Euro code
 20 to FF (in Hex.)
 * Euro code can be assigned to between 20H and FFH.
 If any font has been assigned to the specified code, the Euro code must be assigned. After the parameter clear is performed, the initial value is B0H.
- i: Indicates the direction in which the X-coordinate is to be adjusted
 +: Right direction
 -: Left direction
- lll: X-coordinate fine adjustment value
 000 to 995 (in units of 0.5 mm)
 * All X-coordinates in the print format are adjusted. However, any X-coordinates should not be adjusted in the negative direction such that they become 0 or less.
- kk: Manual threshold fine adjustment value (Reflective)
 00 to 40 (in units of 0.1 V)
- ll: Manual threshold fine adjustment value (Transmissive)
 00 to 40 (in units of 0.1 V)

Notes

- (1) The parameters set by this command become effective when the power is turned off/on, or the Reset Command is sent. However, the next command should not be sent within 3 seconds after the Reset Command is sent.

6.30 TRANSFER COMMAND (LAN → KB-80)

{MA

Function	Transfers the data to the KB-80, which is sent from the LAN to the KB-80.
----------	---

Format	{MAaaaaa....aaaaa}
--------	--------------------

Term	aa...aa: Data to be sent from the LAN to the KB-80. The application prescribes the transmission data specifications.
------	---

Ex.) {MAFormat Not Found}
The KB-80 displays "Format Not Found" as a message from the LAN host.

6.31 TRANSFER COMMAND (KB-80 → LAN)

{NA

Function	Transfers the data to the LAN, which is sent from the KB-80 to the LAN.
Format	{NAaaaa...aaaa}
Term	aa...aa: Data to be sent from the KB-80 to the LAN. The application prescribes the transmission data specifications.

Ex.) {NALABEL0101}
The LAN host receives a request for issuing a label of Format No. 01 and Data No. 01.

Notes

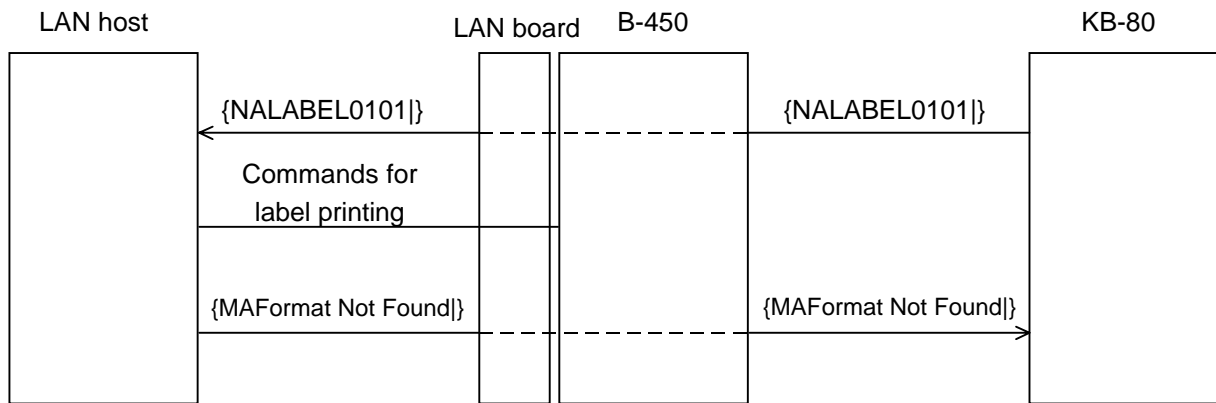

6.32 STORAGE AREA ALLOCATE COMMAND

{XF

Function	Allocates the storage area in flash ROM on the CPU board.
Format	{XF; aa (, bb)}
Term	aa: Size of the TrueType font storage area 00 to 15 (0 KB to 960 KB)(in units of 64 KB) bb: Size for bit map writable character storage area (omissible) 00 to 15 (0 KB to 960 KB)(in units of 64 KB)
Explanation	<ol style="list-style-type: none">(1) The storage area in expanded flash ROM has a total capacity of 960 KB.(2) If the above command is received, the complete area in expanded flash ROM is cleared.(3) If the above command is not sent, all storage area in expanded flash ROM is used for the bit map writable character storage area. Another 7 KB of the PC save area are allocated.(4) The area specified by the above command is allocated in order from the TrueType font storage area to the bit map writable character storage area. The remaining area is used for the PC save storage area.(5) If the sum of TrueType font storage area and bit map writable character storage area specified by the above command is 960 KB, each specified capacity of the TrueType font storage area and bit map writable character storage area is allocated. Another 7 KB of the PC save storage area are allocated.(6) If the sum of the TrueType font storage area and bit map writable character storage area specified by the above command exceeds 960 KB, the TrueType font storage area is allocated as specified, and the remaining area is used for the bit map writable character storage area. Another 7 KB of the PC save storage area are allocated.(7) When "00" (0 KB) is specified for the bit map writable character storage area, the TrueType font storage area is allocated as specified, and the remaining area is used for the PC save storage area. Therefore, the bit map font storage area is not allocated.(8) When "00" (0 KB) is specified for the TrueType font storage area, the bit map writable character storage area is allocated as specified, and the remaining area is used for the PC save storage area. Therefore, the TrueType font storage area is not allocated.(9) When "15" (960 KB) is specified for the TrueType font storage area, all area is used for the TrueType font storage area. Therefore, the writable character storage area is not allocated. However, another 7 KB of the PC save area are allocated.(10) When "00" (0 KB) and "15" (960 KB) are specified for the TrueType font storage area and the bit map writable character font storage area, respectively, all area is used for the bit map writable character storage area. Therefore, the TrueType font storage area is not allocated. However, another 7 KB of the PC save area are allocated.

- (11) When "00" (0 KB) is specified for both the TrueType font storage area and the bit map writable character font storage area, all area is used for the PC save storage area. Therefore, neither the TrueType font storage area nor bit map writable character storage area is allocated.
- (12) If the size of the bit map writable character storage area is not specified, the TrueType font storage area is allocated as specified, and the remaining area is used for the bit map writable character storage area. Another 7 KB of the PC save area are allocated.

Refer to

- Bit Map Writable Character Command ({XD})
- Save Start Command ({XO})
- Memory Card Format Command ({J1})
- 2-byte Writable Character Code Range Command ({XE})

Example

The TrueType font storage area and bit map writable characters storage area are set to 640 KB and 192 KB, respectively.

(PC save storage area: $960 \text{ KB} - 640 \text{ KB} - 192 \text{ KB} = 128 \text{ KB}$)

{XF; 10, 03}

7. CONTROL CODE SELECTION

(1) Automatic Selection

This machine automatically selects [ESC] (1BH). [LF] (0AH). [NUL] (00H) or {(7BH). | (7CH).} (7DH) as an interface command control code. After the power is turned on, the program checks the data from the host for [ESC] and { and assumes the data whichever has been sent first to be a control code.

For example, if [ESC] is sent first after the power is turned on, [ESC]. [LF]. [NUL] becomes a control code, and if { is sent first, { . | . } becomes a control code. Control code selection is made for every command. If the first command is [ESC] ~ [LF] [NUL], followed by [ESC], the control code becomes [ESC]. [LF]. [NUL], and if it is followed by { , the control code for the next command becomes { . | . }. When { . | . } is a control code, the data of 00H to 1FH in { ~ | } is ignored. However, the data of 00H to 1FH becomes valid while processing the Graphic Command or Writable Character Command in hexadecimal mode. When { . | . } is a control code, { . | . } cannot be used in the data of the Data Command.

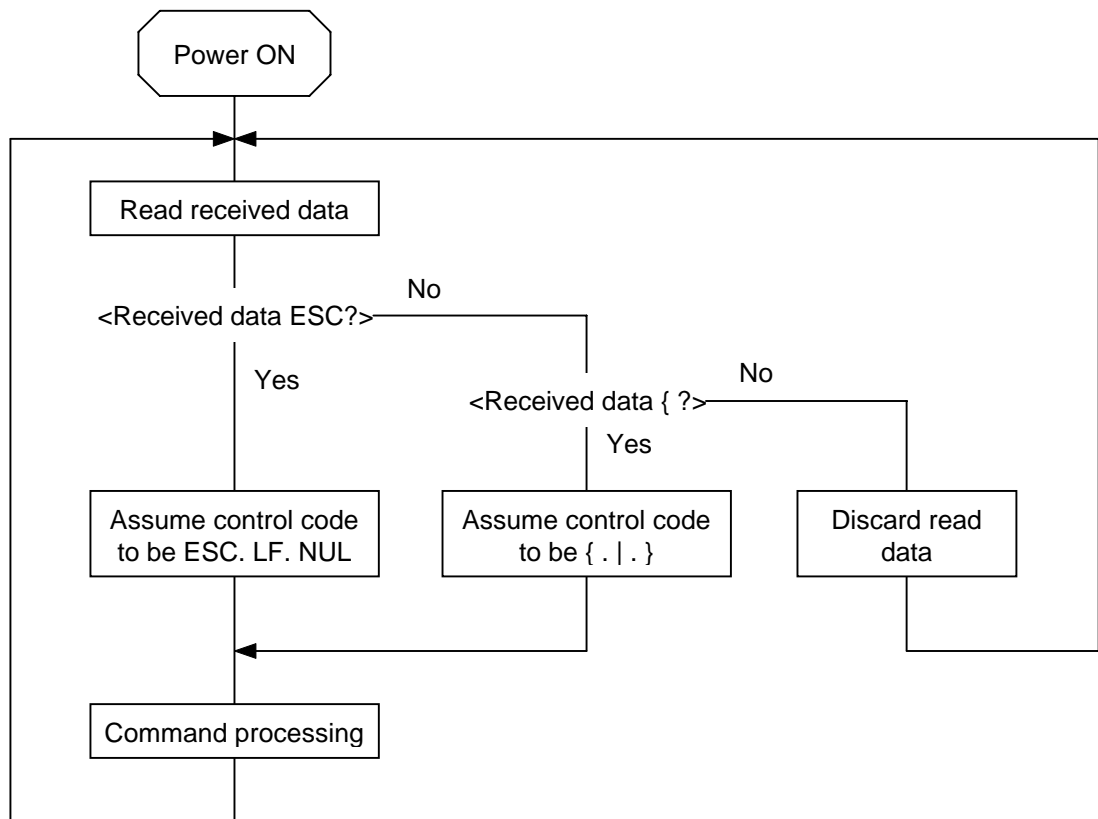

(2) Manual Selection (ESC. LF. NUL)

The control code of the command is [ESC] (1BH). [LF] (0AH). [NUL] (00H), and the control code selection is not performed.

(3) Manual Selection ({ . | . })

The control code of the command is {(7BH). | (7CH).} (7DH), and the control code selection is not performed. Data of 00H to 1FH is ignored and discarded in this mode. However, data of 00H to 1FH becomes valid while processing the Graphic Command or Writable Character Command in hexadecimal mode. { . | . } cannot be used in the data of the Data Command.

8. ERROR PROCESSING

If the printer detects any of the following errors, it indicates an error state (LED), makes a status response (serial interface, parallel interface), and stops operating.

8.1 COMMUNICATION ERRORS

(1) Command Errors

An error results if a command length error, command transmission sequence error, command format error or parameter designation error is found in analyzing the command. An error results if the Format Command of a field is not transmitted and its Data Command is transmitted. When calling the PC Save Command of the field which is not saved is attempted, an error results. An undefined command is not detected as an error, and data is discarded until [NUL] or [] is received.

(2) Hardware Errors

An error results if a framing error, overrun error or parity error is found during data reception when using the serial interface (RS-232C).

* At the moment a command error or hardware error occurs, the printer lights the LED to indicate an error state and makes a status response before stopping. The Status Request Command and Reset Command only can be processed and other commands are not processed. When the printer is restored by the [PAUSE] key, the printer enters the initial state which is obtained after the power is turned on.

8.2 ERRORS IN ISSUING OR FEEDING

(1) Feed Jam

① When the relation between the programmed label (or tag) pitch (A) and the label (or tag) pitch detected by the sensor (B) is not indicated by the following formula, an error will result: $(A) \times 50\% \leq (B) \leq (A) \times 150\%$

- A paper jam has occurred during paper feed.
- The paper is not placed properly.
- The actual label does not match the type of the sensor.
- The sensor position is not aligned with the black mark.
- The actual label size does not meet the designated label length.
- No label-to-label gap is detected due to preprint.
- The sensor is not thoroughly adjusted.

(The sensor is not adjusted for the label to be used.)

② If the stripped label does not cover the strip sensor when printing or feeding is completed in the strip mode, an error will result.

(2) Cutter Error

The cutter home position sensor does not operate 1.5 seconds or more after the cutter motor is driven, an error will result.

- A paper jam has occurred at the cutter. (The cutter does not return to the home position.)
- The cutter does not move from the home position.

(3) Label End

① When the transmissive sensor and reflective sensor detect the label end state for 3 mm continuously, an error will result.

② If the transmissive sensor and reflective sensor detect the label end state when an issue, feed and ejection is attempted when the printer stops, an error will result.

(4) Head Open Error

- ① If the head open sensor detects the open state for 5 mm continuously, an error will result.
- ② If the head open sensor detects the open state when an issue, feed and ejection is attempted in the printer stop state, an error will result.
However, this does not include feeding by the [FEED] key on the printer.

(5) Thermal Head Temperature Abnormal

- ① When the open-air temperature detection thermistor detects a high temperature, an error will result.
- ② When the thermal head temperature detection thermistor detects a high temperature, an error will result.
- ③ When the heat sink sensor detects a high temperature, an error will result.

(6) Ribbon Error

- ① If the motor speed calculated from the ribbon rewind motor sensor and ribbon back tension motor sensor is not in the acceptable range, an error will result.
 - The ribbon has been used up.
 - The ribbon is not installed.
 - A ribbon jam has occurred.
 - The ribbon has been torn.
 - An abnormal condition has occurred in the ribbon motor sensor.

(7) Connection of the open-air temperature detection thermistor connector

If the open-air temperature detection thermistor connector is not connected properly, an error occurs.

8.3 ERRORS IN WRITABLE CHARACTER AND PC COMMAND ENTRY MODES

(1) Write Error

- An error has occurred in writing in the flash memory.

(2) Format Error

- An erase error has occurred in formatting the flash memory.

(3) Memory Full

- Storing is impossible because of the insufficient flash memory capacity.

* At the moment an error occurs, the printer lights the LED to indicate an error state and makes a status response before stopping. The Status Request Command and Reset Command only can be processed and other commands are not processed. Restoration using the [PAUSE] key is impossible.

8.4 SYSTEM ERRORS

(1) Zero Dividing Error

- The CPU has detected a zero dividing error. (The program is not running normally.)

(2) Momentary Power Interruption Error

- A momentary power interruption has occurred.

* At the moment an error occurs, the printer lights the LED to indicate an error state and makes a status response before stopping. (None of the commands and key operations will be processed.)

(3) EEPROM Error

- The EEPROM for back-up cannot be read/written properly.

8.5 RESET PROCESSING

When the [PAUSE] key is pressed for more than 3 seconds during the error which can be cleared by the [PAUSE] key and during a pause, the printer returns to the initial status which is obtained after the power is turned on.

9. STATUS RESPONSE

9.1 SERIAL INTERFACE

9.1.1 Functions

There are the following two kinds of status response functions.

- (1) Status transmission function at the end of normal transmission and occurrence of an error (auto status transmission)

If the option for “status response” has been selected, the printer sends the status to the host computer at the feeding and at the issuing normally (batch/cut mode: after the designated number of labels are printed, strip mode: after printing one label). In the online mode, the head up/down status is sent to the host computer.

When each error occurs, the status is sent to the host computer.

The remaining count of the status response indicates the remaining count of the batch currently being printed. No remaining count of the batch waiting to be printed is transmitted.

- (2) Status transmission function by status request (Status Request Command)

Upon request to send status by the Status Request Command, the printer sends the latest status indicating its current status to the host computer, regardless of the option for “status response/no status response.” The remaining count indicates the remaining count of the batch currently being printed. No remaining count of the batch waiting to be printed is transmitted. This command is not stored in the receive buffer and executed immediately after reception.

- Strip status

How the strip status (05H) is returned by the Status Request Command varies depending on the setting.

When the setting is “without strip status”:

If the Status Request Command is sent when a label is on the strip shaft (for example, while idling, after feeding a label, after printing all labels), the printer returns (00H).

When the setting is “with strip status”:

If the Status Request Command is sent when a label is on the strip shaft (for example, while idling, after feeding a label, after printing all labels), the printer returns (05H).

If the Status Request Command is sent while a label is being printed or issued, the strip status (05H) is returned for both settings.

9.1.2 Status Format

SOH	STX	Status			Remaining count				ETX	EOT	CR	LF
01H	02H	3XH	3XH	3XH	3XH	3XH	3XH	3XH	03H	04H	0DH	0AH

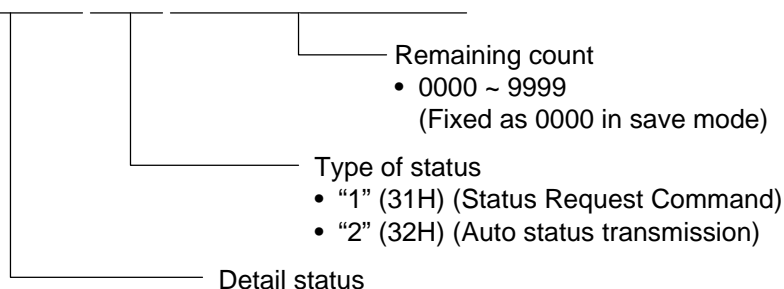

9.1.3 Detail Status

Printer Status	Detail Status	
	Auto Status Transmission	Status Request Command
Idling state	–	00
The head was closed with the head open.	00	–
The head was opened in the online mode.	01	01
In operation (Analyzing command, drawing, printing, feeding)	–	02
In a pause state	–	04
Strip waiting state	–	05
A command error was found in analyzing the command.	06	06
A parity error, overrun error or framing error occurred during communication by RS-232C	07	07
A paper jam occurred during paper feed.	11	11
An abnormal condition occurred at the cutter.	12	12
The label has run out.	13	13
An attempt was made to feed or issue with the head open (except the [FEED] key).	15	15
The thermal head temperature has become excessively high.	18	18
Ribbon error (The ribbon has been used up, or been torn.)	21	21
Disconnection of the open-air temperature detection thermistor connector	22	22
The label issue has been completed normally.	40	–
The feed has been completed normally.	41	–
In writable character or PC command save mode	–	55
An error has occurred in writing the flash memory.	Writable character, PC command, save mode	50
An erase error has occurred in formatting the flash memory.		51
Saving failed because of the insufficient capacity of the flash memory.		54
A zero dividing error has occurred.	–	–
A momentary power interruption has occurred.	–	–
An EEPROM for back up cannot be read/written properly.	–	–

9.2 PARALLEL INTERFACE

Printer Status	Output Signal			
	BUSY	PAUSE	FAULT	PE
In the online mode	L	H	H	L
In the online mode (communicating)	L, H	H	H	L
The head was opened in the online mode.	H	L	L	L
In a pause state	H	L	L	L
Data was sent from the host with the receive buffer full.	H	H	H	L
After data was sent from the host with the receive buffer full, some data is processed and room becomes available.	L	H	H	L
Initialization process is being executed (after the power is turned on or INPUT • PRIME is received)	H	L	L	L
A command error has occurred in analyzing the command.	H	L	L	L
A paper jam occurred during paper feed.	H	L	L	L
An abnormal condition occurred at the cutter.	H	L	L	L
The label has run out.	H	L	L	H
An attempt was made to feed or issue with the head open (except the [FEED] key).	H	L	L	L
The thermal head temperature has become excessively high.	H	L	L	L
Ribbon error (The ribbon has been used up, or been torn.)	H	L	L	L
Disconnection of the open-air temperature detection thermistor connector	H	L	L	L
In writable character or PC command save mode	L	H	H	L
An error has occurred in writing in the flash memory.	H	L	L	L
An erase error has occurred in formatting the flash memory.	H	L	L	L
Saving failed because of the insufficient capacity of the flash memory.	H	L	L	L
A zero dividing error has occurred.	H	L	L	L
A momentary power interruption has occurred.	H	L	L	L
An EEPROM for back-up cannot be read/written properly.	H	L	L	L

10. KEY OPERATION

Key operation by the printer will be impossible when the power is turned on with the external keyboard, KB-80, attached. In this case, refer to TAA-1091 for key operation specification of the KB-80. (In V1.2A or later, if the KB-80 is connected to the printer, the key operation by the printer is possible.)

10.1 OPERATION PANEL

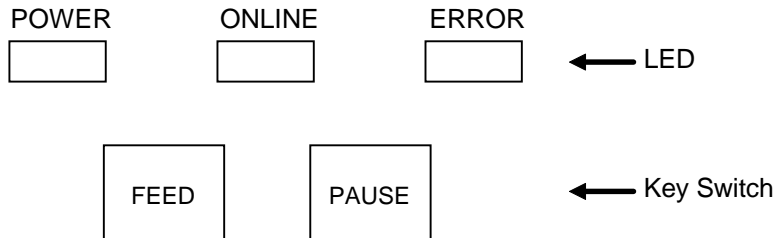

10.2 ONLINE MODE

10.2.1 Key Function

[FEED] key: Feeds one sheet of paper.

- This key is used to eject one sheet of paper.

This key is also used to adjust the paper to the proper position when the paper is not properly positioned. If printing is attempted when the paper is not properly positioned, printing will not be performed at the proper position. One or two sheets of paper should be fed to adjust the paper position before printing.

[PAUSE] key: Stops label printing temporarily and resumes printing after a temporary stop in label printing or after an error.

10.2.2 LED Function

[POWER] LED: Indicates that the printer power is ON.

[ONLINE] LED: Indicates that the printer is ready for communication.

[ERROR] LED: Indicates that the printer is in an error state.

10.2.3 Online Mode Operation Example

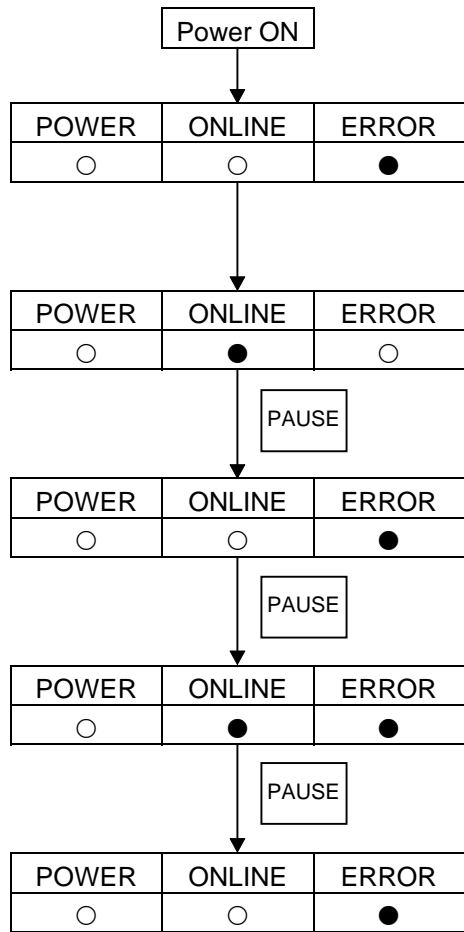

* During idling or a normal issue.

An error occurs.

* If an error occurs during an issue, the printer indicates it with LEDs like this, and stops printing.

Load labels and then press the [PAUSE] key.

* The printer resumes printing.

Press the [PAUSE] key.

* If the [PAUSE] key is pressed during an issue, the printer indicates LEDs like this, and stops printing. (Enters a pause state)

Press the [PAUSE] key.

* The printer resumes printing.

- : ON
- ⊙: Blinks
- : OFF

10.2.4 Reset

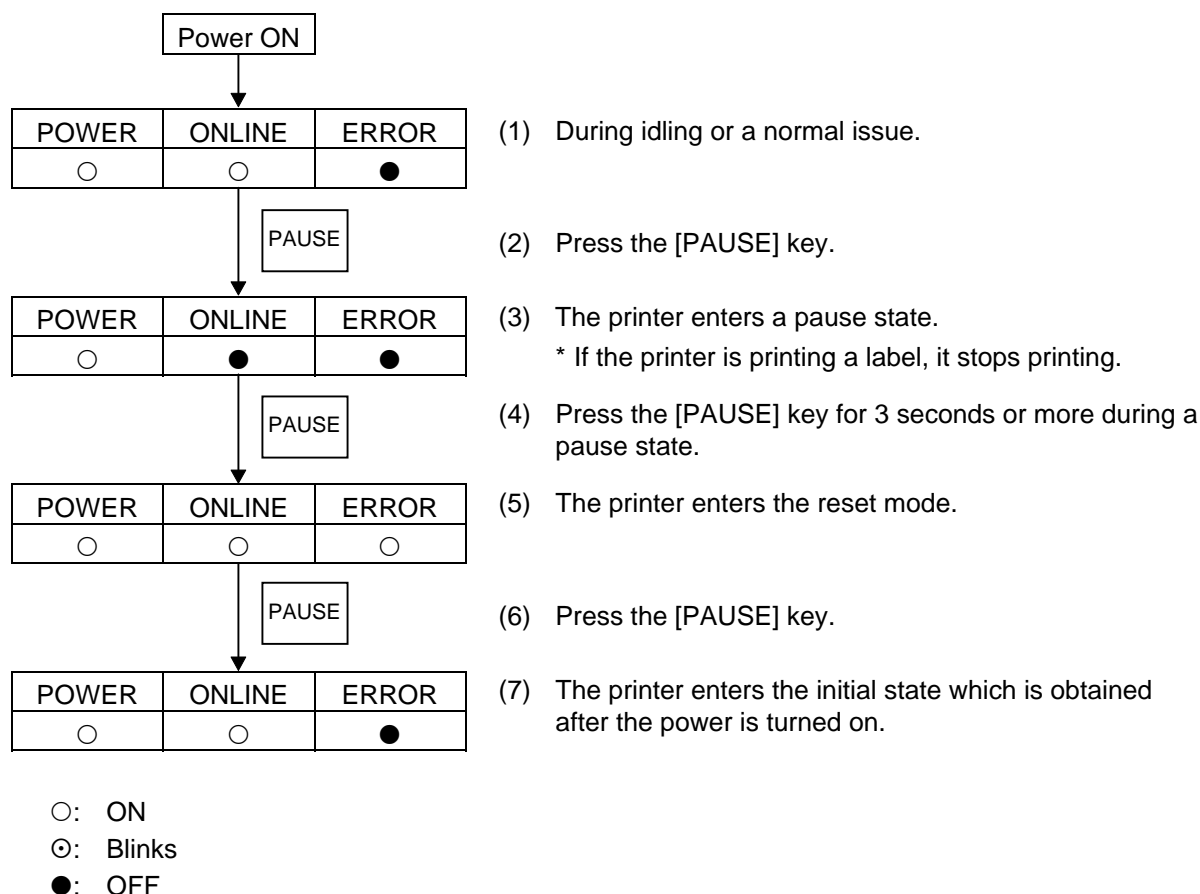

<Supplementary Explanation>

- (1) If the [PAUSE] key is pressed for 3 seconds or more when the printer can resume printing (the state of "Restoration by [PAUSE] key"), the printer enters the reset mode.
- (2) When the [PAUSE] key is released within 3 seconds after being pressed during an error or pause state, the printer resumes printing the label. (The printer does not enter the reset mode.) When a communication error or command error has occurred, however, the printer enters the usual initial state which is obtained after the power is turned on when the [PAUSE] key is pressed.
- (3) If the printer is reset by using the key on the printer, the data stored by the PC save command is not called automatically.

10.3 LED INDICATIONS

No.	Printer Status	LED Indication			Restoration by [PAUSE] key Yes/No	Acceptance of Status Request Reset Command Yes/No
		POWER	ONLINE	ERROR		
1	In the online mode	○	○	●	-	Yes
	In the online mode (Communicating)	○	⊙	●	-	Yes
2	The head was opened in the online mode.	○	●	●	-	Yes
3	In a pause state	○	●	●	Yes	Yes
4	A parity error, overrun error or framing error has occurred during communication by RS-232C.	○	●	○	Yes	Yes
5	A paper jam occurred during paper feed.	○	●	○	Yes	Yes
6	An abnormal condition occurred at the cutter.	○	●	○	Yes	Yes
7	The label has run out.	○	●	○	Yes	Yes
8	An attempt was made to feed or issue with the head open (except the [FEED] key).	○	●	○	Yes	Yes
9	The thermal head temperature has become excessively high.	○	●	○	If the head temperature is 60°C or less and the ambient temperature is 50°C or less, the printer restarts automatically.	Yes
10	Ribbon error (The ribbon has been used up or been torn.)	○	●	○	Yes	Yes
11	In writable character or PC command save mode	○	○	●	-	Yes
12	An error has occurred in writing in the flash memory.	○	●	○	No	Yes
13	An erase error has occurred in formatting the flash memory.	○	●	○	No	Yes
14	Saving failed because of the insufficient capacity of the flash memory.	○	●	○	No	Yes
15	A command error has occurred in analyzing the command.	○	●	○	Yes	Yes
16	A zero dividing error has occurred.	○	●	○	No	No
17	A momentary power interruption has occurred.	○	●	○	No	No
18	An EEPROM for back-up cannot be read/written properly.	○	●	○	No	No
19	Disconnection of the open-air temperature detection thermistor connector	○	●	○	No	Yes

NOTE : ○: ON ⊙: Blinks ●: OFF

10.4 SELF-TEST/TEST PRINTING

10.4.1 Self-test/Test Printing Operation Example

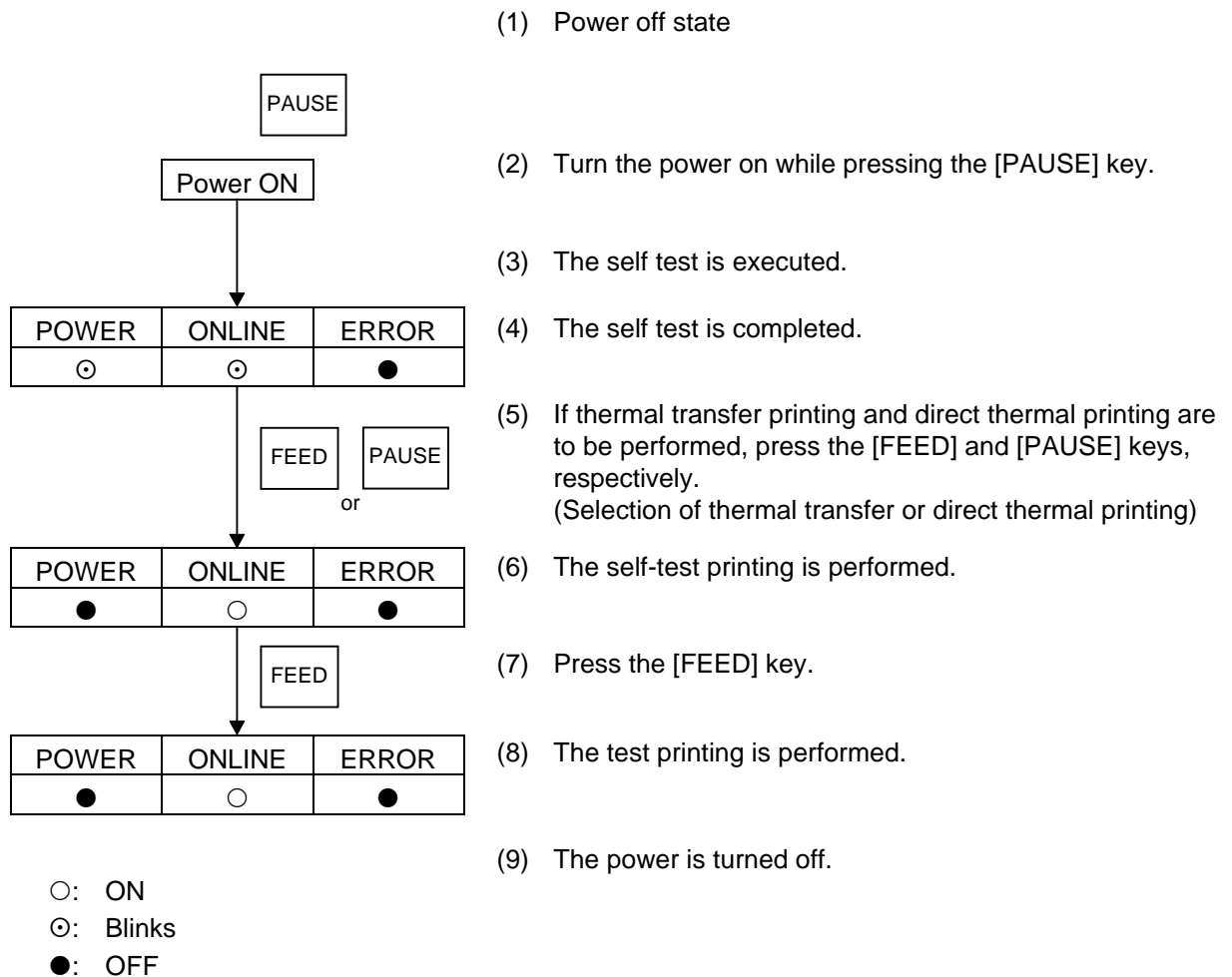

NOTES:

1. Printing conditions: 76 mm of label length, no sensor used, 2"/sec, one sheet to print, batch issue
2. If an error occurs during printing, the printer indicates the ERROR LED and stops printing. The error state is cleared by pressing the [PAUSE] key, and the printer returns to the state before the selection of thermal transfer/direct thermal printing. After the error is cleared, the printer does not reprint automatically.
3. Even if the printer enters an automatic forward feed standby state in the online mode, the automatic reverse feed is not performed when the test printing is started.
4. Even if the printer enters an automatic forward feed standby state in the online mode, the automatic reverse feed is not performed after the self-test printing is performed.
5. If the head is opened or closed, the automatic forward feed standby is not performed.

10.4.2 Self-test Items

(1) Maintenance Counter/Various Parameters Printouts

① Maintenance Counter

- Total label distance covered (cannot be cleared)
- Label distance covered
- Print distance
- Cut count
- Ribbon motor drive time
- RS-232C hardware error count
- System error count
- Momentary power interruption count

② Various Parameters

[Values programmed on the PC]

- Feed fine adjustment value
- Cut position (or strip position) fine adjustment value
- Back feed fine adjustment value
- Print density fine adjustment value (Thermal transfer)
- Print density fine adjustment value (Direct thermal)
- Ribbon motor drive voltage fine adjustment
- Print shrinkage correction value setting

[Values programmed using the external keyboard]

- Feed fine adjustment value
- Cut position (or strip position) fine adjustment value
- Back feed fine adjustment value
- Print density fine adjustment value (Thermal transfer)
- Print density fine adjustment value (Direct thermal)
- Ribbon motor drive voltage fine adjustment
- Print shrinkage correction value setting
- Reflective sensor manual threshold fine adjustment value
- Transmissive sensor manual threshold fine adjustment value
- X-coordinate fine adjustment value
- Character code type
- Font "0"
- Control code type
- Code 5CH selection ("¥" or "\")
- Kanji code type
- Transmission control protocol
- Strip status selection
- Euro code
- Stacker use selection
- TrueType font block setting
- Bit map writable character block setting
- PC save block setting

[Values set by DIP SW]

- Communication speed
- Parity

(2) Automatic Self-test

① Memory Check

- Program area (version, part number, checksum)
- Boot area checksum
- Font area checksum
- Kanji ROM checksum
- EEPROM check
- DRAM check

② Sensor Check

- Strip sensor
- Thermal head open sensor
- Cutter home position sensor
- Ribbon rewind motor sensor
- Back tension motor sensor
- Thermal head temperature sensor
- Open-air temperature sensor
- Reflective sensor
- Transmissive sensor
- Thermal head resistance rank
- Reflective/transmissive sensor status without paper

③ Switch Check

- DIP SW

④ Loop Back Check

- DIN loop back check
- Expansion I/O loop back check

10.4.3 Self-test Results Printout Samples

(1) Maintenance Counter/Various Parameters Printout

TL FEED	0.0km	[PC]	
FEED	0.0km	FEED	+0.0mm
PRINT	0.0km	CUT	+0.0mm
CUT	64	BACK	+0.0mm
RIBBON	0h	TONE(T)	+0step
232C ERR	255	TONE(D)	+0step
SYS ERR	0	[KEY]	
PW FAIL	0	FEED	+0.0mm
PRINT SPEED		CUT	+0.0mm
[PC]	+1.0%	BACK	+0.0mm
[KEY]	+0.0%	TONE(T)	+0step
X ADJ.	+0.0mm	TONE(D)	+0step
RIBN ADJ.	[PC]+0	+0 [KEY]	+0 +0
FONT	[PC-850]	[0]	[¥]
SPEED	[9600]	PARITY	[EVEN]
CONTROL	[XON/XOFF]		
CODE	[AUTO]	STATUS	[OFF]
THRESHOLD R	1.0V	T	0.7V
KANJI	[TYPE1]	EURO CODE	FFH
STACKER	[OFF]	TT BLOCK	[0]
GAIJI BLK	[15]	PCSAV BLK	[0]

(2) Automatic Self-test Printout

PROGRAM	V1.3	FMRM0050901	:EC00
			(5300)
FONT	CA00		
KANJI	9D00		
EEPROM	OK		
DRAM	2048KB		
SENSOR1	00000000,00010110		
SENSOR2	[H]28°C [A]28°C		
	[R]3.9V [T]1.6V		
	[RANK]10		
PE LV.	[R]1.8V [T]4.5V		
DIP SW	00010110		
DIN	NG		
EXP.I/O	NG		

NOTE: Print Conditions: 76 mm of label length, no sensor used, 2"/sec, one sheet to print, batch issue.

“o” cannot be printed correctly in some character code types.

10.4.4 Self-test Printout Contents

(1) Maintenance Counter

Item	Contents	Range
TL FEED	Total label distance covered (cannot be cleared)	0.0 to 3200.0 km
FEED	Label distance covered	0.0 to 200.0 km
PRINT	Print distance	0.0 to 200.0 km
CUT	Cut count	0 to 1000000
RIBBON	Ribbon motor drive time	0 to 2000 hours
232C ERR	RS-232C hardware error count	0 to 255
SYS ERR	System error count	0 to 15
PW FAIL	Momentary power interruption count	0 to 15

Maintenance Counter	Count Conditions
Total label distance covered Label distance covered	Counts when the paper feed motor is driven to perform paper feed, print and eject operations. (Counts also during a reverse feed operation.) When the power is off, a label distance of 8.2 m or less is rounded down and backed up as 0.0 m. If a label distance is less than 0.5 km, it is printed as 0.0 km.
Print distance	Counts while printing. (Counting is not performed during eject and reverse feed operations.) When the power is off, a label distance of 8.2 m or less is rounded down and backed up as 0.0 m. If a print distance is less than 0.5 km, it is printed as 0.0 km.
Cut count	Every cut operation is counted. When the power is off, a cut count of 31 or less is rounded down and backed up as 0.
Ribbon motor drive time	Counts when the ribbon motor is driven to perform paper feed, print and eject operations. (Counts also during a reverse feed operation.) When the power is off, a drive time of 32 seconds or less is rounded down and backed up as 0.
RS-232C hardware error count	Counts when a parity, overrun, or framing error occurs. * When data of several bytes is transmitted continuously, counting is performed per byte.
System error count	Counts when a zero-dividing error occurs or non-defined command is fetched.
Momentary power interruption count	Counts when a momentary power interruption occurs.

(2) Various Parameters Check Contents

Item	Contents	Remarks
[PC] FEED	Feed fine adjustment	-10.0 mm to +10.0 mm
CUT	Cut position (or strip position) fine adjustment	-10.0 mm to +10.0 mm
BACK	Back feed fine adjustment	-9.9 mm to +9.9 mm
TONE (T)	Print density fine adjustment (thermal transfer)	-10 to +10 step
TONE (D)	Print density fine adjustment (direct thermal)	-10 to +10 step
RIBN ADJ.	Ribbon motor drive voltage fine adjustment	-15 to +0 step
[KEY] FEED	Feed fine adjustment	-10.0 mm to +10.0 mm
CUT	Cut position (or strip position) fine adjustment	-10.0 mm to +10.0 mm
BACK	Back feed fine adjustment	-9.9 mm to +9.9 mm
TONE (T)	Print density fine adjustment (thermal transfer)	-10 to +10 step
TONE (D)	Print density fine adjustment (direct thermal)	-10 to +10 step
RIBN ADJ.	Ribbon motor drive voltage fine adjustment	-15 to 0 step
X ADJ.	X-coordinate fine adjustment	-99.5 mm to +99.5 mm
FONT	Character code selection	PC-850: PC-850 PC-8: PC-8 PC-852: PC-852 PC-857: PC-857 PC-851: PC-851 PC-855: PC-855 PC-1250: PC-1250 PC-1251: PC-1251 PC-1252: PC-1252 PC-1253: PC-1253 PC-1254: PC-1254 PC-1257: PC-1257 LATIN9: LATIN9 ARABIC: ARABIC
	Font "0" selection	0 : No slash used Ø : Slash used
	Code 5CH selection ("¥" or "\")	¥: ¥ \: \
SPEED	Transmission speed	2400: 2400 bps 4800: 4800 bps 9600: 9300 bps 19200: 19200 bps
PARITY	Parity	NONE: NONE parity EVEN: EVEN parity

Item	Contents	Remarks
CONTROL	Transmission control method	XON/XOFF: XON/XOFF protocol (No XON output at power on time, no XOFF output at power off time) READY/BUSY: READY/BUSY (DTR) protocol (No XON output at power on time, no XOFF output at power off time) XON+READY AUTO: XON/XOFF+READY/BUSY (DTR) protocol (XON output at power on time, XOFF output at power off time) XON/XOFF AUTO: XON/XOFF protocol (XON output at power on time, XOFF output at power off time) READY/BUSY RTS: READY/BUSY (RTS) protocol (No XON output at power on time, no XOFF output at power off time)
CODE	Control code type	AUTO: Automatic selection ESC: ESC LF NUL method { }: { } method
STATUS	Strip status selection	OFF: Without strip status ON: With strip status
THRESHOLD R	Reflective sensor manual threshold fine adjustment value	0.0 V to 4.0 V
THRESHOLD T	Transmissive sensor manual threshold fine adjustment value	0.0 V to 4.0 V
KANJI	Kanji code type	TYPE1: For Windows codes TYPE2: For original codes
PRINT SPEED	Print shrinkage correction value	-10.0% to +10.0%
EURO CODE	Euro code	20H to FFH
STACKER	Stacker use selection	ON: Used OFF: Not used
TT BLOCK	TrueType font block	0 to 15
GAIJI BLK	Bit map writable character block	0 to 15
PCSAV BLK	PC save block	0 to 15

(3) Memory Check Contents

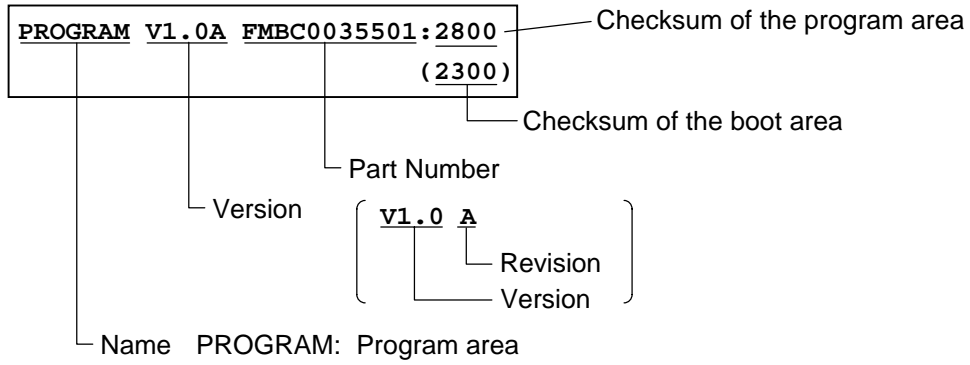

FONT 0000

Font area

KANJI 0000

Kanji ROM

<Supplementary Explanation>

- The last two digits of the checksum are usually 0.
- The checksum should be calculated whether the Kanji ROM is installed or not. However, when any data in the four Kanji ROMs is not proper, the checksum is not calculated and "0000" is printed.
- The version, part number, and checksum vary according to software version.

EEPROM OK

OK: Data in the check area can be properly read/written.
NG: Data in the check area cannot be properly read/rewritten.
Back-up memory (EEPROM)

DRAM 2048KB

All displayed data can be read/written.
Memory for the system and drawing

(4) Sensor Check Contents

① Sensor 1

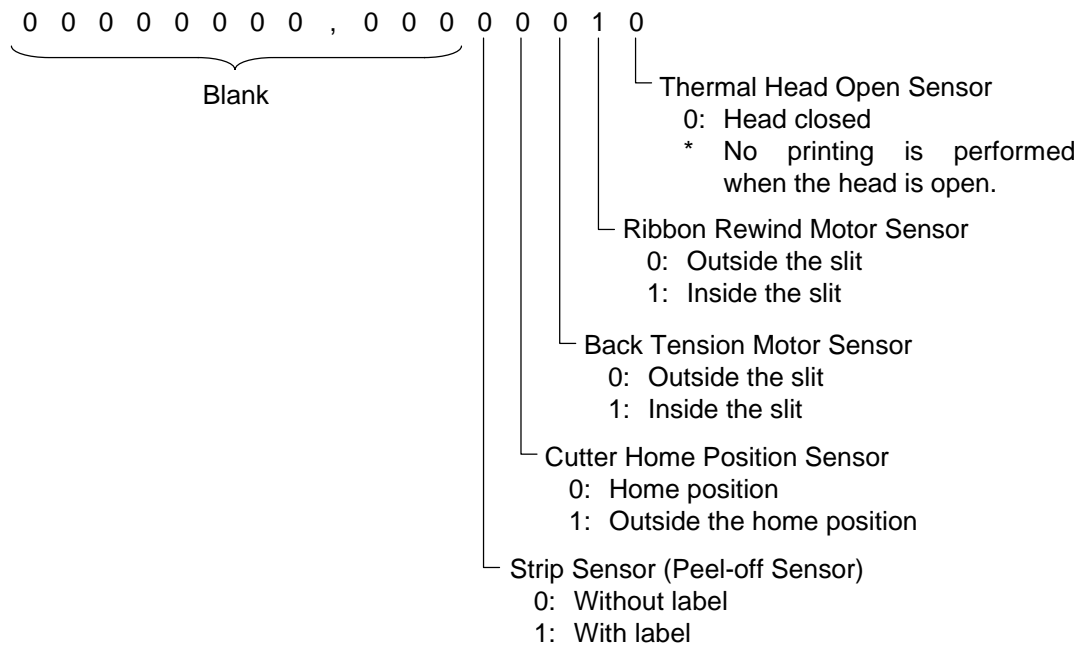

② Sensor 2

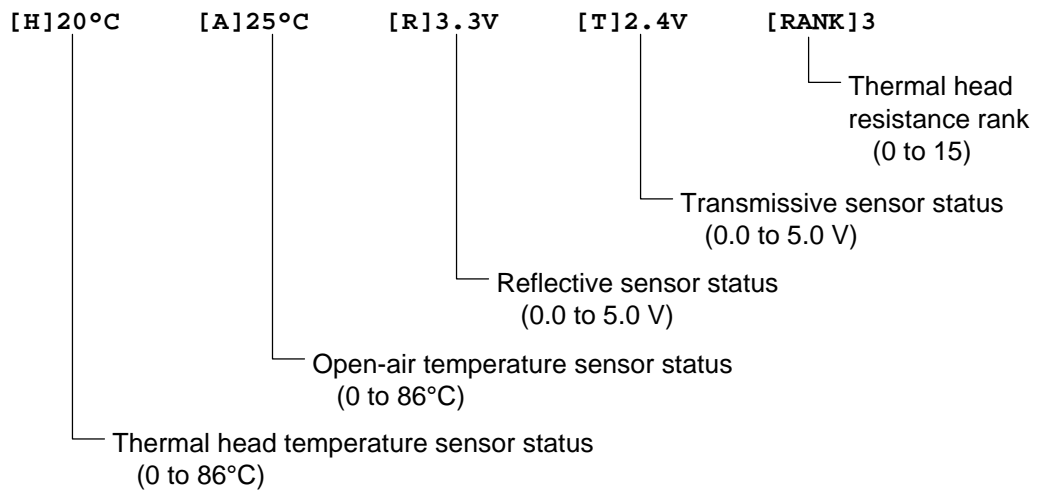

* Thermal Head Resistance Rank

Resistance Rank	Average Resistance (ohm)
0	1731 to 1759
1	1703 to 1730
2	1674 to 1702
3	1645 to 1673
4	1617 to 1644
5	1588 to 1616
6	1559 to 1587
7	1531 to 1558
8	1502 to 1530
9	1473 to 1501
10	1444 to 1472
11	1416 to 1443
12	1387 to 1415
13	1358 to 1386
14	1330 to 1357
15	1301 to 1329

* Reflective/transmissive sensor status without paper

[R] 1.8V [T] 4.5V

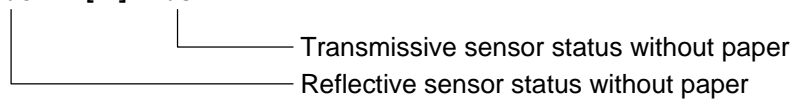

(5) Switch Check Contents

No.: 87654321

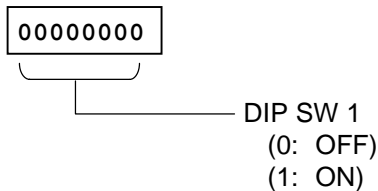

(6) Loop Back Check By Using DIN Cable

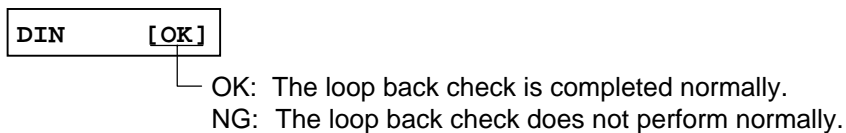

(7) Expansion I/O Loop Back Check

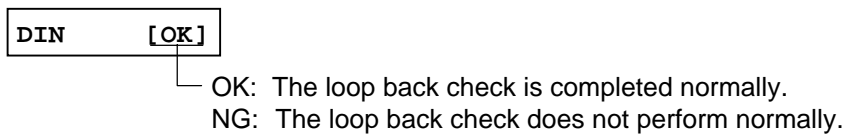

10.4.5 Test Print Samples

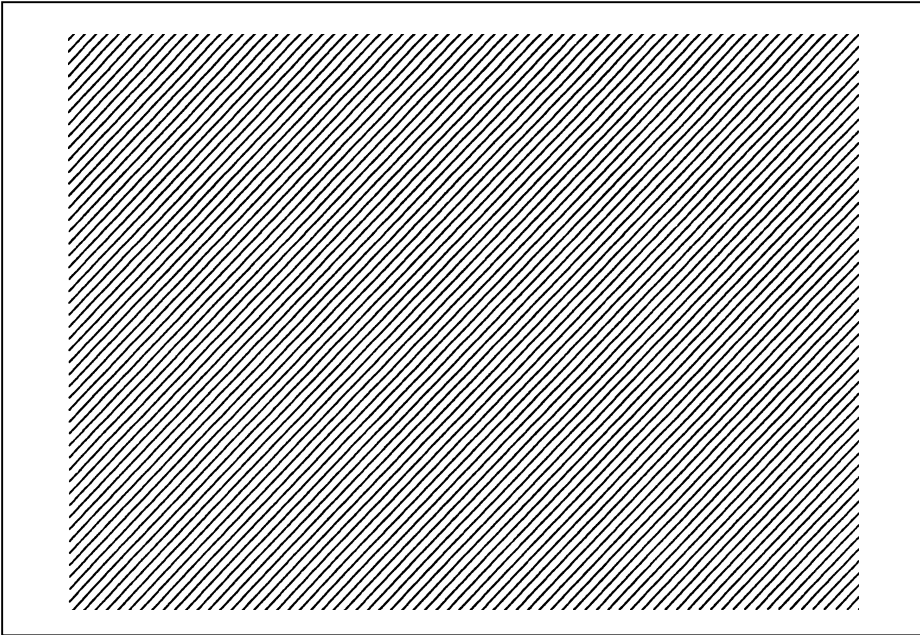

3-dot slant line printout

10.5 SENSOR ADJUSTMENT

10.5.1 Sensor Adjustment Operation Example

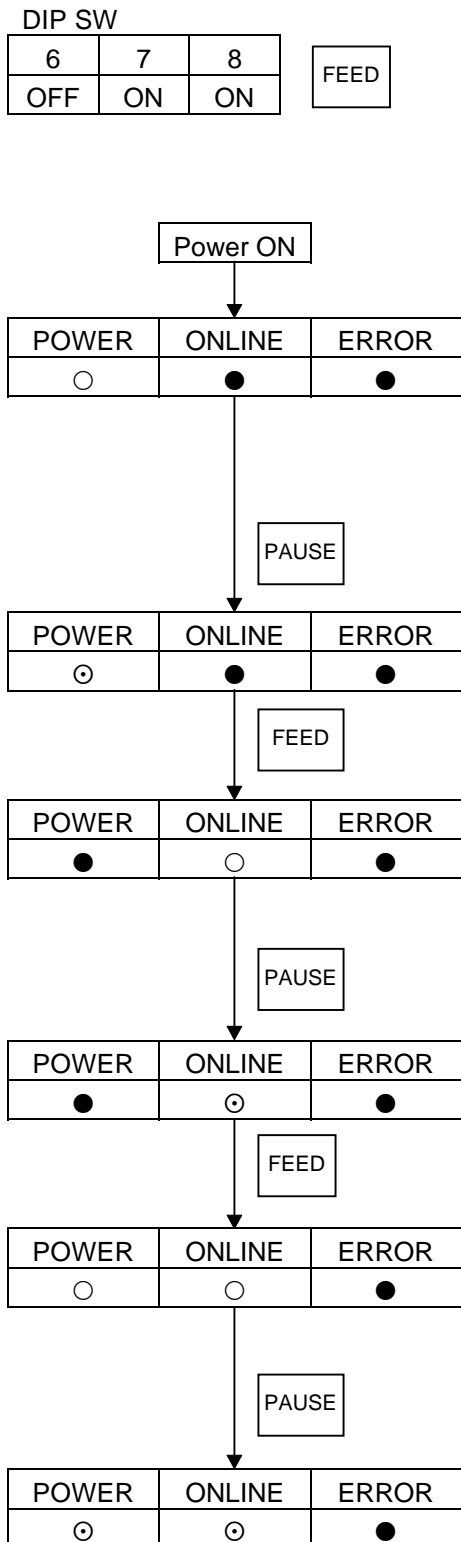

- (1) Power off state
- (2) Set the DIP SW to the sensor adjustment mode.
Turn the power on while pressing the [FEED] key.
- (3) The printer enters the sensor adjustment mode.
- (4) Reflective sensor adjustment
* Load tag paper.
(The black mark should not cover the sensor.)
- (5) Press the [PAUSE] key for 3 seconds or more.
- (6) When the reflective sensor adjustment is completed, the POWER LED blinks.
- (7) Transmissive sensor adjustment
* Remove the label from the label paper and load the backing paper. (The label should not cover the sensor.)
- (8) Press the [PAUSE] key for 3 seconds or more.
- (9) When the transmissive sensor adjustment is completed, the POWER LED blinks.
- (10) The reflective/transmissive sensor fine adjustment is stored. (The sensor status without paper is stored.)
* Remove any paper covering the sensor.
- (11) Press the [PAUSE] key for 3 seconds or more.
- (12) After the reflective/transmissive sensor fine adjustment has been stored, the ONLINE LED blinks.
- (13) The power is turned off.

○: ON
⊙: Blinks
●: OFF

10.6 THRESHOLD SETTING (PREPRINTED LABEL)

10.6.1 Outline of Threshold Setting

When a label is printed, the printer detects the gap between the labels using the transmissive sensor, and corrects the print position automatically to obtain a constant print position. When a preprinted label is used, some inks may prevent proper positioning correction. Also when a perforated label is used, the same problem will occur. If this is the case, determine the transmissive sensor threshold by key operation and store the value in the non-volatile memory (EEPROM).

A constant print position on the preprinted labels can be obtained since the print position is always corrected using the threshold stored in the non-volatile memory (EEPROM) by selecting "3: Transmissive Sensor (when using a manual threshold value)" for the sensor type of the Issue Command.

When a label is printed by detecting the black mark on the back of the label, the reflective rate variation of a place other than the black mark (for example, perforation) may prevent the proper positioning correction. In this case, determine the reflective sensor threshold by key operation and store the value in the non-volatile memory (EEPROM).

A constant print position can also be obtained when printing on a tag since the print position is always corrected using the threshold stored in the non-volatile memory (EEPROM) by selecting "4: Reflective Sensor (when using a manual threshold value)" for the sensor type of the Issue Command.

10.6.2 Threshold Setting Operation Example

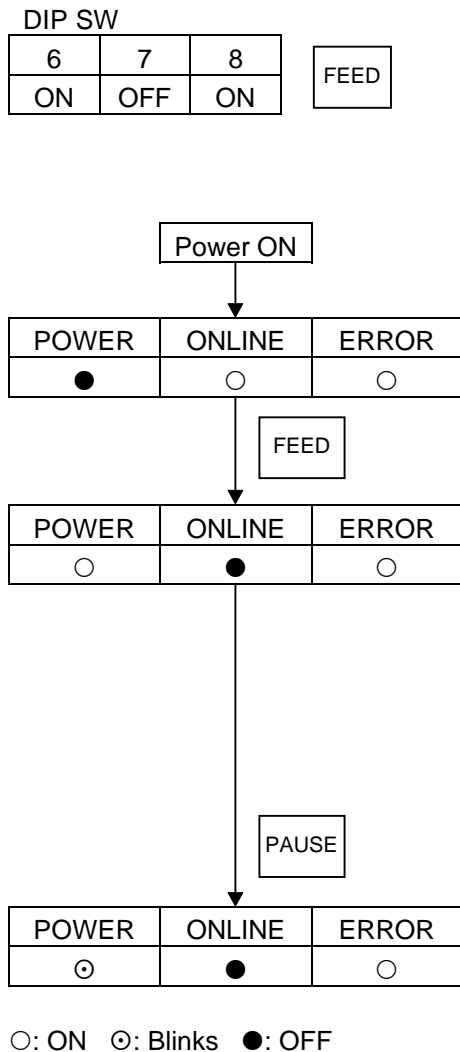

- (1) Power off state
- (2) Set the DIP SW to the threshold setting mode.
Turn the power on while pressing the [FEED] key.
- (3) The printer enters the transmissive sensor threshold manual setting mode.
- (4) Press the [FEED] key.
- (5) The printer enters the reflective sensor threshold manual setting mode.
Every time the [FEED] key is pressed, the sensor is changed between reflective and transmissive.
Load the preprinted label.
(No particular positioning is required.)
- (6) Continue pressing the [PAUSE] key.
- (7) The printer feeds the label until the [PAUSE] key is released.
- (8) When the [PAUSE] key is released after more than 1.5 sheets of the label are fed, the printer stops feeding the label. (Threshold setting for the selected sensor is completed. If the selected sensor is the transmissive sensor, the ONLINE LED blinks.)
- (9) The power is turned off.

<Supplementary Explanation>

- (1) When the threshold is set, 1.5 sheets of the label or more should be fed. (If the label is not fed by the above amount, the threshold may not be properly set. In this case, reprogramming is required.)
- (2) If the [PAUSE] key is pressed for 3 seconds or more in a head-up state, the [PAUSE] key is invalid.
- (3) During a label feed, an error including the paper end or cutter error is not detected.
- (4) When the proper print position is not obtained after threshold setting, the transmissive (or reflective) sensor may be improperly adjusted. In this case, readjust the transmissive (or reflective) sensor, and set the threshold.

When the backing paper of the label is too thick, the transmissive (or reflective) sensor should be readjusted.

In addition, make sure that "3: Transmissive sensor (when using a manual threshold value)" or "4: Reflective sensor (when using a manual threshold value)" is selected for sensor type of the Feed Command and the Issue Command.

When the proper print position is not obtained even though the above adjustment and threshold setting were attempted, change the transmissive (or reflective) sensor manual threshold fine adjustment value. For details, refer to the descriptions for parameters "kk" and "ll" in "6.29 Parameter Set Command" in this specification, and (13) and (14) in "6.3.2 Setting Contents" in the Key Operation Specification for KB-80 (TAA-1091).

10.7 RAM CLEAR OPERATION EXAMPLE

10.7.1 RAM Clear Operation Example

DIP SW

Parameter clear

6	7	8
ON	ON	ON

Maintenance counter clear

6	7	8
OFF	OFF	ON



- (1) Power off state
- (2) Set the DIP SW to the RAM clear mode
Turn the power on while pressing the [FEED] and [PAUSE] keys.

Power ON

POWER	ONLINE	ERROR
○	○	○

PAUSE

POWER	ONLINE	ERROR
⊙	⊙	⊙

- (3) The printer enters the RAM clear mode.
- (4) RAM clear is executed.
- (5) RAM clear is completed.
- (6) The power is turned off.

- : ON
- ⊙: Blinks
- : OFF

10.7.2 RAM Clear Contents

(1) Supplementary Explanation

- After RAM clear is complete, be sure to turn off the power.
- The total label distance covered, sensor adjustment value and the contents of flash memory are not cleared by the RAM clear operation.

(2) Initial Values After Maintenance Counter Clear

Item	Initial Value
Label distance covered	0 km
Print distance	0 km
Cut count	0
Ribbon motor drive time	0 hour
RS-232C hardware error count	0
System error count	0
Momentary power interruption count	0

(3) Initial Values After Parameter Clear

Parameter	Initial Value
Feed fine adjustment (PC)	0 mm
Cut position (or strip position) fine adjustment (PC)	0 mm
Back feed fine adjustment (PC)	0 mm
Print density fine adjustment: Thermal transfer print mode (PC)	0
Print density fine adjustment: Direct thermal print mode (PC)	0
Ribbon motor drive voltage fine adjustment (PC)	0
Feed fine adjustment (Keyboard)	0 mm
Cut position (or strip position) fine adjustment (Keyboard)	0 mm
Back feed fine adjustment (Keyboard)	0 mm
Print density fine adjustment: Thermal transfer print mode (Keyboard)	0
Print density fine adjustment: Direct thermal print mode (Keyboard)	0
Ribbon motor drive voltage fine adjustment (Keyboard)	0
X-coordinate fine adjustment	0 mm
Character code selection	PC-850
Font "0" selection	"0" without slash mark
Code 5CH selection	When RAM clear is performed, "\" if the Kanji ROM has not been installed "¥" if the Kanji ROM has been installed

Parameter	Initial Value
Transmission control method	XON/XOFF+READY/BUSY protocol (DTR protocol) (XON output at a power on time, XOFF output at a power off time)
Control code type	Automatic selection
Status response	With
Strip status selection	OFF
Reflective sensor manual threshold fine adjustment value	1.0 V
Transmissive sensor manual threshold fine adjustment value	0.7 V
Label pitch	76.2 mm
Effective print length	74.2 mm
Effective print width	105.7 mm
Sensor type	Transmissive sensor
Feed speed	2"/sec
Issue mode	Batch (without cutting)
PC-save automatic call	With
Kanji code	TYPE 1
Print shrinkage correction value (PC)	0%
Print shrinkage correction value (Keyboard)	0%
Euro code	B0H
TrueType font block	Not initialized
Bit map writable character block	Not initialized
PC save block	Not initialized

11. CHARACTER CODE TABLE

The followings are the character code tables. However, the characters which can be printed are different according to the character type. For the character which can be printed, refer to the print sample described below. Code 5CH depends on the setting for the selection of “¥” or “\”.

11.1 TIMES ROMAN, HELVETICA, LETTER GOTHIC, PRESTIGE ELITE, COURIER

(1) PC-850

	0	1	2	3	4	5	6	7	8	9	A	B	C	D	E	F
0			0	@	P	`	p	Ç	É	á	€			ø	Ó	-
1			!	1	A	Q	a	q	ü	æ	í			Ð	ß	±
2			"	2	B	R	b	r	é	Æ	ó			Ê	Ô	=
3			#	3	C	S	c	s	â	ô	ú			Ë	Ò	¾
4			\$	4	D	T	d	t	ä	ö	ñ			È	õ	¶
5			%	5	E	U	e	u	à	ò	Ñ	Á		1	Ö	§
6			&	6	F	V	f	v	â	û	ª	Â	ã	í	µ	÷
7			'	7	G	W	g	w	ç	ù	º	À	Ã	î	þ	,
8			(8	H	X	h	x	ê	ÿ	¿	©		ï	ƒ	°
9)	9	I	Y	i	y	ë	Ï	®				Ú	¨
A			*	:	J	Z	j	z	è	Ü	¬				Û	•
B			+	;	K	[k	{	ï	Ø	½				Ù	1
C			,	<	L	\	l		î	£	¼				ý	3
D			-	=	M]	m	}	ì	∅	¡	¢		ı	Ý	2
E			.	>	N	^	n	~	Ä	x	«	¥		ì	'	■
F			/	?	O	_	o	¸	Å	f	»		¤		'	

(2) PC-8

	0	1	2	3	4	5	6	7	8	9	A	B	C	D	E	F
0			0	@	P	`	p	Ç	É	á	€				α	≡
1			!	1	A	Q	a	q	ü	æ	í				β	±
2			"	2	B	R	b	r	é	Æ	ó				Γ	≥
3			#	3	C	S	c	s	â	ô	ú				π	≤
4			\$	4	D	T	d	t	ä	ö	ñ				Σ	∫
5			%	5	E	U	e	u	à	ò	Ñ				σ	∫
6			&	6	F	V	f	v	â	û	ª				μ	÷
7			'	7	G	W	g	w	ç	ù	º				τ	≈
8			(8	H	X	h	x	ê	ÿ	¿				Φ	°
9)	9	I	Y	i	y	ë	Ï	¬				Θ	•
A			*	:	J	Z	j	z	è	Ü	¬				Ω	•
B			+	;	K	[k	{	ï	∅	½				δ	√
C			,	<	L	\	l		î	£	¼				∞	n
D			-	=	M]	m	}	ì	¥	¡				∅	2
E			.	>	N	^	n	~	Ä	Pt	«				ε	■
F			/	?	O	_	o	¸	Å	∫	»				∩	

(3) PC-852

	0	1	2	3	4	5	6	7	8	9	A	B	C	D	E	F
0				0	@	P	`	p	Ç	É	á	€			Ó	-
1			!	1	A	Q	a	q	ü		í			Đ	ß	
2			"	2	B	R	b	r	é		ó				Ô	
3			#	3	C	S	c	s	â	ô	ú			Ë		
4			\$	4	D	T	d	t	ä	ö						
5			%	5	E	U	e	u				Á				§
6			&	6	F	V	f	v				Â		Í		÷
7			'	7	G	W	g	w	ç					Î		°
8			(8	H	X	h	x								°
9)	9	I	Y	i	y	ë	Ö					Ú	¨
A			*	:	J	Z	j	z		Ü						•
B			+	;	K	[k	{								
C			,	<	L	\	l		î						Ý	
D			-	=	M]	m	}							Ÿ	
E			.	>	N	^	n	~	Ä	x	«					■
F			/	?	O	_	o	⌘			»		▫			

(4) PC-857

	0	1	2	3	4	5	6	7	8	9	A	B	C	D	E	F
0				0	@	P	`	p	Ç	É	á	€		º	Ó	-
1			!	1	A	Q	a	q	ü	æ	í			ª	ß	±
2			"	2	B	R	b	r	é	Æ	ó			Ë	Ô	
3			#	3	C	S	c	s	â	ô	ú			Ë	Ò	¼
4			\$	4	D	T	d	t	ä	ö	ñ			È	õ	¶
5			%	5	E	U	e	u	à	ò	Ñ	Á			Õ	§
6			&	6	F	V	f	v	å	û		Â	ã	Í	µ	÷
7			'	7	G	W	g	w	ç	ù		À	Ã	Î		·
8			(8	H	X	h	x	ê		¿	©		Ï	x	°
9)	9	I	Y	i	y	ë	Ö	®				Ú	¨
A			*	:	J	Z	j	z	è	Ü	¬				Û	•
B			+	;	K	[k	{	ï	ø	½				Ù	1
C			,	<	L	\	l		î	£	¼				ì	3
D			-	=	M]	m	}		Ø	ı	¢		ı	ÿ	2
E			.	>	N	^	n	~	Ä		«	¥		ì		■
F			/	?	O	_	o	⌘	Å		»		▫		'	

(5) PC-851

	0	1	2	3	4	5	6	7	8	9	A	B	C	D	E	F
0				0	@	P	`	p	Ç			€				
1			!	1	A	Q	a	q	ü							±
2			"	2	B	R	b	r	é							
3			#	3	C	S	c	s	â	ô						
4			\$	4	D	T	d	t	ä	ö						
5			%	5	E	U	e	u	à							§
6			&	6	F	V	f	v		û						
7			'	7	G	W	g	w	ç	ù						°
8			(8	H	X	h	x	ê							°
9)	9	I	Y	i	y	ë	Ö						¨
A			*	:	J	Z	j	z	è	Ü						
B			+	;	K	[k	{	ï		½					
C			,	<	L	\	l		î	£						
D			-	=	M]	m	}								
E			.	>	N	^	n	~	Ä		«					■
F			/	?	O	_	o	⌘			»					

(6) PC-855

	0	1	2	3	4	5	6	7	8	9	A	B	C	D	E	F
0				0	@	P	`	p				€				
1			!	1	A	Q	a	q								
2			"	2	B	R	b	r								
3			#	3	C	S	c	s								
4			\$	4	D	T	d	t								
5			%	5	E	U	e	u								
6			&	6	F	V	f	v								
7			'	7	G	W	g	w								
8			(8	H	X	h	x								
9)	9	I	Y	i	y								
A			*	:	J	Z	j	z								
B			+	;	K	[k	{								
C			,	<	L	\	l									
D			-	=	M]	m	}								§
E			.	>	N	^	n	~			«					■
F			/	?	O	_	o	⌘			»		¤			

(7) PC-1250

	0	1	2	3	4	5	6	7	8	9	A	B	C	D	E	F
0				0	@	P	`	p				€				
1			!	1	A	Q	a	q				±	Á		á	
2			"	2	B	R	b	r					Â		â	
3			#	3	C	S	c	s						Ó		ó
4			\$	4	D	T	d	t			α	´	Ä	Ö	ä	ö
5			%	5	E	U	e	u				μ				
6			&	6	F	V	f	v			¡	¶		Ö		ö
7			'	7	G	W	g	w			§	·	Ç	x	ç	÷
8			(8	H	X	h	x			¨	¸				
9)	9	I	Y	i	y			©		É		é	
A			*	:	J	Z	j	z						Ú		ú
B			+	;	K	[k	{			«	»	Ë		ë	
C			,	<	L	\	l				¬			Ü		ü
D			-	=	M]	m	}					Í	Ý	í	ý
E			.	>	N	^	n	~			®		Î		î	
F			/	?	O	_	o	⌘						ß		

(8) PC-1251

	0	1	2	3	4	5	6	7	8	9	A	B	C	D	E	F
0				0	@	P	`	p				€				
1			!	1	A	Q	a	q				±				
2			"	2	B	R	b	r								
3			#	3	C	S	c	s								
4			\$	4	D	T	d	t			α					
5			%	5	E	U	e	u				μ				
6			&	6	F	V	f	v			¡	¶				
7			'	7	G	W	g	w			§	·				
8			(8	H	X	h	x								
9)	9	I	Y	i	y			©					
A			*	:	J	Z	j	z								
B			+	;	K	[k	{			«	»				
C			,	<	L	\	l				¬					
D			-	=	M]	m	}								
E			.	>	N	^	n	~			®					
F			/	?	O	_	o	⌘								

(9) PC-1252

	0	1	2	3	4	5	6	7	8	9	A	B	C	D	E	F
0			0	@	P	`	p				€	À	Ð	à	ð	
1		!	1	A	Q	a	q				ı	±	Á	Ñ	á	ñ
2		"	2	B	R	b	r				¢	²	Â	Ò	â	ò
3		#	3	C	S	c	s	<i>f</i>			£	³	Ã	Ó	ã	ó
4		\$	4	D	T	d	t				¤	'	Ä	Ö	ä	ö
5		%	5	E	U	e	u				¥	μ	Å	Õ	å	õ
6		&	6	F	V	f	v				ı	¶	Æ	Ö	æ	ö
7		'	7	G	W	g	w				§	·	Ç	x	ç	÷
8		(8	H	X	h	x	^	~	¨	,	È	Ø	è	ø	
9)	9	I	Y	i	y			©	¹	É	Ù	é	ù	
A		*	:	J	Z	j	z			ª	º	Ê	Ú	ê	ú	
B		+	;	K	[k	{			«	»	Ë	Û	ë	û	
C		,	<	L	\	l				¬	¼	Ì	Ü	ì	ü	
D		-	=	M]	m	}				½	Í	Ý	í	ý	
E		.	>	N	^	n	~			®	¾	Î	Þ	î	þ	
F		/	?	O	_	o	⌘				¿	Ï	ß	ï	ÿ	

(10) PC-1253

	0	1	2	3	4	5	6	7	8	9	A	B	C	D	E	F
0			0	@	P	`	p				€					
1		!	1	A	Q	a	q				±					
2		"	2	B	R	b	r				²					
3		#	3	C	S	c	s	<i>f</i>			£	³				
4		\$	4	D	T	d	t				¤					
5		%	5	E	U	e	u				¥	μ				
6		&	6	F	V	f	v				ı	¶				
7		'	7	G	W	g	w				§	·				
8		(8	H	X	h	x				¨					
9)	9	I	Y	i	y			©						
A		*	:	J	Z	j	z			ª						
B		+	;	K	[k	{			«	»					
C		,	<	L	\	l				¬						
D		-	=	M]	m	}				½					
E		.	>	N	^	n	~			®						
F		/	?	O	_	o	⌘									

(11) PC-1254

	0	1	2	3	4	5	6	7	8	9	A	B	C	D	E	F
0			0	@	P	`	p				€	À		à		
1		!	1	A	Q	a	q				ı	±	Á	Ñ	á	ñ
2		"	2	B	R	b	r				¢	²	Â	Ò	â	ò
3		#	3	C	S	c	s	f			£	³	Ã	Ó	ã	ó
4		\$	4	D	T	d	t				¤	'	Ä	Ô	ä	ô
5		%	5	E	U	e	u				¥	μ	Å	Õ	å	õ
6		&	6	F	V	f	v				ı	¶	Æ	Ö	æ	ö
7		'	7	G	W	g	w				§	·	Ç	x	ç	÷
8		(8	H	X	h	x	^	~	¨	,	È	Ø	è	ø	
9)	9	I	Y	i	y			©	¹	É	Ù	é	ù	
A		*	:	J	Z	j	z			ª	º	Ê	Ú	ê	ú	
B		+	;	K	[k	{			«	»	Ë	Û	ë	û	
C		,	<	L	\	l				¬	¼	Ì	Ü	ì	ü	
D		-	=	M]	m	}				½	Í		í	¹	
E		.	>	N	^	n	~			®	¾	Î		î		
F		/	?	O	_	o	⌘				¿	Ï	ß	ï	ÿ	

(12) PC-1257

	0	1	2	3	4	5	6	7	8	9	A	B	C	D	E	F
0			0	@	P	`	p				€					
1		!	1	A	Q	a	q				±					
2		"	2	B	R	b	r				¢	²				
3		#	3	C	S	c	s				£	³		Ó		ó
4		\$	4	D	T	d	t				¤	'	Ä		ä	
5		%	5	E	U	e	u				¥	μ	Å	Õ	å	õ
6		&	6	F	V	f	v				ı	¶		Ö		ö
7		'	7	G	W	g	w				§	·		x		÷
8		(8	H	X	h	x				Ø	ø				
9)	9	I	Y	i	y			©	¹	É		é		
A		*	:	J	Z	j	z									
B		+	;	K	[k	{			«	»					
C		,	<	L	\	l				¬	¼		Ü		ü	
D		-	=	M]	m	}		¨	-		½				
E		.	>	N	^	n	~			®	¾					
F		/	?	O	_	o	⌘				Æ	æ		ß		

(13) LATIN9

	0	1	2	3	4	5	6	7	8	9	A	B	C	D	E	F
0				0	@	P	`	p				€	À	Ð	à	ð
1			!	1	A	Q	a	q			ı	±	Á	Ñ	á	ñ
2			"	2	B	R	b	r			¢	²	Â	Ò	â	ò
3			#	3	C	S	c	s			£	³	Ã	Ó	ã	ó
4			\$	4	D	T	d	t			€		Ä	Ö	ä	ö
5			%	5	E	U	e	u			¥	μ	Å	Õ	å	õ
6			&	6	F	V	f	v				¶	Æ	Ö	æ	ö
7			'	7	G	W	g	w			§	·	Ç	x	ç	÷
8			(8	H	X	h	x					È	Ø	è	ø
9)	9	I	Y	i	y			©	¹	É	Ù	é	ù
A			*	:	J	Z	j	z			ª	º	Ê	Ú	ê	ú
B			+	;	K	[k	{			«	»	Ë	Û	ë	û
C			,	<	L	\	l				¬		Ì	Ü	ì	ü
D			-	=	M]	m	}					Í	Ý	í	ý
E			.	>	N	^	n	~			®		Î	Þ	î	þ
F			/	?	O	_	o	⌘				¿	Ï	ß	ï	ÿ

(14) ARABIC

	0	1	2	3	4	5	6	7	8	9	A	B	C	D	E	F
0				0	@	P	`	p				€				
1			!	1	A	Q	a	q								
2			"	2	B	R	b	r								
3			#	3	C	S	c	s								
4			\$	4	D	T	d	t								
5			%	5	E	U	e	u								
6			&	6	F	V	f	v								
7			'	7	G	W	g	w								
8			(8	H	X	h	x								
9)	9	I	Y	i	y								
A			*	:	J	Z	j	z								
B			+	;	K	[k	{								
C			,	<	L	\	l									
D			-	=	M]	m	}								
E			.	>	N	^	n	~								
F			/	?	O	_	o	⌘								

11.2 PRESENTATION

(1) PC-850, PC-857

	0	1	2	3	4	5	6	7	8	9	A	B	C	D	E	F
0				0	@	P	`	´				€				-
1			!	1	A	Q	À	Á								
2			"	2	B	R	Â	Ã								
3			#	3	C	S	Ä	Å								
4			\$	4	D	T	Ä	Å								
5			%	5	E	U	Ä	Å								
6			&	6	F	V	Ä	Å								
7			'	7	G	W	Ä	Å								
8			(8	H	X	Ä	Å								
9)	9	I	Y	Ä	Å								
A			.	:	J	Z	Ä	Å								
B			+	;	K	[Ä	Å								
C			,	<	L	\	Ä	Å								
D			-	=	M]	Ä	Å								
E			.	>	N	^	Ä	Å				¥				
F			/	?	O	_	Ä	Å								

(2) PC-8

The symbol “¥” is indicated by BEh for the PC-850 and by 9Dh for the PC-8. The symbol “-” is indicated by F0h for the PC-850 and this symbol does not exist for the PC-8.

(3) PC-852

The symbol “¥” is indicated by BEh for the PC-850 but this symbol does not exist for the PC-852.

(4) PC-851, PC-855, PC-1250, PC-1251, PC-1257, ARABIC

The symbol “¥” indicated by BEh and the symbol “-” indicated by F0h for the PC-850 does not exist for PC-851, PC-855, PC-1250, PC-1251, PC-1257 and ARABIC.

(5) PC-1252, PC-1254

The symbol “¥” indicated by BEh for the PC-850 is indicated by A5h for PC-1252 and PC-1254. The symbol “-” indicated by F0h for the PC-850 does not exist for PC-1252 and PC-1254. 88h indicates the symbol “^” and 98h indicates the symbol “~” for PC-1252 and PC-1254.

(6) PC-1253

The symbol “¥” indicated by BEh for the PC-850 is indicated by A5h for the PC-1253.

(7) LATIN9

The symbol “¥” indicated by BEh for the PC-850 is indicated by A5h for the LATIN9. A4h indicates the Euro font for the LATIN9.

11.3 OCR-A

(1) PC-850, PC-857

	0	1	2	3	4	5	6	7	8	9	A	B	C	D	E	F
0				0	@	P	ŕ	p								-
1			!	1	À	Q	a	q								
2			"	2	B	R	b	r								
3			#	3	C	S	c	s								
4			\$	4	D	T	d	t								
5			%	5	E	U	e	u								
6			&	6	F	V	f	v								
7			'	7	G	W	g	w								
8			(8	H	X	h	x								
9)	9	I	Y	i	y								
A			*	:	J	Z	j	z								
B			+	;	K	[k	{								
C			,	<	L	\	l									
D			-	=	M]	m	}								
E			.	>	N	^	n	␣				¥				
F			/	?	O	␣	o									

(2) PC-8

The symbol “¥” is indicated by BEh for the PC-850 and by 9Dh for the PC-8. The symbol “-” is indicated by F0h for the PC-850 and this symbol does not exist for the PC-8.

(3) PC-852

The symbol “¥” is indicated by BEh for the PC-850 but this symbol does not exist for the PC-852.

(4) PC-851, PC-855, PC-1250, PC-1251, PC-1257, LATIN9

The symbol “¥” indicated by BEh and the symbol “-” indicated by F0h for the PC-850 does not exist for PC-851, PC-855, PC-1250, PC-1251 PC-1257, and LATIN9.

(5) PC-1252, PC-1254

The symbol “¥” indicated by BEh for the PC-850 is indicated by A5h for PC-1252 and PC-1254. 88h indicates the symbol “^” and 98h indicates the symbol “~” for PC-1252 and PC-1254.

(6) PC-1253

The symbol “¥” indicated by BEh for the PC-850 is indicated by A5h for the PC-1253.

(7) LATIN9

The symbol “¥” indicated by BEh for the PC-850 is indicated by A5h for the LATIN9. The symbol “-” indicated by F0h for the PC-850 does not exist for the LATIN9.

11.4 OCR-B

(1) PC-850, PC-857

	0	1	2	3	4	5	6	7	8	9	A	B	C	D	E	F
0				0	@	P	`	p	o							-
1			!	1	A	Q	a	q	l							
2			"	2	B	R	b	r	2							
3			#	3	C	S	c	s	3							
4			\$	4	D	T	d	t	4							
5			%	5	E	U	e	u	5							
6			&	6	F	V	f	v	6							
7			'	7	G	W	g	w	7							
8			(8	H	X	h	x	8							
9)	9	I	Y	i	y	9							
A			+	:	J	Z	j	z								
B			+	;	K	[k	{								
C			,	<	L	\	l									
D			-	=	M]	m	}								
E			.	>	N	^	n	~				¥				
F			/	?	O	_	o	█								

The size of the numerals of codes 80h ~ 89h are reduced to 80%.

(2) PC-8

The symbol “¥” is indicated by BEh for the PC-850 and by 9Dh for the PC-8. The symbol “-” is indicated by F0h for the PC-850 but this symbol does not exist for the PC-8.

(3) PC-852

The symbol “¥” is indicated by BEh for the PC-850 and this symbol does not exist for the PC-852.

(4) PC-851, PC-855, PC-1250, PC-1251, PC-1257, ARABIC

The symbol “¥” indicated by BEh and the symbol “-” indicated by F0h for the PC-850 does not exist for PC-851, PC-855, PC-1250, PC-1251, PC-1257 and ARABIC.

(5) PC-1252, PC-1254, LATIN9

The symbol “¥” indicated by BEh for the PC-850 is indicated by A5h for PC-1252, PC-1254 and LATIN9.

The symbol “-” indicated by F0h for the PC-850 does not exist for PC-1252, PC-1254 and LATIN9. 98h indicates the symbol “~” for PC-1252, PC-1254 and LATIN9.

(6) PC-1253

The symbol “¥” indicated by BEh for the PC-850 is indicated by A5h for the PC-1253.

The symbol “-” indicated by F0h for the PC-850 does not exist for the PC-1253.

11.5 TEC OUTLINE FONT 1

In the case that “¥” is set for code 5CH

(1) All types of character code

	0	1	2	3	4	5	6	7	8	9	A	B	C	D	E	F
0				0	@	P	`	p								
1			!	1	A	Q	a	q								
2			”	2	B	R	b	r								
3			#	3	C	S	c	s								
4			\$	4	D	T	d	t								
5			%	5	E	U	e	u								
6			&	6	F	V	f	v								
7			'	7	G	W	g	w								
8			(8	H	X	h	x								
9)	9	I	Y	i	y								
A			*	:	J	Z	j	z								
B			+	;	K	[k	{								
C			,	<	L	¥										
D			-	=	M]	m	}								
E			.	>	N	^	n	~								
F			/	?	O	_	o	△								

* The shaded parts are Japanese.
They are omitted here.

In the case that “\” is set for code 5CH

(1) PC-850

	0	1	2	3	4	5	6	7	8	9	A	B	C	D	E	F
0				0	@	P	`	p	Ç	É	á	€				-
1			!	1	A	Q	a	q	ü	æ	í	€			ß	±
2			”	2	B	R	b	r	é	Æ	ó					
3			#	3	C	S	c	s	â	ô	ú					
4			\$	4	D	T	d	t	ä	ö	ñ				õ	
5			%	5	E	U	e	u	à	ò	Ñ					§
6			&	6	F	V	f	v	â	û	ª		ã		µ	÷
7			'	7	G	W	g	w	ç	ù	º					
8			(8	H	X	h	x	ê	ÿ	¿					°
9)	9	I	Y	i	y	ë	Ö						
A			*	:	J	Z	j	z	è	Ü	¬					•
B			+	;	K	[k	{	ï	ø	½					
C			,	<	L	\			î	£	¼					
D			-	=	M]	m	}	ì	Ø	¡	¢				²
E			.	>	N	^	n	~	Ä		«	¥				■
F			/	?	O	_	o	△	Å	f	»		¤			

(2) PC-8

	0	1	2	3	4	5	6	7	8	9	A	B	C	D	E	F
0				0	@	P	`	p	Ç	É	á	€			α	≡
1			!	1	A	Q	a	q	ü	æ	í	€			β	±
2			"	2	B	R	b	r	é	Æ	ó				Γ	≥
3			#	3	C	S	c	s	â	ô	ú				π	≤
4			\$	4	D	T	d	t	ä	ö	ñ				Σ	
5			%	5	E	U	e	u	à	ò	Ñ				σ	
6			&	6	F	V	f	v	å	û	°				μ	÷
7			'	7	G	W	g	w	ç	ù	°				τ	≈
8			(8	H	X	h	x	ê	ÿ	¿				Φ	°
9)	9	I	Y	i	y	ë	Ö	⌈				Θ	•
A			*	:	J	Z	j	z	è	Ü	⌋				Ω	•
B			+	;	K	[k	{	ï	ø	½				δ	√
C			,	<	L	\	l		î	£	¼				∞	n
D			-	=	M]	m	}	ì	¥	ì				∅	2
E			.	>	N	^	n	~	Ä	Pt	«				ε	■
F			/	?	O	_	o	△	Å	¡	»				∩	

(3) PC-852

	0	1	2	3	4	5	6	7	8	9	A	B	C	D	E	F
0				0	@	P	`	p	Ç	É	á	€				-
1			!	1	A	Q	a	q	ü		í	€			β	
2			"	2	B	R	b	r	é		ó					
3			#	3	C	S	c	s	â	ô	ú					
4			\$	4	D	T	d	t	ä	ö						
5			%	5	E	U	e	u								§
6			&	6	F	V	f	v								÷
7			'	7	G	W	g	w	ç							
8			(8	H	X	h	x								°
9)	9	I	Y	i	y	ë	Ö						
A			*	:	J	Z	j	z		Ü						•
B			+	;	K	[k	{								
C			,	<	L	\	l		î							
D			-	=	M]	m	}								
E			.	>	N	^	n	~	Ä		«					■
F			/	?	O	_	o	△			»		α			

(4) PC-857

	0	1	2	3	4	5	6	7	8	9	A	B	C	D	E	F
0				0	@	P	`	p	Ç	É	á	€		º		-
1			!	1	A	Q	a	q	ü	æ	í	€		ª	ß	±
2			"	2	B	R	b	r	é	Æ	ó					
3			#	3	C	S	c	s	â	ô	ú					
4			\$	4	D	T	d	t	ä	ö	ñ				õ	
5			%	5	E	U	e	u	à	ò	Ñ					§
6			&	6	F	V	f	v	å	û			ã		µ	÷
7			'	7	G	W	g	w	ç	ù						
8			(8	H	X	h	x	ê		¿					°
9)	9	I	Y	i	y	ë	Ö						
A			*	:	J	Z	j	z	è	Ü	¬					•
B			+	;	K	[k	{	ï	ø	½					
C			,	<	L	\	l		î	£	¼				ì	
D			-	=	M]	m	}		Ø	í	¢			ÿ	₂
E			.	>	N	^	n	~	Ä		«	¥				■
F			/	?	O	_	o	△	Å		»		¤			

(5) PC-851

	0	1	2	3	4	5	6	7	8	9	A	B	C	D	E	F
0				0	@	P	`	p	Ç			€				
1			!	1	A	Q	a	q	ü			€				±
2			"	2	B	R	b	r	é							
3			#	3	C	S	c	s	â	ô						
4			\$	4	D	T	d	t	ä	ö						
5			%	5	E	U	e	u	à							§
6			&	6	F	V	f	v		û						
7			'	7	G	W	g	w	ç	ù						
8			(8	H	X	h	x	ê							°
9)	9	I	Y	i	y	ë	Ö						
A			*	:	J	Z	j	z	è	Ü						
B			+	;	K	[k	{	ï		½					
C			,	<	L	\	l		î	£						
D			-	=	M]	m	}								
E			.	>	N	^	n	~	Ä		«					■
F			/	?	O	_	o	△			»					

(6) PC-855

	0	1	2	3	4	5	6	7	8	9	A	B	C	D	E	F
0				0	@	P	`	p				€				
1			!	1	A	Q	a	q				€				
2			"	2	B	R	b	r								
3			#	3	C	S	c	s								
4			\$	4	D	T	d	t								
5			%	5	E	U	e	u								
6			&	6	F	V	f	v								
7			'	7	G	W	g	w								
8			(8	H	X	h	x								
9)	9	I	Y	i	y								
A			*	:	J	Z	j	z								
B			+	;	K	[k	{								
C			,	<	L	\	l									
D			-	=	M]	m	}								§
E			.	>	N	^	n	~			«					■
F			/	?	O	_	o	△			»		α			

(7) PC-1250

	0	1	2	3	4	5	6	7	8	9	A	B	C	D	E	F
0				0	@	P	`	p				€				
1			!	1	A	Q	a	q				€			á	
2			"	2	B	R	b	r							â	
3			#	3	C	S	c	s								ó
4			\$	4	D	T	d	t			α		Ä		ä	ô
5			%	5	E	U	e	u				μ				
6			&	6	F	V	f	v						Ö		ö
7			'	7	G	W	g	w			§	·	Ç		ç	÷
8			(8	H	X	h	x								
9)	9	I	Y	i	y					É		é	
A			*	:	J	Z	j	z								ú
B			+	;	K	[k	{			«	»				ë
C			,	<	L	\	l				¬			Ü		ü
D			-	=	M]	m	}								í
E			.	>	N	^	n	~								î
F			/	?	O	_	o	△								ß

(8) PC-1251

	0	1	2	3	4	5	6	7	8	9	A	B	C	D	E	F
0				0	@	P	`	p				€				
1			!	1	A	Q	a	q				€				
2			"	2	B	R	b	r								
3			#	3	C	S	c	s								
4			\$	4	D	T	d	t			α					
5			%	5	E	U	e	u				μ				
6			&	6	F	V	f	v								
7			'	7	G	W	g	w			§	.				
8			(8	H	X	h	x								
9)	9	I	Y	i	y								
A			*	:	J	Z	j	z								
B			+	;	K	[k	{			«	»				
C			,	<	L	\	l				¬					
D			-	=	M]	m	}								
E			.	>	N	^	n	~								
F			/	?	O	_	o	△								

(9) PC-1252

	0	1	2	3	4	5	6	7	8	9	A	B	C	D	E	F
0				0	@	P	`	p				€			à	
1			!	1	A	Q	a	q			ı	€		Ñ	á	ñ
2			"	2	B	R	b	r			ç	²			â	ò
3			#	3	C	S	c	s	f		£				ã	ó
4			\$	4	D	T	d	t			α		Ä		ä	ô
5			%	5	E	U	e	u			¥	μ	Å		å	õ
6			&	6	F	V	f	v					Æ	Ö	æ	ö
7			'	7	G	W	g	w			§	.	Ç		ç	÷
8			(8	H	X	h	x	^	~				Ø	è	ø
9)	9	I	Y	i	y					É		é	ù
A			*	:	J	Z	j	z			a	o			ê	ú
B			+	;	K	[k	{			«	»			ë	û
C			,	<	L	\	l				¬	¼		Ü	ì	ü
D			-	=	M]	m	}				½			í	
E			.	>	N	^	n	~							î	
F			/	?	O	_	o	△				¿		ß	ï	ÿ

(10) PC-1253

	0	1	2	3	4	5	6	7	8	9	A	B	C	D	E	F
0				0	@	P	`	p				€				
1			!	1	A	Q	a	q				€				
2			"	2	B	R	b	r				²				
3			#	3	C	S	c	s	<i>f</i>		£					
4			\$	4	D	T	d	t			α					
5			%	5	E	U	e	u			¥	μ				
6			&	6	F	V	f	v								
7			'	7	G	W	g	w			§	.				
8			(8	H	X	h	x								
9)	9	I	Y	i	y								
A			*	:	J	Z	j	z			a					
B			+	;	K	[k	{			«	»				
C			,	<	L	\	l				¬					
D			-	=	M]	m	}				½				
E			.	>	N	^	n	~								
F			/	?	O	_	o	△								

(11) PC-1254

	0	1	2	3	4	5	6	7	8	9	A	B	C	D	E	F
0				0	@	P	`	p				€			à	
1			!	1	A	Q	a	q			ı	€		Ñ	á	ñ
2			"	2	B	R	b	r			ç	²			â	ò
3			#	3	C	S	c	s	<i>f</i>		£				ã	ó
4			\$	4	D	T	d	t			α		Ä		ä	ô
5			%	5	E	U	e	u			¥	μ	Å		å	õ
6			&	6	F	V	f	v					Æ	Ö	æ	ö
7			'	7	G	W	g	w			§	.	Ç		ç	÷
8			(8	H	X	h	x	^	~				Ø	è	ø
9)	9	I	Y	i	y					É		é	ù
A			*	:	J	Z	j	z			a	o			ê	ú
B			+	;	K	[k	{			«	»			ë	û
C			,	<	L	\	l				¬	¼		Ü	ì	ü
D			-	=	M]	m	}				½			í	
E			.	>	N	^	n	~							î	
F			/	?	O	_	o	△				¿		ß	ï	ÿ

(12) PC-1257

	0	1	2	3	4	5	6	7	8	9	A	B	C	D	E	F
0				0	@	P	`	p				€				
1			!	1	A	Q	a	q				€				
2			"	2	B	R	b	r			¢	²				
3			#	3	C	S	c	s			£					ó
4			\$	4	D	T	d	t			¤		Ä		ä	
5			%	5	E	U	e	u				μ	Å		å	õ
6			&	6	F	V	f	v						Ö		ö
7			'	7	G	W	g	w			§	.				÷
8			(8	H	X	h	x			Ø	ø				
9)	9	I	Y	i	y					É		é	
A			*	:	J	Z	j	z								
B			+	;	K	[k	{			«	»				
C			,	<	L	\	l				¬	¼		Ü		ü
D			-	=	M]	m	}				½				
E			.	>	N	^	n	~								
F			/	?	O	_	o	△			Æ	æ		ß		

(13) LATIN9

	0	1	2	3	4	5	6	7	8	9	A	B	C	D	E	F
0				0	@	P	`	p				€			à	
1			!	1	A	Q	a	q			ı	€		Ñ	á	ñ
2			"	2	B	R	b	r			¢	²			â	ò
3			#	3	C	S	c	s			£				ã	ó
4			\$	4	D	T	d	t			€		Ä		ä	ô
5			%	5	E	U	e	u			¥	μ	Å		å	õ
6			&	6	F	V	f	v					Æ	Ö	æ	ö
7			'	7	G	W	g	w			§	.	Ç		ç	÷
8			(8	H	X	h	x						Ø	è	ø
9)	9	I	Y	i	y					É		é	ù
A			*	:	J	Z	j	z			a	o			ê	ú
B			+	;	K	[k	{			«	»			ë	û
C			,	<	L	\	l				¬			Ü	ì	ü
D			-	=	M]	m	}							í	
E			.	>	N	^	n	~							î	
F			/	?	O	_	o	△				ı		ß	ï	ÿ

(14) ARABIC

	0	1	2	3	4	5	6	7	8	9	A	B	C	D	E	F
0				0	@	P	`	p				€				
1			!	1	A	Q	a	q				€				
2			"	2	B	R	b	r								
3			#	3	C	S	c	s								
4			\$	4	D	T	d	t								
5			%	5	E	U	e	u								
6			&	6	F	V	f	v								
7			'	7	G	W	g	w								
8			(8	H	X	h	x								
9)	9	I	Y	i	y								
A			*	:	J	Z	j	z								
B			+	;	K	[k	{								
C			,	<	L	\	l									
D			-	=	M]	m	}								
E			.	>	N	^	n	~								
F			/	?	O	_	o	△								

11.6 PRICE FONT

(1) All types of character code

	0	1	2	3	4	5	6	7	8	9	A	B	C	D	E	F
0				0	円											
1				1												
2				2												
3				3												
4			\$	4												
5			%	5												
6				6												
7				7												
8				8												
9				9												
A																
B																
C			,			¥										
D			-													
E			.					~								
F			/													

11.7 TEC OUTLINE FONT 2, 3

(1) PC-850

	0	1	2	3	4	5	6	7	8	9	A	B	C	D	E	F
0			0	@	P	`	p	Ç	É	á	€			ð	Ó	-
1		!	1	A	Q	a	q	ü	æ	í				Ð	ß	±
2		"	2	B	R	b	r	é	Æ	ó				Ê	Ô	=
3		#	3	C	S	c	s	â	ô	ú				Ë	Ò	¾
4		\$	4	D	T	d	t	ä	ö	ñ				È	õ	¶
5		%	5	E	U	e	u	à	ò	Ñ	Á			1	Õ	§
6		&	6	F	V	f	v	â	û	ª	Â	ã	í	µ	÷	
7		'	7	G	W	g	w	ç	ù	º	À	Ã	î	þ	¸	
8		(8	H	X	h	x	ê	ÿ	¿	©			ï	þ	°
9)	9	I	Y	i	y	ë	Ö	®				Ú	¨	
A		*	:	J	Z	j	z	è	Ü	¬				Û	•	
B		+	;	K	[k	{	ï	ø	½				Ù	¹	
C		,	<	L	\	l		î	£	¼				ý	³	
D		-	=	M]	m	}	ì	Ø	¡	¢			ÿ	²	
E		.	>	N	^	n	~	Ä	x	«	¥			ì	´	■
F		/	?	O	_	o		Å	f	»		¤		'		

(2) PC-8

	0	1	2	3	4	5	6	7	8	9	A	B	C	D	E	F
0			0	@	P	`	p	Ç	É	á	€					
1		!	1	A	Q	a	q	ü	æ	í						±
2		"	2	B	R	b	r	é	Æ	ó						
3		#	3	C	S	c	s	â	ô	ú						
4		\$	4	D	T	d	t	ä	ö	ñ						
5		%	5	E	U	e	u	à	ò	Ñ						
6		&	6	F	V	f	v	â	û	ª				µ	÷	
7		'	7	G	W	g	w	ç	ù	º						
8		(8	H	X	h	x	ê	ÿ	¿						°
9)	9	I	Y	i	y	ë	Ö							
A		*	:	J	Z	j	z	è	Ü	¬						•
B		+	;	K	[k	{	ï	ø	½						
C		,	<	L	\	l		î	£	¼						
D		-	=	M]	m	}	ì	¥	¡						²
E		.	>	N	^	n	~	Ä		«						■
F		/	?	O	_	o		Å	f	»						

(3) PC-852

	0	1	2	3	4	5	6	7	8	9	A	B	C	D	E	F
0			0	@	P	`	p	Ç	É	á	€		đ	Ó	-	
1		!	1	A	Q	a	q	ü	Í	í			Đ	ß	~	
2		"	2	B	R	b	r	é	Í	ó			Đ	Ô	˘	
3		#	3	C	S	c	s	â	ô	ú			Ë	Ñ	˘	
4		\$	4	D	T	d	t	ä	ö	À			đ	ñ	˘	
5		%	5	E	U	e	u	ü	Ĺ	ą	Á		Ń	ñ	§	
6		&	6	F	V	f	v	ć	ĩ	Ž	Â	Ă	í	Š	÷	
7		'	7	G	W	g	w	ç	Ś	ż	Ě	ă	î	š	˘	
8		(8	H	X	h	x	ı	ś	Ę	Ş		ě	Ŕ	˚	
9)	9	I	Y	i	y	ë	Ö	ę				Ú	˘	
A		*	:	J	Z	j	z	Ő	Ü	ı				ı	•	
B		+	;	K	[k	{	ő	Ť	ż				Ú	ű	
C		,	<	L	\	l		î	ť	Č				ý	Ř	
D		-	=	M]	m	}	ž	ł	ş	Ž		ı	Ý	ř	
E		.	>	N	^	n	~	Ä	x	«	ž		Ú	t	■	
F		/	?	O	_	o		Ć	č	»		α				

(4) PC-857

	0	1	2	3	4	5	6	7	8	9	A	B	C	D	E	F
0			0	@	P	`	p	Ç	É	á	€		º	Ó	-	
1		!	1	A	Q	a	q	ü	æ	í			ª	ß	±	
2		"	2	B	R	b	r	é	Æ	ó			Ê	Ô		
3		#	3	C	S	c	s	â	ô	ú			Ë	Ò	¼	
4		\$	4	D	T	d	t	ä	ö	ñ			È	õ	¶	
5		%	5	E	U	e	u	à	ò	Ñ	Á			Õ	§	
6		&	6	F	V	f	v	â	û	Ğ	Â	ă	í	µ	÷	
7		'	7	G	W	g	w	ç	ù	ğ	À	Ă	î		˘	
8		(8	H	X	h	x	ê	ı	ı	©		ï	x	˚	
9)	9	I	Y	i	y	ë	Ö	®				Ú	˘	
A		*	:	J	Z	j	z	è	Ü	ı				Û	•	
B		+	;	K	[k	{	ï	ø	½				Ù	1	
C		,	<	L	\	l		î	£	¼				ı	3	
D		-	=	M]	m	}	ı	Ø	ı	¢		ı	ÿ	2	
E		.	>	N	^	n	~	Ä	Ş	«	¥		ı		■	
F		/	?	O	_	o		Å	ş	»		α				

(5) PC-851

	0	1	2	3	4	5	6	7	8	9	A	B	C	D	E	F
0			0	@	P	`	p	Ç			€					
1		!	1	A	Q	a	q	ü								±
2		”	2	B	R	b	r	é								
3		#	3	C	S	c	s	â	ô							
4		\$	4	D	T	d	t	ä	ö							
5		%	5	E	U	e	u	à								§
6		&	6	F	V	f	v		û							
7		'	7	G	W	g	w	ç	ù							°
8		(8	H	X	h	x	ê								°
9)	9	I	Y	i	y	ë	Ö							”
A		*	:	J	Z	j	z	è	Ü							
B		+	;	K	[k	{	ï		½						
C		,	<	L	\	l		î	£							
D		-	=	M]	m	}									
E		.	>	N	^	n	~	Ä		«						■
F		/	?	O	_	o				»						

(6) PC-855

	0	1	2	3	4	5	6	7	8	9	A	B	C	D	E	F
0			0	@	P	`	p				€					
1		!	1	A	Q	a	q									
2		”	2	B	R	b	r									
3		#	3	C	S	c	s									
4		\$	4	D	T	d	t									
5		%	5	E	U	e	u									
6		&	6	F	V	f	v									
7		'	7	G	W	g	w									
8		(8	H	X	h	x									
9)	9	I	Y	i	y									
A		*	:	J	Z	j	z									
B		+	;	K	[k	{									
C		,	<	L	\	l										
D		-	=	M]	m	}									§
E		.	>	N	^	n	~			«						■
F		/	?	O	_	o				»		¤				

(7) PC-1250

	0	1	2	3	4	5	6	7	8	9	A	B	C	D	E	F
0			0	@	P	`	p				€	Ř	Đ	ř	đ	
1		!	1	A	Q	a	q			˘	±	Á	Ñ	á	ñ	
2		”	2	B	R	b	r			˘	,		Ň	â	ň	
3		#	3	C	S	c	s			Ł	ł		Ó		ó	
4		\$	4	D	T	d	t			Ɑ	´	Ä	Ö	ä	ö	
5		%	5	E	U	e	u			Α	μ	Í	Õ	í	õ	
6		&	6	F	V	f	v			ı	¶	Č	Ö	č	ö	
7		'	7	G	W	g	w			§	·	Ç	x	ç	÷	
8		(8	H	X	h	x			”	,	Č	Ř	č	ř	
9)	9	I	Y	i	y				a	É	Ú	é	ú	
A		*	:	J	Z	j	z	Š	š	Ş	ş	Ě	Ú	ě	ú	
B		+	;	K	[k	{			«	»	Ě	Ů	ě	ů	
C		,	<	L	\	l		Ś	ś	¬	Ł	Ě	Ü	ě	ü	
D		-	=	M]	m	}	Ť	ť	-	”	Í	Ý	í	ý	
E		.	>	N	^	n	~	Ž	ž	®	Ĺ	Î	Ĵ	î	ĵ	
F		/	?	O	_	o		Ž	ž	Ž	ž	Ď	ß	ď		

(8) PC-1251

	0	1	2	3	4	5	6	7	8	9	A	B	C	D	E	F
0			0	@	P	`	p				€					
1		!	1	A	Q	a	q				±					
2		”	2	B	R	b	r									
3		#	3	C	S	c	s									
4		\$	4	D	T	d	t			Ɑ						
5		%	5	E	U	e	u				μ					
6		&	6	F	V	f	v			ı	¶					
7		'	7	G	W	g	w			§	·					
8		(8	H	X	h	x									
9)	9	I	Y	i	y									
A		*	:	J	Z	j	z									
B		+	;	K	[k	{			«	»					
C		,	<	L	\	l				¬						
D		-	=	M]	m	}			-						
E		.	>	N	^	n	~			®						
F		/	?	O	_	o										

(9) PC-1252

	0	1	2	3	4	5	6	7	8	9	A	B	C	D	E	F
0			0	@	P	`	p				€		Đ	à	đ	
1		!	1	A	Q	a	q				ı	±	Á	Ñ	á	ñ
2		"	2	B	R	b	r				²		Ò	â	ò	
3		#	3	C	S	c	s	<i>f</i>		£	³		Ó		ó	
4		\$	4	D	T	d	t			¤	'	Ä	Ö	ä	ö	
5		%	5	E	U	e	u				µ	Å	Õ	å	õ	
6		&	6	F	V	f	v			ı	¶	Æ	Ö	æ	ö	
7		'	7	G	W	g	w			§		Ç	x	ç	÷	
8		(8	H	X	h	x	^	~	¨	,	È	Ø	è	ø	
9)	9	I	Y	i	y				¹	É	Ù	é	ù	
A		*	:	J	Z	j	z	Š	š	ª	º	Ê	Ú	ê	ú	
B		+	;	K	[k	{			«	»	Ë	Û	ë	û	
C		,	<	L	\	l				¬	¼	Ì	Ü	ì	ü	
D		-	=	M]	m	}			-	½	Í	Ý	í	ý	
E		.	>	N	^	n	~	Ž	ž	®		Î		î		
F		/	?	O	_	o					¿	İ	ß	ï	ÿ	

(10) PC-1253

	0	1	2	3	4	5	6	7	8	9	A	B	C	D	E	F
0			0	@	P	`	p				€					
1		!	1	A	Q	a	q					±				
2		"	2	B	R	b	r					²				
3		#	3	C	S	c	s	<i>f</i>		£	³					
4		\$	4	D	T	d	t			¤						
5		%	5	E	U	e	u				µ					
6		&	6	F	V	f	v			ı	¶					
7		'	7	G	W	g	w			§	.					
8		(8	H	X	h	x			¨						
9)	9	I	Y	i	y									
A		*	:	J	Z	j	z			ª						
B		+	;	K	[k	{			«	»					
C		,	<	L	\	l				¬						
D		-	=	M]	m	}			-	½					
E		.	>	N	^	n	~			®						
F		/	?	O	_	o										

(11) PC-1254

	0	1	2	3	4	5	6	7	8	9	A	B	C	D	E	F
0			0	@	P	`	p				€			à		
1		!	1	A	Q	a	q				ı	±	Á	Ñ	á	ñ
2		"	2	B	R	b	r					²	Ò	â	ò	
3		#	3	C	S	c	s	f		£	³		Ó		ó	
4		\$	4	D	T	d	t			¤	'	Ä	Ö	ä	ö	
5		%	5	E	U	e	u				μ	Å	Õ	å	õ	
6		&	6	F	V	f	v			ı	¶	Æ	Ö	æ	ö	
7		'	7	G	W	g	w			§	·	Ç	x	ç	÷	
8		(8	H	X	h	x	^	~	¨	,	È	Ø	è	ø	
9)	9	I	Y	i	y				¹	É	Ù	é	ù	
A		*	:	J	Z	j	z	Š	š	a	º	Ê	Ú	ê	ú	
B		+	;	K	[k	{			«	»	Ë	Û	ë	û	
C		,	<	L	\	l				¬	¼	Ì	Ü	ì	ü	
D		-	=	M]	m	}			-	½	Í		í	¹	
E		.	>	N	^	n	~			®		Î	Ş	î	ş	
F		/	?	O	_	o				-	¿	Ï	ß	ï	ÿ	

(12) PC-1257

	0	1	2	3	4	5	6	7	8	9	A	B	C	D	E	F
0			0	@	P	`	p				€	À	Š	ą	š	
1		!	1	A	Q	a	q					±		Ñ		ń
2		"	2	B	R	b	r					²				
3		#	3	C	S	c	s			£	³	Ć	Ó	ć	ó	
4		\$	4	D	T	d	t			¤	'	Ä		ä		
5		%	5	E	U	e	u				μ	Å	Õ	å	õ	
6		&	6	F	V	f	v			ı	¶	Æ	Ö	æ	ö	
7		'	7	G	W	g	w			§	·		x		÷	
8		(8	H	X	h	x			Ø	ø	Č		č		
9)	9	I	Y	i	y				¹	É	Ł	é	ł	
A		*	:	J	Z	j	z					Ž	Ś	ž	ś	
B		+	;	K	[k	{			«	»					
C		,	<	L	\	l				¬	¼		Ü		ü	
D		-	=	M]	m	}		¨	-	½		Ž		ž	
E		.	>	N	^	n	~		¨	®			Ž		ž	
F		/	?	O	_	o				Æ	æ		ß			

(13) LATIN9

	0	1	2	3	4	5	6	7	8	9	A	B	C	D	E	F
0			0	@	P	`	p				€		Đ	à	ñ	
1		!	1	A	Q	a	q				ı	±	Á	Ñ	á	ò
2		”	2	B	R	b	r				²		Ò	â	ó	
3		#	3	C	S	c	s				£	³		Ó		ô
4		\$	4	D	T	d	t				ö	Ž	Ä	Ö	ä	õ
5		%	5	E	U	e	u				μ	Å	Õ	å	ö	
6		&	6	F	V	f	v				Š	¾	Æ	Ö	æ	÷
7		'	7	G	W	g	w				§		Ç	x	ç	ø
8		(8	H	X	h	x				š	ž	È	Ø	è	ù
9)	9	I	Y	i	y				¹		É	Ù	é	ú
A		*	:	J	Z	j	z				ª	º	Ê	Ú	ê	û
B		+	;	K	[k	{				«	»	Ë	Û	ë	ü
C		,	<	L	\	l					¬		Ì	Ü	ì	ý
D		-	=	M]	m	}				-		Í	Ý	í	
E		.	>	N	^	n	~				®		Î		î	ÿ
F		/	?	O	_	o						¿	İ	ß	ï	

(14) ARABIC

	0	1	2	3	4	5	6	7	8	9	A	B	C	D	E	F
0			0	@	P	`	p				€					
1		!	1	A	Q	a	q									
2		”	2	B	R	b	r									
3		#	3	C	S	c	s									
4		\$	4	D	T	d	t									
5		%	5	E	U	e	u									
6		&	6	F	V	f	v									
7		'	7	G	W	g	w									
8		(8	H	X	h	x									
9)	9	I	Y	i	y									
A		*	:	J	Z	j	z									
B		+	;	K	[k	{									
C		,	<	L	\	l										
D		-	=	M]	m	}									
E		.	>	N	^	n	~									
F		/	?	O	_	o										

11.8 TrueType FONT

(1) PC-850

	2	3	4	5	6	7	8	9	A	B	C	D	E	F
0	0	@	P	`	p	Ç	É	á	⋮	⊥	ð	Ó	-	
1	!	1	A	Q	a	q	ü	æ	í	⊗	⊥	Ð	β	±
2	"	2	B	R	b	r	é	Æ	ó	⊗	⊥	Ê	Ô	=
3	#	3	C	S	c	s	â	ô	ú		⊥	Ë	Ò	¾
4	\$	4	D	T	d	t	ä	ö	ñ	⊥	—	È	õ	¶
5	%	5	E	U	e	u	à	ò	Ñ	Á	+	ı	Õ	§
6	&	6	F	V	f	v	â	û	ª	Â	ã	Í	μ	÷
7	'	7	G	W	g	w	ç	ù	º	À	Ã	Î	þ	,
8	(8	H	X	h	x	ê	ÿ	¿	©	⊥	İ	þ	°
9)	9	I	Y	i	y	ë	Ö	®	⊥	⊥	⊥	Ú	·
A	*	:	J	Z	j	z	è	Û	¬		⊥	⊥	Û	·
B	+	;	K	[k	{	ï	ø	½	⊥	⊥	■	Ù	¹
C	,	<	L	\	l		î	£	¼	⊥	⊥	■	ý	³
D	-	=	M]	m	}	ì	Ø	ı	⊥	⊥	⊥	Ý	²
E	.	>	N	^	n	~	Ä	×	«	¥	⊥	⊥	ı	▪
F	/	?	O	_	o	△	Å	f	»	⊥	⊥	■	'	

(2) PC-8

	2	3	4	5	6	7	8	9	A	B	C	D	E	F
0	0	@	P	`	p	Ç	É	á	⋮	⊥	⊥	α	≡	
1	!	1	A	Q	a	q	ü	æ	í	⊗	⊥	⊥	β	±
2	"	2	B	R	b	r	é	Æ	ó	⊗	⊥	⊥	Γ	≥
3	#	3	C	S	c	s	â	ô	ú		⊥	⊥	π	≤
4	\$	4	D	T	d	t	ä	ö	ñ	⊥	—	⊥	Σ	∫
5	%	5	E	U	e	u	à	ò	Ñ	⊥	+	⊥	σ	∫
6	&	6	F	V	f	v	â	û	ª	⊥	⊥	⊥	μ	÷
7	'	7	G	W	g	w	ç	ù	º	⊥	⊥	⊥	τ	≈
8	(8	H	X	h	x	ê	ÿ	¿	⊥	⊥	⊥	Φ	°
9)	9	I	Y	i	y	ë	Ö	⊥	⊥	⊥	⊥	Θ	·
A	*	:	J	Z	j	z	è	Û	¬		⊥	⊥	Ω	·
B	+	;	K	[k	{	ï	ı	½	⊥	⊥	■	δ	√
C	,	<	L	\	l		î	£	¼	⊥	⊥	■	∞	n
D	-	=	M]	m	}	ì	¥	ı	⊥	⊥	■	φ	²
E	.	>	N	^	n	~	Ä	Pt	«	⊥	⊥	⊥	ε	▪
F	/	?	O	_	o	△	Å	f	»	⊥	⊥	■	∩	

(3) PC-852

	2	3	4	5	6	7	8	9	A	B	C	D	E	F
0	0	@	P	`	p	Ç	É	á	⋮	↳	đ	Ó	-	
1	!	1	A	Q	a	q	ü	Í	í	⊞	±	Đ	β	˘
2	"	2	B	R	b	r	é	í	ó	⊞	±	Đ	Ó	.
3	#	3	C	S	c	s	â	ô	ú		↳	Ë	Ñ	˘
4	\$	4	D	T	d	t	ä	ö	À	↳	—	đ	ñ	˘
5	%	5	E	U	e	u	ù	L	á	+	Ñ	ñ	§	
6	&	6	F	V	f	v	é	í	Ž	À	Ã	Í	Š	÷
7	'	7	G	W	g	w	ç	Š	ž	Ë	ã	Í	š	,
8	(8	H	X	h	x	ı	š	Ë	Ş	↳	ě	Ř	°
9)	9	I	Y	i	y	ë	Ö	ę	↳	↳	↳	Ú	˘
A	*	:	J	Z	j	z	Ó	Ü			↳	↳	ı	˘
B	+	;	K	[k	{	ó	Ť	ž	↳	↳	↳	Ů	ú
C	,	<	L	\	l		ı	č	↳	↳	↳	↳	ý	Ř
D	-	=	M]	m	}	Ž	Ł	ş	Ž	=	↳	Ý	ř
E	.	>	N	^	n	˘	Ä	×	«	ž	↳	↳	ı	▪
F	/	?	O	_	o	△	Ć	č	»	↳	↳	↳	ı	

(4) PC-857

	2	3	4	5	6	7	8	9	A	B	C	D	E	F
0	0	@	P	`	p	Ç	É	á	⋮	↳	°	Ó	-	
1	!	1	A	Q	a	q	ü	æ	í	⊞	±	ª	β	±
2	"	2	B	R	b	r	é	Æ	ó	⊞	±	Ê	Ô	
3	#	3	C	S	c	s	â	ô	ú		↳	Ë	Ò	¼
4	\$	4	D	T	d	t	ä	ö	ñ	↳	—	È	ø	¶
5	%	5	E	U	e	u	à	ò	Ñ	Á	+	↳	Õ	§
6	&	6	F	V	f	v	á	ú	Ğ	À	Ã	Í	μ	÷
7	'	7	G	W	g	w	ç	ù	ğ	À	Ã	Í		,
8	(8	H	X	h	x	é	ı	ı	©	↳	↳	ı	°
9)	9	I	Y	i	y	ë	Ö	®	↳	↳	↳	Ú	˘
A	*	:	J	Z	j	z	è	Ü	↳		↳	↳	↳	˘
B	+	;	K	[k	{	ı	ø	½	↳	↳	↳	↳	ı ¹
C	,	<	L	\	l		ı	£	¼	↳	↳	↳	↳	ı ³
D	-	=	M]	m	}	ı	Ø	ı	ç	=	↳	ı	ı ²
E	.	>	N	^	n	˘	Ä	Ş	«	↳	↳	↳	↳	ı
F	/	?	O	_	o	△	Å	ş	»	↳	↳	↳	ı	

(5) PC-851

	2	3	4	5	6	7	8	9	A	B	C	D	E	F
0	0	@	P	`	p	Ç	ı	ï	⋮	⊥	Т	ζ	-	
1	!	1	A	Q	a	q	ü	ı	⊞	⊥	Y	η	±	
2	"	2	B	R	b	r	é	Ó	ó	⊞	⊥	Φ	θ	υ
3	#	3	C	S	c	s	â	ô	ú		⊥	X	ι	φ
4	\$	4	D	T	d	t	ä	ö	Ä	⊥	—	Ψ	κ	χ
5	%	5	E	U	e	u	à	Y	B	K	+	Ω	λ	§
6	&	6	F	V	f	v	À	ù	Γ	Λ	Π	α	μ	ψ
7	'	7	G	W	g	w	ç	ù	Δ	M	P	β	ν	,
8	(8	H	X	h	x	ê	Ω	E	N	⊥	γ	ξ	°
9)	9	I	Y	i	y	ë	Ö	Z	⊥	⊥	⊥	o	¨
A	*	:	J	Z	j	z	è	Ü	H		⊥	⊥	π	ω
B	+	;	K	[k	{	ï	á	½	⊥	⊥	■	ρ	ü
C	,	<	L	\	l		î	£	Θ	⊥	⊥	■	σ	Û
D	-	=	M]	m	}	É	é	I	Ξ	=	δ	ς	ώ
E	.	>	N	^	n	~	Ä	ñ	<	O	⊥	ε	τ	▪
F	/	?	O	_	o	△	‘	H	í	»	⊥	Σ	■	'

(6) PC-855

	2	3	4	5	6	7	8	9	A	B	C	D	E	F
0	0	@	P	`	p	ђ	љ	а	⋮	⊥	л	Я	-	
1	!	1	A	Q	a	q	Ђ	Љ	А	⊞	⊥	Л	р	ы
2	"	2	B	R	b	r	ѓ	њ	б	⊞	⊥	М	Р	Ы
3	#	3	C	S	c	s	Ѓ	Њ	Б		⊥	М	с	з
4	\$	4	D	T	d	t	ѐ	ћ	ц	⊥	—	н	С	З
5	%	5	E	U	e	u	Ě	ћ	Ц	x	+	Н	т	ш
6	&	6	F	V	f	v	є	ќ	д	X	к	о	Т	Ш
7	'	7	G	W	g	w	Є	Ќ	Д	и	К	О	у	э
8	(8	H	X	h	x	s	ŷ	e	И	⊥	п	У	Э
9)	9	I	Y	i	y	S	Ÿ	E	⊥	⊥	⊥	ж	ш
A	*	:	J	Z	j	z	i	ц	ф		⊥	⊥	Ж	Ш
B	+	;	K	[k	{	l	ц	Ф	⊥	⊥	■	в	ч
C	,	<	L	\	l		ï	ю	г	⊥	⊥	■	В	Ч
D	-	=	M]	m	}	İ	Ю	Г	й	=	П	ь	§
E	.	>	N	^	n	~	j	ь	«	Й	⊥	я	Ь	▪
F	/	?	O	_	o	△	J	Ђ	»	⊥	□	■	№	

(7) PC-1250

	2	3	4	5	6	7	8	9	A	B	C	D	E	F
0		0	@	P	`	p	€		°	Ř	Đ	ř	đ	
1	!	1	A	Q	a	q		‘	˘	±	Á	Ň	á	ň
2	"	2	B	R	b	r	,	’	˘	˘	Â	Ň	â	ň
3	#	3	C	S	c	s		“	Ł	ł	Ă	Ó	ă	ó
4	\$	4	D	T	d	t	„	”	□	´	Ä	Ô	ä	ô
5	%	5	E	U	e	u	...	•	Α	μ	Í	Ó	í	ó
6	&	6	F	V	f	v	†	-		¶	Ć	Ö	ć	ö
7	'	7	G	W	g	w	‡	—	§	·	Ç	×	ç	÷
8	(8	H	X	h	x			˙	˙	Č	Ř	č	ř
9)	9	I	Y	i	y	‰	™	©	ą	É	Ú	é	ú
A	*	:	J	Z	j	z	Š	š	Ş	ş	Ę	Ú	ę	ú
B	+	;	K	[k	{	<	>	«	»	Ë	Ů	ë	ů
C	,	<	L	\	l		Ś	ś	¬	Ł	Ě	Ü	ě	ü
D	-	=	M]	m	}	Ť	ť	-	˘	Í	Ý	í	ý
E	.	>	N	^	n	~	Ž	ž	®	Ŧ	İ	ı	ı	ı
F	/	?	O	_	o	☒	Ž	ž	Ž	ž	Đ	β	đ	·

(8) PC-1251

	2	3	4	5	6	7	8	9	A	B	C	D	E	F
0		0	@	P	`	p	Ђ	ђ	°	А	Р	а	р	
1	!	1	A	Q	a	q	Ѓ	ѓ	˘	Ў	±	Б	С	б
2	"	2	B	R	b	r	,	’	˘	І	В	Т	в	т
3	#	3	C	S	c	s	Ѕ	ѕ	“	Ј	И	Г	У	г
4	\$	4	D	T	d	t	„	”	□	Г	Д	Ф	д	ф
5	%	5	E	U	e	u	...	•	Г	μ	Е	Х	е	х
6	&	6	F	V	f	v	†	-		¶	Ж	Ц	ж	ц
7	'	7	G	W	g	w	‡	—	§	·	З	Ч	з	ч
8	(8	H	X	h	x	€		Ё	ё	И	Ш	и	ш
9)	9	I	Y	i	y	‰	™	©	№	Й	Щ	й	щ
A	*	:	J	Z	j	z	Љ	љ	Є	с	К	Ъ	к	ъ
B	+	;	K	[k	{	<	>	«	»	Л	Ы	л	ы
C	,	<	L	\	l		Њ	њ	¬	Ј	М	Ь	м	ь
D	-	=	M]	m	}	Ќ	ќ	-	Ѕ	Н	Э	н	э
E	.	>	N	^	n	~	Ў	ў	®	ѕ	О	Ю	о	ю
F	/	?	O	_	o	☒	Ц	ц	Ѓ	ѓ	П	Я	п	я

(9) PC-1252

	2	3	4	5	6	7	8	9	A	B	C	D	E	F
0		0	@	P	`	p	€		°	À	Ð	à	ð	
1	!	1	A	Q	a	q		'	ı	±	Á	Ñ	á	ñ
2	"	2	B	R	b	r	,	'	ç	²	Â	Ò	â	ò
3	#	3	C	S	c	s	f	"	£	³	Ã	Ó	ã	ó
4	\$	4	D	T	d	t	„	”	¤	´	Ä	Ô	ä	ô
5	%	5	E	U	e	u	...	•	¥	µ	Å	Õ	å	õ
6	&	6	F	V	f	v	†	-		¶	Æ	Ö	æ	ö
7	'	7	G	W	g	w	‡	—	§	·	Ç	×	ç	÷
8	(8	H	X	h	x	^	~	¨	,	È	Ø	è	ø
9)	9	I	Y	i	y	‰	™	©	ı	É	Ù	é	ù
A	*	:	J	Z	j	z	Š	š	ª	º	Ê	Ú	ê	ú
B	+	;	K	[k	{	<	>	«	»	Ë	Û	ë	û
C	,	<	L	\	l		Œ	œ	¬	¼	Ì	Ü	ì	ü
D	-	=	M]	m	}			-	½	Í	Ý	í	ý
E	.	>	N	^	n	~	Ž	ž	®	¾	Î	Þ	î	þ
F	/	?	O	_	o	☒			ÿ	ˉ	İ	β	ı	ÿ

(10) PC-1253

	2	3	4	5	6	7	8	9	A	B	C	D	E	F	
0		0	@	P	`	p	€		°	ı	Π	ϖ	π		
1	!	1	A	Q	a	q		'	¨	±	A	P	α	ρ	
2	"	2	B	R	b	r	,	'	²	B		β	ç		
3	#	3	C	S	c	s	f	"	£	³	Γ	Σ	γ	σ	
4	\$	4	D	T	d	t	„	”	¤	´	Δ	T	δ	τ	
5	%	5	E	U	e	u	...	•	¥	µ	E	Υ	ε	υ	
6	&	6	F	V	f	v	†	-		¶	Z	Φ	ζ	φ	
7	'	7	G	W	g	w	‡	—	§	·	H	X	η	χ	
8	(8	H	X	h	x			¨	´	E	Θ	Ψ	θ	ψ
9)	9	I	Y	i	y	‰	™	©	´	H	I	Ω	ι	ω
A	*	:	J	Z	j	z			ª	´	I	K	İ	κ	ı
B	+	;	K	[k	{	<	>	«	»	Λ	ÿ	λ	ϖ	
C	,	<	L	\	l				¬	´	O	M	ά	μ	ό
D	-	=	M]	m	}			-	½	N	έ	ν	ύ	
E	.	>	N	^	n	~			®	´	Υ	Ξ	ή	ξ	ώ
F	/	?	O	_	o	☒			—	Ω	O	ί	ο		

(11) PC-1254

	2	3	4	5	6	7	8	9	A	B	C	D	E	F
0		0	@	P	`	p	€		°	À	Ğ	à	ğ	
1	!	1	A	Q	a	q		‘	±	Á	Ñ	á	ñ	
2	"	2	B	R	b	r	,	’	²	Â	Ò	â	ò	
3	#	3	C	S	c	s	f	“	£	³	Ã	Ó	ã	ó
4	\$	4	D	T	d	t	„	”	¼	´	Ä	Ô	ä	ô
5	%	5	E	U	e	u	...	•	¥	μ	Å	Ö	å	ö
6	&	6	F	V	f	v	†	-		¶	Æ	Ö	æ	ö
7	'	7	G	W	g	w	‡	—	§	·	Ç	×	ç	÷
8	(8	H	X	h	x	^	~	ˆ	˜	È	Ø	è	ø
9)	9	I	Y	i	y	‰	™	©	¹	É	Ù	é	ù
A	*	:	J	Z	j	z	Š	š	ª	º	Ê	Ú	ê	ú
B	+	;	K	[k	{	<	>	«	»	Ë	Û	ë	û
C	,	<	L	\	l		Œ	œ	¬	¼	Ï	Ü	ï	ü
D	-	=	M	J	m	}			-	½	Í	İ	í	ı
E	.	>	N	^	n	~			®	¾	Î	Ş	î	ş
F	/	?	O	_	o	☒		ÿ	˘	˙	İ	ß	ï	ÿ

(12) PC-1257

	2	3	4	5	6	7	8	9	A	B	C	D	E	F
0		0	@	P	`	p	€		°	Ą	Ś	ą	ś	
1	!	1	A	Q	a	q		‘	±	Į	Ń	į	ń	
2	"	2	B	R	b	r	,	’	²	Ā	Ņ	ā	ņ	
3	#	3	C	S	c	s		“	£	³	Ć	Ó	ć	ó
4	\$	4	D	T	d	t	„	”	¼	´	Ä	Ö	ä	ö
5	%	5	E	U	e	u	...	•		μ	Å	Ö	å	ö
6	&	6	F	V	f	v	†	-		¶	Ę	Ö	ę	ö
7	'	7	G	W	g	w	‡	—	§	·	Ę	×	ę	÷
8	(8	H	X	h	x			Ø	ø	Č	U	č	u
9)	9	I	Y	i	y	‰	™	©	¹	É	Ł	é	ł
A	*	:	J	Z	j	z			Ŕ	ř	Ž	Ś	ř	ś
B	+	;	K	[k	{	<	>	«	»	Ě	Ů	ě	ů
C	,	<	L	\	l				¬	¼	Ĝ	Ü	ĝ	ü
D	-	=	M	J	m	}	ˆ	˜	-	½	Ķ	Ž	ķ	ž
E	.	>	N	^	n	~	˘	˙	˚	¾	Ī	Ž	ī	ž
F	/	?	O	_	o	☒			Æ	æ	Ł	ß	ł	·

(13) LATIN9

	2	3	4	5	6	7	8	9	A	B	C	D	E	F
0		0	@	P	`	p			°	À	Ð	à	ð	
1	!	1	A	Q	a	q			ı	±	Á	Ñ	á	ñ
2	"	2	B	R	b	r			¢	²	Â	Ò	â	ò
3	#	3	C	S	c	s			£	³	Ã	Ó	ã	ó
4	\$	4	D	T	d	t			€	Ž	Ä	Ô	ä	ô
5	%	5	E	U	e	u			¥	μ	Å	Ö	å	ö
6	&	6	F	V	f	v			Š	¶	Æ	Ö	æ	ö
7	'	7	G	W	g	w			§	·	Ç	×	ç	÷
8	(8	H	X	h	x			š	ž	È	Ø	è	ø
9)	9	I	Y	i	y			©	¹	É	Ù	é	ù
A	*	:	J	Z	j	z			ª	º	Ê	Ú	ê	ú
B	+	;	K	[k	{			«	»	Ë	Û	ë	û
C	,	<	L	\	l				¬	œ	Ì	Ü	ì	ü
D	-	=	M]	m	}			-	æ	Í	Ý	í	ý
E	.	>	N	^	n	~			®	ÿ	Î	Þ	î	þ
F	/	?	O	_	o	☒			-	ı	İ	ß	ï	ÿ

(14) ARABIC

	2	3	4	5	6	7	8	9	A	B	C	D	E	F
0		،	ء	ت	ا	ع			ع	ؤ	.	ء		
1		-	=	ث	ل	ع			ل	ى	لا	ء		
2		.	'	ث	د	ع			ل	ء	لا	ء		
3		/	؟	ج	-	غ			م	ث	لأ	ء		
4		.	—	ج	ز	ع			م	ث	لأ	ء		
5	!	١	ا	س	ج	غ			ت	0	لأ	ء		
6	"	٢	ا	س	ح	غ			هـ	1	لأ	ء	الله	
7	«	٣	أ	س	ج	ف			+	2	لأ	ء	ن	
8	»	٤	أ	س	ح	ف			هـ	3	لأ	ء		
9	%	٥	آ	ص	ح	ف			هـ	4	لأ	ء		
A	x	٦	آ	ص	ح	ف			و	5	لأ	ء		
B	÷	٧	!	ض	خ	ف			بـ	6	لأ	ء		
C	(٨	ل	د	ض	ف			ي	7	لأ	ء		
D)	٩	بـ	ذ	ط	ك			ي	8	لأ	ء		
E	*	:	ر	بـ	ظ	ك			ة	9	لأ	ء		
F	+	٤	ث	[ع				ة	ئ	لأ	ء		

12. BAR CODE TABLE

(1) WPC (JAN, EAN, UPC)
ITF, MSI, UCC/EAN128, Industrial 2 of 5

	2	3	4	5	6	7
0		0				
1		1				
2		2				
3		3				
4		4				
5		5				
6		6				
7		7				
8		8				
9		9				
A						
B						
C						
D						
E						
F						

(2) CODE39 (Standard)

	2	3	4	5	6	7
0	SP	0		P		
1		1	A	Q		
2		2	B	R		
3		3	C	S		
4	\$	4	D	T		
5	%	5	E	U		
6		6	F	V		
7		7	G	W		
8		8	H	X		
9		9	I	Y		
A	.		J	Z		
B	+		K			
C			L			
D	-		M			
E	•		N			
F	/		O			

(3) CODE39 (Full ASCII)

[Transfer code]

	2	3	4	5	6	7
0	SP	0	@	P	`	p
1	!	1	A	Q	a	q
2	"	2	B	R	b	r
3	#	3	C	S	c	s
4	\$	4	D	T	d	t
5	%	5	E	U	e	u
6	&	6	F	V	f	v
7	'	7	G	W	g	w
8	(8	H	X	h	x
9)	9	I	Y	i	y
A	*	:	J	Z	j	z
B	+	;	K	[k	{
C	,	<	L	\	l	
D	-	=	M]	m	}
E	.	>	N	^	n	~
F	/	?	O	_	o	△

[Drawing code]

	2	3	4	5	6	7
0	SP	0	%V	P	%W	+P
1	/A	1	A	Q	+A	+Q
2	/B	2	B	R	+B	+R
3	/C	3	C	S	+C	+S
4	/D	4	D	T	+D	+T
5	/E	5	E	U	+E	+U
6	/F	6	F	V	+F	+V
7	/G	7	G	W	+G	+W
8	/H	8	H	X	+H	+X
9	/I	9	I	Y	+I	+Y
A	/J	/Z	J	Z	+J	+Z
B	/K	%F	K	%K	+K	%P
C	/L	%G	L	%L	+L	%Q
D	-	%H	M	%M	+M	%R
E	.	%I	N	%N	+N	%S
F	/O	%J	O	%O	+O	%T



(4) NW-7

	2	3	4	5	6	7
0	SP	0				
1		1	A		a	
2		2	B		b	
3		3	C		c	
4	\$	4	D		d	t
5		5			e	
6		6				
7		7				
8		8				
9		9				
A	*	:				
B	+					
C						
D	-					
E	•				n	
F	/					

(5) CODE93

[Transfer code]

	2	3	4	5	6	7
0	SP	0	@	P	`	p
1	!	1	A	Q	a	q
2	"	2	B	R	b	r
3	#	3	C	S	c	s
4	\$	4	D	T	d	t
5	%	5	E	U	e	u
6	&	6	F	V	f	v
7	'	7	G	W	g	w
8	(8	H	X	h	x
9)	9	I	Y	i	y
A	*	:	J	Z	j	z
B	+	;	K	[k	{
C	,	<	L	\	l	
D	-	=	M]	m	}
E	.	>	N	^	n	~
F	/	?	O	_	o	△

[Drawing code]

	2	3	4	5	6	7
0	SP	0	%V	P	%W	+P
1	/A	1	A	Q	+A	+Q
2	/B	2	B	R	+B	+R
3	/C	3	C	S	+C	+S
4	\$	4	D	T	+D	+T
5	%	5	E	U	+E	+U
6	/F	6	F	V	+F	+V
7	/G	7	G	W	+G	+W
8	/H	8	H	X	+H	+X
9	/I	9	I	Y	+I	+Y
A	/J	/Z	J	Z	+J	+Z
B	+	%F	K	%K	+K	%P
C	/L	%G	L	%L	+L	%Q
D	-	%H	M	%M	+M	%R
E	.	%I	N	%N	+N	%S
F	/	%J	O	%O	+O	%T



(6) CODE128

[Transfer code]

	-	-	2	3	4	5	6	7
0	NUL	DLE	SP	0	@	P	`	p
1	SOH	DC1	!	1	A	Q	a	q
2	STX	DC2	"	2	B	R	b	r
3	ETX	DC3	#	3	C	S	c	s
4	EOT	DC4	\$	4	D	T	d	t
5	ENQ	NAK	%	5	E	U	e	u
6	ACK	SYN	&	6	F	V	f	v
7	BEL	ETB	'	7	G	W	g	w
8	BS	CAN	(8	H	X	h	x
9	HT	EM)	9	I	Y	i	y
A	LF	SUB	.	:	J	Z	j	z
B	VT	ESC	+	;	K	[k	{
C	FF	FS	,	<	L	\	l	
D	CR	GS	-	=	M]	m	}
E	SO	RS	.	>	N	^	n	~
F	SI	US	/	?	O	_	o	△

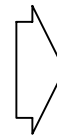

[Drawing code]

Value Code Table

① How to transmit control code data:

NUL (00H) → >@ (3EH, 40H)
 SOH (01H) → >A (3EH, 41H)
 STX (02H) → >B (3EH, 42H)
 to
 GS (1DH) → >] (3EH, 5DH)
 RS (1EH) → >^ (3EH, 5EH)
 US (1FH) → >_ (3EH, 5FH)

② How to transmit special codes:

Value
 30 (Character >) → >0
 95 → >1
 96 → >2
 97 → >3
 98 → >4
 99 → >5
 100 → >6
 101 → >7
 102 → >8

③ Designation of start code:

START (CODE A) → >7
 START (CODE B) → >6
 START (CODE C) → >5

Value Code Table

VALUE	CODE A	CODE B	CODE C
0	SP	SP	00
1	!	!	01
2	"	"	02
3	#	#	03
4	\$	\$	04
5	%	%	05
6	&	&	06
7	'	'	07
8	((08
9))	09
10	*	*	10
11	+	+	11
12	,	,	12
13	-	-	13
14	.	.	14
15	/	/	15
16	0	0	16
17	1	1	17
18	2	2	18
19	3	3	19
20	4	4	20
21	5	5	21
22	6	6	22
23	7	7	23
24	8	8	24
25	9	9	25
26	:	:	26
27	;	;	27
28	<	<	28
29	=	=	29
30	>	>	30
31	?	?	31
32	@	@	32
33	A	A	33
34	B	B	34
35	C	C	35
36	D	D	36
37	E	E	37
38	F	F	38
39	G	G	39
40	H	H	40
41	I	I	41
42	J	J	42
43	K	K	43
44	L	L	44
45	M	M	45
46	N	N	46
47	O	O	47
48	P	P	48
49	Q	Q	49
50	R	R	50
51	S	S	51
52	T	T	52
53	U	U	53
54	V	V	54
55	W	W	55
56	X	X	56
57	Y	Y	57
58	Z	Z	58
59	[[59
60	\	\	60
61]]	61
62	^	^	62
63	_	_	63
64	NUL	`	64
65	SOH	a	65
66	STX	b	66
67	ETX	c	67
68	EOT	d	68
69	ENQ	e	69
70	ACK	f	70
71	BEL	g	71
72	BS	h	72
73	HT	i	73
74	LF	j	74
75	VT	k	75
76	FF	l	76
77	CR	m	77
78	SO	n	78
79	SI	o	79
80	DLE	p	80
81	DC1	q	81
82	DC2	r	82
83	DC3	s	83
84	DC4	t	84
85	NAK	u	85
86	SYN	v	86
87	ETB	w	87
88	CAN	x	88
89	EM	y	89
90	SUB	z	90
91	ESC	{	91
92	FS		92
93	GS	}	93
94	RS	~	94
95	US	DEL	95
96	FNC3	FNC3	96
97	FNC2	FNC2	97
98	SHIFT	SHIFT	98
99	CODE C	CODE C	99
100	CODE B	FNC4	CODE B
101	FNC4	CODE A	CODE A
102	FNC1	FNC1	FNC1
103	START CODE A		
104	START CODE B		
105	START CODE C		

(7) Data Matrix

The code to be used is designated using the format ID.

Format ID	Code	Details
1	Numerics	0 to 9 space
2	Letters	A to Z space
3	Alphanumerics, symbols	0 to 9 A to Z space . , - /
4	Alphanumerics	0 to 9 A to Z space
5	ASCII (7-bit)	00H to 7FH
6	ISO (8-bit)	00H to FFH (Kanji)
11	Numerics	0 to 9 space
12	Letters	A to Z space
13	Alphanumerics, symbols	0 to 9 A to Z space . , - /
14	Alphanumerics	0 to 9 A to Z space
15	ASCII (7-bit)	00H to 7FH
16	ISO (8-bit)	00H to FFH (Kanji)

[Transfer Code]

	0	1	2	3	4	5	6	7	8	9	A	B	C	D	E	F
0	NUL	DLE	SP	0	@	P	`	p								
1	SOH	DC1	!	1	A	Q	a	q								
2	STX	DC2	"	2	B	R	b	r								
3	ETX	DC3	#	3	C	S	c	s								
4	EOT	DC4	\$	4	D	T	d	t								
5	ENQ	NAK	%	5	E	U	e	u								
6	ACK	SYN	&	6	F	V	f	v								
7	BEL	ETB	'	7	G	W	g	w								
8	BS	CAN	(8	H	X	h	x								
9	HT	EM)	9	I	Y	i	y								
A	LF	SUB	*	:	J	Z	j	z								
B	VT	ESC	+	;	K	[k	{								
C	FF	FS	,	<	L	\	l									
D	CR	GS	-	=	M]	m	}								
E	SO	RS	.	>	N	^	n	~								
F	SI	US	/	?	O	_	o	△								

① How to send control code data

NUL (00H) → >@ (3EH, 40H)
 SOH (01H) → >A (3EH, 41H)
 STX (02H) → >B (3EH, 42H)
 to
 GS (1DH) → >] (3EH, 5DH)
 RS (1EH) → >^ (3EH, 5EH)
 US (1FH) → >_ (3EH, 5FH)

② How to send a special code

> (3EH) → >0 (3EH, 30H)

③ How to send a Kanji code

Shift JIS

JIS hexadecimal

(For details, refer to the section for the Bar Code Data Command.)

(8) PDF417

The following modes are automatically selected according to the code used.

Mode	Code	Details
EXC mode	Alphanumerics, symbol	0 to 9 A to Z a to z space ! " # \$ % & ' () * + , - . / : ; < = > ? @ [\] ^ _ ` { } ~ △ CR HT
Binary/ASCII Plus mode	Binary International Character Set	00H to FFH (Kanji)
Numeric Compaction mode	Numerics	0 to 9

[Transfer Code]

	0	1	2	3	4	5	6	7	8	9	A	B	C	D	E	F
0	NUL	DLE	SP	0	@	P	`	p								
1	SOH	DC1	!	1	A	Q	a	q								
2	STX	DC2	"	2	B	R	b	r								
3	ETX	DC3	#	3	C	S	c	s								
4	EOT	DC4	\$	4	D	T	d	t								
5	ENQ	NAK	%	5	E	U	e	u								
6	ACK	SYN	&	6	F	V	f	v								
7	BEL	ETB	'	7	G	W	g	w								
8	BS	CAN	(8	H	X	h	x								
9	HT	EM)	9	I	Y	i	y								
A	LF	SUB	*	:	J	Z	j	z								
B	VT	ESC	+	;	K	[k	{								
C	FF	FS	,	<	L	\	l									
D	CR	GS	-	=	M]	m	}								
E	SO	RS	.	>	N	^	n	~								
F	SI	US	/	?	O	_	o	△								

① How to send control code data

NUL (00H) → >@ (3EH, 40H)
 SOH (01H) → >A (3EH, 41H)
 STX (02H) → >B (3EH, 42H)
 to
 GS (1DH) → >] (3EH, 5DH)
 RS (1EH) → >^ (3EH, 5EH)
 US (1FH) → >_ (3EH, 5FH)

② How to send a special code

> (3EH) → >0 (3EH, 30H)

③ How to send a Kanji code

Shift JIS

JIS hexadecimal

(For details, refer to the section for the Bar Code Data Command.)

(9) QR code

When manual mode is selected in the Format Command

- Numeric mode, alphanumeric and symbol mode, Kanji mode

Mode selection	Data to be printed
----------------	--------------------

- Binary mode

Mode selection	No. of data strings (4 digits)	Data to be printed
----------------	-----------------------------------	--------------------

- Mixed mode

Data	“,” (comma)	Data	“,” (comma)	Data
------	-------------	------	-------------	------

The QR code can handle all codes including alphanumerics, symbols and Kanji. Since the data compression rate varies according to codes, the code to be used is designated when the mode is selected.

Mode	Code	Details
N	Numerals	0 to 9
A	Alphanumerics, symbols	A to Z 0 to 9 space \$ % * + - . / :
B	Binary (8-bit)	00H to FFH
K	Kanji	Shift JIS, JIS hexadecimal

If mixed mode is selected, up to 200 modes can be selected in a QR code.

When the automatic mode is selected in the Format Command for a QR code:

Data to be printed

[Transfer code for QR code]

	0	1	2	3	4	5	6	7	8	9	A	B	C	D	E	F
0	NUL	DLE	SP	0	@	P	`	p								
1	SOH	DC1	!	1	A	Q	a	q								
2	STX	DC2	"	2	B	R	b	r								
3	ETX	DC3	#	3	C	S	c	s								
4	EOT	DC4	\$	4	D	T	d	t								
5	ENQ	NAK	%	5	E	U	e	u								
6	ACK	SYN	&	6	F	V	f	v								
7	BEL	ETB	'	7	G	W	g	w								
8	BS	CAN	(8	H	X	h	x								
9	HT	EM)	9	I	Y	i	y								
A	LF	SUB	*	:	J	Z	j	z								
B	VT	ESC	+	;	K	[k	{								
C	FF	FS	,	<	L	\	l									
D	CR	GS	-	=	M]	m	}								
E	SO	RS	•	>	N	^	n	~								
F	SI	US	/	?	O	_	o	DEL								

* The shaded parts are Japanese. They are omitted here.

- ① How to send control code data
- NUL (00H) → >@ (3EH, 40H)
 SOH (01H) → >A (3EH, 41H)
 STX (02H) → >B (3EH, 42H)
 to
 GS (1DH) → >] (3EH, 5DH)
 RS (1EH) → >^ (3EH, 5EH)
 US (1FH) → >_ (3EH, 5FH)
- ② How to send a special code
- > (3EH) → >0 (3EH, 30H)

Examples of data designation for QR code

- ① Alphanumeric mode: ABC123

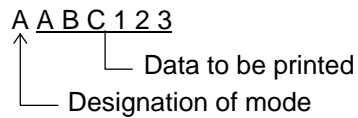

- ② Binary mode: 01H, 03H, 05H

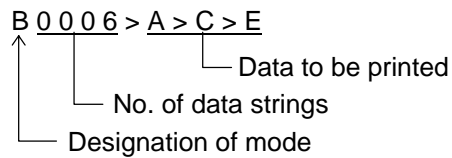

- ③ Mixed mode

Numeric mode : 123456
 Kanji mode : Kanji data
 Binary mode : aア iイ uウ eエ oオ
 Alphanumeric and symbol mode : ABC

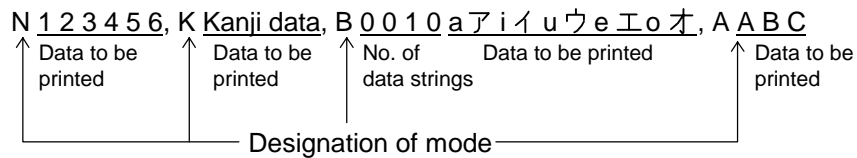

- ④ Automatic mode

When the same data as ③ above is designated in automatic mode:

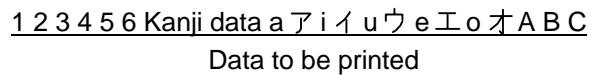

(10) Postal code

Customer bar code

	2	3	4	5	6	
0		0		P		
1		1	A	Q		
2		2	B	R		
3		3	C	S		
4		4	D	T		
5		5	E	U		
6		6	F	V		
7		7	G	W		
8		8	H	X		
9		9	I	Y		
A			J	Z		
B			K			
C			L			
D	-		M			
E			N			
F			O			

POSTNET

	2	3	4	5	6	7
0		0				
1		1				
2		2				
3		3				
4		4				
5		5				
6		6				
7		7				
8		8				
9		9				
A						
B						
C						
D						
E						
F						

RM4SCC

	2	3	4	5	6	
0		0		P		
1		1	A	Q		
2		2	B	R		
3		3	C	S		
4		4	D	T		
5		5	E	U		
6		6	F	V		
7		7	G	W		
8	(8	H	X		
9)	9	I	Y		
A			J	Z		
B			K			
C			L			
D			M			
E			N			
F			O			

KIX CODE

	2	3	4	5	6	7
0		0		P		p
1		1	A	Q	a	q
2		2	B	R	b	r
3		3	C	S	c	s
4		4	D	T	d	t
5		5	E	U	e	u
6		6	F	V	f	v
7		7	G	W	g	w
8		8	H	X	h	x
9		9	I	Y	i	y
A			J	Z	j	z
B			K		k	
C			L		l	
D			M		m	
E			N		n	
F			O		o	

* (“(” or “)”) can be designated only as a start/stop code.
 These should not be entered in data.
 If these are entered between data, no bar code is drawn.

(11) MaxiCode

Symbol Character Value		Code Set A		Code Set B		Code Set C		Code Set D		Code Set E	
Decimal	Binary	Character	Decimal	Character	Decimal	Character	Decimal	Character	Decimal	Character	Decimal
0	000000	CR	13	'	96	À	192	à	224	NUL	0
1	000001	A	65	a	97	Á	193	á	225	SOH	1
2	000010	B	66	b	98	Â	194	â	226	STX	2
3	000011	C	67	c	99	Ã	195	ã	227	ETX	3
4	000100	D	68	d	100	Ä	196	ä	228	EOT	4
5	000101	E	69	e	101	Å	197	å	229	ENQ	5
6	000110	F	70	f	102	Æ	198	æ	230	ACK	6
7	000111	G	71	g	103	Ç	199	ç	231	BEL	7
8	001000	H	72	h	104	È	200	è	232	BS	8
9	001001	I	73	i	105	É	201	é	233	HT	9
10	001010	J	74	j	106	Ê	202	ê	234	LF	10
11	001011	K	75	k	107	Ë	203	ë	235	VT	11
12	001100	L	76	l	108	Ì	204	ì	236	FF	12
13	001101	M	77	m	109	Í	205	í	237	CR	13
14	001110	N	78	n	110	Î	206	î	238	SO	14
15	001111	O	79	o	111	Ï	207	ï	239	SI	15
16	010000	P	80	p	112	Ð	208	ð	240	DLE	16
17	010001	Q	81	q	113	Ñ	209	ñ	241	DC1	17
18	010010	R	82	r	114	Ò	210	ò	242	DC2	18
19	010011	S	83	s	115	Ó	211	ó	243	DC3	19
20	010100	T	84	t	116	Ô	212	ô	244	DC4	20
21	010101	U	85	u	117	Õ	213	õ	245	NAK	21
22	010110	V	86	v	118	Ö	214	ö	246	SYN	22
23	010111	W	87	w	119	×	215	÷	247	ETB	23
24	011000	X	88	x	120	Ø	216	ø	248	CAN	24
25	011001	Y	89	y	121	Ù	217	ù	249	EM	25
26	011010	Z	90	z	122	Ú	218	ú	250	SUB	26
27	011011	[EC]		[EC]		[EC]		[EC]		[EC]	
28	011100	FS	28	FS	28	FS	28	FS	28	[Pad]	
29	011101	GS	29	GS	29	GS	29	GS	29	[Pad]	
30	011110	RS	30	RS	30	RS	30	RS	30	ESC	27
31	011111	[NS]		[NS]		[NS]		[NS]		[NS]	
32	100000	Space	32	(123	Û	219	û	251	FS	28
33	100001	[Pad])	125	Ü	220	ü	252	GS	29
34	100010	"	34	~	126	Ý	221	ý	253	RS	30
35	100011	#	35	DEL	127	Þ	222	þ	254	US	31
36	100100	\$	36	;	59	ß	223	ÿ	255	{C159}	159
37	100101	%	37	<	60	à	170	ÿ	161	NBSP	160
38	100110	&	38	=	61	ı	172	ı	168	¢	162
39	100111	'	39	>	62	±	177	«	171	£	163
40	101000	(40	?	63	²	178	¬	175	¤	164
41	101001)	41	[91	³	179	°	176	¥	165
42	101010	"	42	\	92	´	181	´	180	¦	166
43	101011	+	43]	93	µ	185	•	183	§	167
44	101100	,	44	^	94	¶	186	•	184	©	169
45	101101	-	45	_	95	¼	188	»	187	SHY	173
46	101110	.	46	Space	32	½	189	¿	191	®	174
47	101111	/	47	,	44	¾	190	{C138}	138	¶	182
48	110000	0	48	.	46	{C128}	128	{C139}	139	{C149}	149
49	110001	1	49	/	47	{C129}	129	{C140}	140	{C150}	150
50	110010	2	50	:	58	{C130}	130	{C141}	141	{C151}	151
51	110011	3	51	@	64	{C131}	131	{C142}	142	{C152}	152
52	110100	4	52	!	33	{C132}	132	{C143}	143	{C153}	153
53	110101	5	53		124	{C133}	133	{C144}	144	{C154}	154
54	110110	6	54	[Pad]		{C134}	134	{C145}	145	{C155}	155
55	110111	7	55	[2 Shift A]		{C135}	135	{C146}	146	{C156}	156
56	111000	8	56	[3 Shift A]		{C136}	136	{C147}	147	{C157}	157
57	111001	9	57	[Pad]		{C137}	137	{C148}	148	{C158}	158
58	111010	:	58	[Latch A]		[Latch A]		[Latch A]		[Latch A]	
59	111011	[Shift B]		[Shift A]		Space	32	Space	32	Space	32
60	111100	[Shift C]		[Shift C]		[Lock In C]		[Shift C]		[Shift C]	
61	111101	[Shift D]		[Shift D]		[Shift D]		[Lock In D]		[Shift D]	
62	111110	[Shift E]		[Shift E]		[Shift E]		[Shift E]		[Lock In E]	
63	111111	[Latch B]		[Latch A]		[Latch B]		[Latch B]		[Latch B]	

① How to send control code data

SOH (01H)	→	>A	(3EH, 41H)
STX (02H)	→	>B	(3EH, 42H)
to			
GS (1DH)	→	>]	(3EH, 5DH)
RS (1EH)	→	>^	(3EH, 5EH)
US (1FH)	→	>_	(3EH, 5FH)

② How to send a special code

>	(3EH)	→	>0	(3EH, 30H)
---	-------	---	----	------------

NOTE: *NUL data in the table cannot be used*

(12) MicroPDF417

The following modes are automatically selected according to the code used.

Mode	Details
Upper case letters, space	A to Z, space
Binary International Character Set	00H to FFH (Kanji)
Numerics	0 to 9

[Transfer Code]

	0	1	2	3	4	5	6	7	8	9	A	B	C	D	E	F
0	NUL	DLE	SP	0	@	P	`	p								
1	SOH	DC1	!	1	A	Q	a	q								
2	STX	DC2	"	2	B	R	b	r								
3	ETX	DC3	#	3	C	S	c	s								
4	EOT	DC4	\$	4	D	T	d	t								
5	ENQ	NAK	%	5	E	U	e	u								
6	ACK	SYN	&	6	F	V	f	v								
7	BEL	ETB	'	7	G	W	g	w								
8	BS	CAN	(8	H	X	h	x								
9	HT	EM)	9	I	Y	i	y								
A	LF	SUB	*	:	J	Z	j	z								
B	VT	ESC	+	;	K	[k	{								
C	FF	FS	,	<	L	\	l									
D	CR	GS	-	=	M]	m	}								
E	SO	RS	.	>	N	^	n	~								
F	SI	US	/	?	O	_	o	△								

① How to send control code data

NUL (00H) → >@ (3EH, 40H)
 SOH (01H) → >A (3EH, 41H)
 STX (02H) → >B (3EH, 42H)
 to
 GS (1DH) → >] (3EH, 5DH)
 RS (1EH) → >^ (3EH, 5EH)
 US (1FH) → >_ (3EH, 5FH)

② How to send a special code

> (3EH) → >0 (3EH, 30H)

③ How to send a Kanji code

Shift JIS

JIS hexadecimal

(For details, refer to the section for the Bar Code Data Command.)

13. DRAWING OF BAR CODE DATA

- : Field to be incremented/decremented
(The absence of a solid line invalidates incrementing/decrementing.)
- : Field subject to printing numerals under bars.

Type of Bar Code: JAN8, EAN8

(1) No affix

No. of Input Digits										
8 digits	Input Data	<table border="1" style="display: inline-table;"> <tr> <td>D₁</td><td>D₂</td><td>D₃</td><td>D₄</td><td>D₅</td><td>D₆</td><td>D₇</td><td>D₈</td> </tr> </table> └─ To be checked as modulus 10 C/D	D ₁	D ₂	D ₃	D ₄	D ₅	D ₆	D ₇	D ₈
	D ₁	D ₂	D ₃	D ₄	D ₅	D ₆	D ₇	D ₈		
Drawing Data	<table border="1" style="display: inline-table;"> <tr> <td>D₁</td><td>D₂</td><td>D₃</td><td>D₄</td><td>D₅</td><td>D₆</td><td>D₇</td><td>D₈</td> </tr> </table>	D ₁	D ₂	D ₃	D ₄	D ₅	D ₆	D ₇	D ₈	
D ₁	D ₂	D ₃	D ₄	D ₅	D ₆	D ₇	D ₈			
Other than 8 digits		Not to be drawn								

(2) Modulus 10 check

No. of Input Digits										
8 digits	Input Data	<table border="1" style="display: inline-table;"> <tr> <td>D₁</td><td>D₂</td><td>D₃</td><td>D₄</td><td>D₅</td><td>D₆</td><td>D₇</td><td>D₈</td> </tr> </table> └─ To be checked as modulus 10 C/D	D ₁	D ₂	D ₃	D ₄	D ₅	D ₆	D ₇	D ₈
	D ₁	D ₂	D ₃	D ₄	D ₅	D ₆	D ₇	D ₈		
Drawing Data	<table border="1" style="display: inline-table;"> <tr> <td>D₁</td><td>D₂</td><td>D₃</td><td>D₄</td><td>D₅</td><td>D₆</td><td>D₇</td><td>D₈</td> </tr> </table>	D ₁	D ₂	D ₃	D ₄	D ₅	D ₆	D ₇	D ₈	
D ₁	D ₂	D ₃	D ₄	D ₅	D ₆	D ₇	D ₈			
Other than 8 digits		Not to be drawn								

(3) Auto affix of modulus 10

No. of Input Digits									
7 digits	Input Data	<table border="1" style="display: inline-table;"> <tr> <td>D₁</td><td>D₂</td><td>D₃</td><td>D₄</td><td>D₅</td><td>D₆</td><td>D₇</td> </tr> </table>	D ₁	D ₂	D ₃	D ₄	D ₅	D ₆	D ₇
	D ₁	D ₂	D ₃	D ₄	D ₅	D ₆	D ₇		
Drawing Data	<table border="1" style="display: inline-table;"> <tr> <td>D₁</td><td>D₂</td><td>D₃</td><td>D₄</td><td>D₅</td><td>D₆</td><td>D₇</td><td>C/D</td> </tr> </table> └─ Affix a modulus 10 C/D.	D ₁	D ₂	D ₃	D ₄	D ₅	D ₆	D ₇	C/D
D ₁	D ₂	D ₃	D ₄	D ₅	D ₆	D ₇	C/D		
Other than 7 digits		Not to be drawn							

Type of Bar Code: JAN13, EAN13

(1) No affix

No. of Input Digits															
13 digits	Input Data	<table border="1"> <tr> <td>D₁</td><td>D₂</td><td>D₃</td><td>D₄</td><td>D₅</td><td>D₆</td><td>D₇</td><td>D₈</td><td>D₉</td><td>D₁₀</td><td>D₁₁</td><td>D₁₂</td><td>D₁₃</td> </tr> </table>	D ₁	D ₂	D ₃	D ₄	D ₅	D ₆	D ₇	D ₈	D ₉	D ₁₀	D ₁₁	D ₁₂	D ₁₃
	D ₁	D ₂	D ₃	D ₄	D ₅	D ₆	D ₇	D ₈	D ₉	D ₁₀	D ₁₁	D ₁₂	D ₁₃		
Drawing Data	<table border="1"> <tr> <td>D₂</td><td>D₃</td><td>D₄</td><td>D₅</td><td>D₆</td><td>D₇</td><td>D₈</td><td>D₉</td><td>D₁₀</td><td>D₁₁</td><td>D₁₂</td><td>D₁₃</td> </tr> </table>	D ₂	D ₃	D ₄	D ₅	D ₆	D ₇	D ₈	D ₉	D ₁₀	D ₁₁	D ₁₂	D ₁₃		
D ₂	D ₃	D ₄	D ₅	D ₆	D ₇	D ₈	D ₉	D ₁₀	D ₁₁	D ₁₂	D ₁₃				
Other than 13 digits		Not to be drawn													

(2) Modulus 10 check

No. of Input Digits															
13 digits	Input Data	<table border="1"> <tr> <td>D₁</td><td>D₂</td><td>D₃</td><td>D₄</td><td>D₅</td><td>D₆</td><td>D₇</td><td>D₈</td><td>D₉</td><td>D₁₀</td><td>D₁₁</td><td>D₁₂</td><td>D₁₃</td> </tr> </table>	D ₁	D ₂	D ₃	D ₄	D ₅	D ₆	D ₇	D ₈	D ₉	D ₁₀	D ₁₁	D ₁₂	D ₁₃
	D ₁	D ₂	D ₃	D ₄	D ₅	D ₆	D ₇	D ₈	D ₉	D ₁₀	D ₁₁	D ₁₂	D ₁₃		
Drawing Data	<table border="1"> <tr> <td>D₂</td><td>D₃</td><td>D₄</td><td>D₅</td><td>D₆</td><td>D₇</td><td>D₈</td><td>D₉</td><td>D₁₀</td><td>D₁₁</td><td>D₁₂</td><td>D₁₃</td> </tr> </table>	D ₂	D ₃	D ₄	D ₅	D ₆	D ₇	D ₈	D ₉	D ₁₀	D ₁₁	D ₁₂	D ₁₃		
D ₂	D ₃	D ₄	D ₅	D ₆	D ₇	D ₈	D ₉	D ₁₀	D ₁₁	D ₁₂	D ₁₃				
Other than 13 digits		Not to be drawn													

(3) Auto affix of modulus 10

No. of Input Digits														
12 digits	Input Data	<table border="1"> <tr> <td>D₁</td><td>D₂</td><td>D₃</td><td>D₄</td><td>D₅</td><td>D₆</td><td>D₇</td><td>D₈</td><td>D₉</td><td>D₁₀</td><td>D₁₁</td><td>D₁₂</td> </tr> </table>	D ₁	D ₂	D ₃	D ₄	D ₅	D ₆	D ₇	D ₈	D ₉	D ₁₀	D ₁₁	D ₁₂
	D ₁	D ₂	D ₃	D ₄	D ₅	D ₆	D ₇	D ₈	D ₉	D ₁₀	D ₁₁	D ₁₂		
Drawing Data	<table border="1"> <tr> <td>D₂</td><td>D₃</td><td>D₄</td><td>D₅</td><td>D₆</td><td>D₇</td><td>D₈</td><td>D₉</td><td>D₁₀</td><td>D₁₁</td><td>D₁₂</td><td>C/D</td> </tr> </table>	D ₂	D ₃	D ₄	D ₅	D ₆	D ₇	D ₈	D ₉	D ₁₀	D ₁₁	D ₁₂	C/D	
D ₂	D ₃	D ₄	D ₅	D ₆	D ₇	D ₈	D ₉	D ₁₀	D ₁₁	D ₁₂	C/D			
Other than 12 digits		Not to be drawn												

(4) Auto affix of modulus 10 + price C/D 4 digits

No. of Input Digits													
11 digits	Input Data	<table border="1"> <tr> <td>D₁</td><td>D₂</td><td>D₃</td><td>D₄</td><td>D₅</td><td>D₆</td><td>D₇</td><td>D₈</td><td>D₉</td><td>D₁₀</td><td>D₁₁</td> </tr> </table>	D ₁	D ₂	D ₃	D ₄	D ₅	D ₆	D ₇	D ₈	D ₉	D ₁₀	D ₁₁
	D ₁	D ₂	D ₃	D ₄	D ₅	D ₆	D ₇	D ₈	D ₉	D ₁₀	D ₁₁		
Drawing Data	<table border="1"> <tr> <td>D₂</td><td>D₃</td><td>D₄</td><td>D₅</td><td>D₆</td><td>D₇</td><td>P/CD</td><td>D₈</td><td>D₉</td><td>D₁₀</td><td>D₁₁</td><td>C/D</td> </tr> </table>	D ₂	D ₃	D ₄	D ₅	D ₆	D ₇	P/CD	D ₈	D ₉	D ₁₀	D ₁₁	C/D
D ₂	D ₃	D ₄	D ₅	D ₆	D ₇	P/CD	D ₈	D ₉	D ₁₀	D ₁₁	C/D		
Other than 11 digits		Not to be drawn											

(5) Auto affix of modulus 10 + price C/D 5 digits

No. of Input Digits													
11 digits	Input Data	<table border="1"> <tr> <td>D₁</td><td>D₂</td><td>D₃</td><td>D₄</td><td>D₅</td><td>D₆</td><td>D₇</td><td>D₈</td><td>D₉</td><td>D₁₀</td><td>D₁₁</td> </tr> </table>	D ₁	D ₂	D ₃	D ₄	D ₅	D ₆	D ₇	D ₈	D ₉	D ₁₀	D ₁₁
	D ₁	D ₂	D ₃	D ₄	D ₅	D ₆	D ₇	D ₈	D ₉	D ₁₀	D ₁₁		
Drawing Data	<table border="1"> <tr> <td>D₂</td><td>D₃</td><td>D₄</td><td>D₅</td><td>D₆</td><td>P/CD</td><td>D₇</td><td>D₈</td><td>D₉</td><td>D₁₀</td><td>D₁₁</td><td>C/D</td> </tr> </table>	D ₂	D ₃	D ₄	D ₅	D ₆	P/CD	D ₇	D ₈	D ₉	D ₁₀	D ₁₁	C/D
D ₂	D ₃	D ₄	D ₅	D ₆	P/CD	D ₇	D ₈	D ₉	D ₁₀	D ₁₁	C/D		
Other than 11 digits		Not to be drawn											

Type of Bar Code: UPC-A

(1) No affix

No. of Input Digits														
12 digits	Input Data	<table border="1"> <tr> <td>D₁</td><td>D₂</td><td>D₃</td><td>D₄</td><td>D₅</td><td>D₆</td><td>D₇</td><td>D₈</td><td>D₉</td><td>D₁₀</td><td>D₁₁</td><td>D₁₂</td> </tr> </table> <p style="text-align: center;">To be checked as modulus 10 C/D</p>	D ₁	D ₂	D ₃	D ₄	D ₅	D ₆	D ₇	D ₈	D ₉	D ₁₀	D ₁₁	D ₁₂
	D ₁	D ₂	D ₃	D ₄	D ₅	D ₆	D ₇	D ₈	D ₉	D ₁₀	D ₁₁	D ₁₂		
Drawing Data	<table border="1"> <tr> <td>D₁</td><td>D₂</td><td>D₃</td><td>D₄</td><td>D₅</td><td>D₆</td><td>D₇</td><td>D₈</td><td>D₉</td><td>D₁₀</td><td>D₁₁</td><td>D₁₂</td> </tr> </table>	D ₁	D ₂	D ₃	D ₄	D ₅	D ₆	D ₇	D ₈	D ₉	D ₁₀	D ₁₁	D ₁₂	
D ₁	D ₂	D ₃	D ₄	D ₅	D ₆	D ₇	D ₈	D ₉	D ₁₀	D ₁₁	D ₁₂			
Other than 12 digits		Not to be drawn												

(2) Modulus 10 check

No. of Input Digits														
12 digits	Input Data	<table border="1"> <tr> <td>D₁</td><td>D₂</td><td>D₃</td><td>D₄</td><td>D₅</td><td>D₆</td><td>D₇</td><td>D₈</td><td>D₉</td><td>D₁₀</td><td>D₁₁</td><td>D₁₂</td> </tr> </table> <p style="text-align: center;">To be checked as modulus 10 C/D</p>	D ₁	D ₂	D ₃	D ₄	D ₅	D ₆	D ₇	D ₈	D ₉	D ₁₀	D ₁₁	D ₁₂
	D ₁	D ₂	D ₃	D ₄	D ₅	D ₆	D ₇	D ₈	D ₉	D ₁₀	D ₁₁	D ₁₂		
Drawing Data	<table border="1"> <tr> <td>D₁</td><td>D₂</td><td>D₃</td><td>D₄</td><td>D₅</td><td>D₆</td><td>D₇</td><td>D₈</td><td>D₉</td><td>D₁₀</td><td>D₁₁</td><td>D₁₂</td> </tr> </table>	D ₁	D ₂	D ₃	D ₄	D ₅	D ₆	D ₇	D ₈	D ₉	D ₁₀	D ₁₁	D ₁₂	
D ₁	D ₂	D ₃	D ₄	D ₅	D ₆	D ₇	D ₈	D ₉	D ₁₀	D ₁₁	D ₁₂			
Other than 12 digits		Not to be drawn												

(3) Auto affix of modulus 10

No. of Input Digits													
11 digits	Input Data	<table border="1"> <tr> <td>D₁</td><td>D₂</td><td>D₃</td><td>D₄</td><td>D₅</td><td>D₆</td><td>D₇</td><td>D₈</td><td>D₉</td><td>D₁₀</td><td>D₁₁</td> </tr> </table>	D ₁	D ₂	D ₃	D ₄	D ₅	D ₆	D ₇	D ₈	D ₉	D ₁₀	D ₁₁
	D ₁	D ₂	D ₃	D ₄	D ₅	D ₆	D ₇	D ₈	D ₉	D ₁₀	D ₁₁		
Drawing Data	<table border="1"> <tr> <td>D₁</td><td>D₂</td><td>D₃</td><td>D₄</td><td>D₅</td><td>D₆</td><td>D₇</td><td>D₈</td><td>D₉</td><td>D₁₀</td><td>D₁₁</td><td>C/D</td> </tr> </table> <p style="text-align: right;">Affix a modulus 10 C/D.</p>	D ₁	D ₂	D ₃	D ₄	D ₅	D ₆	D ₇	D ₈	D ₉	D ₁₀	D ₁₁	C/D
D ₁	D ₂	D ₃	D ₄	D ₅	D ₆	D ₇	D ₈	D ₉	D ₁₀	D ₁₁	C/D		
Other than 11 digits		Not to be drawn											

(4) Auto affix of modulus 10 + price C/D 4 digits

No. of Input Digits													
10 digits	Input Data	<table border="1"> <tr> <td>D₁</td><td>D₂</td><td>D₃</td><td>D₄</td><td>D₅</td><td>D₆</td><td>D₇</td><td>D₈</td><td>D₉</td><td>D₁₀</td> </tr> </table>	D ₁	D ₂	D ₃	D ₄	D ₅	D ₆	D ₇	D ₈	D ₉	D ₁₀	
	D ₁	D ₂	D ₃	D ₄	D ₅	D ₆	D ₇	D ₈	D ₉	D ₁₀			
Drawing Data	<table border="1"> <tr> <td>D₁</td><td>D₂</td><td>D₃</td><td>D₄</td><td>D₅</td><td>D₆</td><td>P/CD</td><td>D₇</td><td>D₈</td><td>D₉</td><td>D₁₀</td><td>C/D</td> </tr> </table> <p style="text-align: right;">Affix price C/D 4 digits.</p> <p style="text-align: right;">Affix a modulus 10 C/D.</p>	D ₁	D ₂	D ₃	D ₄	D ₅	D ₆	P/CD	D ₇	D ₈	D ₉	D ₁₀	C/D
D ₁	D ₂	D ₃	D ₄	D ₅	D ₆	P/CD	D ₇	D ₈	D ₉	D ₁₀	C/D		
Other than 10 digits		Not to be drawn											

(5) Auto affix of modulus 10 + price C/D 5 digits

No. of Input Digits													
10 digits	Input Data	<table border="1"> <tr> <td>D₁</td><td>D₂</td><td>D₃</td><td>D₄</td><td>D₅</td><td>D₆</td><td>D₇</td><td>D₈</td><td>D₉</td><td>D₁₀</td> </tr> </table>	D ₁	D ₂	D ₃	D ₄	D ₅	D ₆	D ₇	D ₈	D ₉	D ₁₀	
	D ₁	D ₂	D ₃	D ₄	D ₅	D ₆	D ₇	D ₈	D ₉	D ₁₀			
Drawing Data	<table border="1"> <tr> <td>D₁</td><td>D₂</td><td>D₃</td><td>D₄</td><td>D₅</td><td>P/CD</td><td>D₆</td><td>D₇</td><td>D₈</td><td>D₉</td><td>D₁₀</td><td>C/D</td> </tr> </table> <p style="text-align: right;">Affix price C/D 5 digits.</p> <p style="text-align: right;">Affix a modulus 10 C/D.</p>	D ₁	D ₂	D ₃	D ₄	D ₅	P/CD	D ₆	D ₇	D ₈	D ₉	D ₁₀	C/D
D ₁	D ₂	D ₃	D ₄	D ₅	P/CD	D ₆	D ₇	D ₈	D ₉	D ₁₀	C/D		
Other than 10 digits		Not to be drawn											

Type of Bar Code: UPC-E

(1) No affix

No. of Input Digits									
7 digits	Input Data	<table border="1" style="display: inline-table; vertical-align: middle;"> <tr> <td>D₁</td><td>D₂</td><td>D₃</td><td>D₄</td><td>D₅</td><td>D₆</td><td>D₇</td> </tr> </table> └─ To be checked as modulus 10 C/D	D ₁	D ₂	D ₃	D ₄	D ₅	D ₆	D ₇
	D ₁	D ₂	D ₃	D ₄	D ₅	D ₆	D ₇		
Drawing Data	<table border="1" style="display: inline-table; vertical-align: middle;"> <tr> <td>0</td><td>D₁</td><td>D₂</td><td>D₃</td><td>D₄</td><td>D₅</td><td>D₆</td><td>D₇</td> </tr> </table>	0	D ₁	D ₂	D ₃	D ₄	D ₅	D ₆	D ₇
0	D ₁	D ₂	D ₃	D ₄	D ₅	D ₆	D ₇		
Other than 7 digits		Not to be drawn							

(2) Modulus 10 check

No. of Input Digits									
7 digits	Input Data	<table border="1" style="display: inline-table; vertical-align: middle;"> <tr> <td>D₁</td><td>D₂</td><td>D₃</td><td>D₄</td><td>D₅</td><td>D₆</td><td>D₇</td> </tr> </table> └─ To be checked as modulus 10 C/D	D ₁	D ₂	D ₃	D ₄	D ₅	D ₆	D ₇
	D ₁	D ₂	D ₃	D ₄	D ₅	D ₆	D ₇		
Drawing Data	<table border="1" style="display: inline-table; vertical-align: middle;"> <tr> <td>0</td><td>D₁</td><td>D₂</td><td>D₃</td><td>D₄</td><td>D₅</td><td>D₆</td><td>D₇</td> </tr> </table>	0	D ₁	D ₂	D ₃	D ₄	D ₅	D ₆	D ₇
0	D ₁	D ₂	D ₃	D ₄	D ₅	D ₆	D ₇		
Other than 7 digits		Not to be drawn							

(3) Auto affix of modulus 10

No. of Input Digits									
6 digits	Input Data	<table border="1" style="display: inline-table; vertical-align: middle;"> <tr> <td>D₁</td><td>D₂</td><td>D₃</td><td>D₄</td><td>D₅</td><td>D₆</td> </tr> </table> Calculate and reflect modulus 10 in the bar code.	D ₁	D ₂	D ₃	D ₄	D ₅	D ₆	
	D ₁	D ₂	D ₃	D ₄	D ₅	D ₆			
Drawing Data	<table border="1" style="display: inline-table; vertical-align: middle;"> <tr> <td>0</td><td>D₁</td><td>D₂</td><td>D₃</td><td>D₄</td><td>D₅</td><td>D₆</td><td>C/D</td> </tr> </table>	0	D ₁	D ₂	D ₃	D ₄	D ₅	D ₆	C/D
0	D ₁	D ₂	D ₃	D ₄	D ₅	D ₆	C/D		
Other than 6 digits		Not to be drawn							

Type of Bar Code: JAN8 +2 digits, EAN8 + 2 digits

(1) No affix

No. of Input Digits												
10 digits	Input Data	<table border="1"> <tr> <td>D₁</td><td>D₂</td><td>D₃</td><td>D₄</td><td>D₅</td><td>D₆</td><td>D₇</td><td>D₈</td><td>D₉</td><td>D₁₀</td> </tr> </table> <p style="text-align: right;">└─ To be checked as modulus 10 C/D</p>	D ₁	D ₂	D ₃	D ₄	D ₅	D ₆	D ₇	D ₈	D ₉	D ₁₀
	D ₁	D ₂	D ₃	D ₄	D ₅	D ₆	D ₇	D ₈	D ₉	D ₁₀		
Drawing Data	<table border="1"> <tr> <td>D₁</td><td>D₂</td><td>D₃</td><td>D₄</td><td>D₅</td><td>D₆</td><td>D₇</td><td>D₈</td> <td>D₉</td><td>D₁₀</td> </tr> </table>	D ₁	D ₂	D ₃	D ₄	D ₅	D ₆	D ₇	D ₈	D ₉	D ₁₀	
D ₁	D ₂	D ₃	D ₄	D ₅	D ₆	D ₇	D ₈	D ₉	D ₁₀			
Other than 10 digits		Not to be drawn										

(2) Modulus 10 check

No. of Input Digits												
10 digits	Input Data	<table border="1"> <tr> <td>D₁</td><td>D₂</td><td>D₃</td><td>D₄</td><td>D₅</td><td>D₆</td><td>D₇</td><td>D₈</td><td>D₉</td><td>D₁₀</td> </tr> </table> <p style="text-align: right;">└─ To be checked as modulus 10 C/D</p>	D ₁	D ₂	D ₃	D ₄	D ₅	D ₆	D ₇	D ₈	D ₉	D ₁₀
	D ₁	D ₂	D ₃	D ₄	D ₅	D ₆	D ₇	D ₈	D ₉	D ₁₀		
Drawing Data	<table border="1"> <tr> <td>D₁</td><td>D₂</td><td>D₃</td><td>D₄</td><td>D₅</td><td>D₆</td><td>D₇</td><td>D₈</td> <td>D₉</td><td>D₁₀</td> </tr> </table>	D ₁	D ₂	D ₃	D ₄	D ₅	D ₆	D ₇	D ₈	D ₉	D ₁₀	
D ₁	D ₂	D ₃	D ₄	D ₅	D ₆	D ₇	D ₈	D ₉	D ₁₀			
Other than 10 digits		Not to be drawn										

(3) Auto affix of modulus 10

No. of Input Digits											
9 digits	Input Data	<table border="1"> <tr> <td>D₁</td><td>D₂</td><td>D₃</td><td>D₄</td><td>D₅</td><td>D₆</td><td>D₇</td><td>D₈</td><td>D₉</td> </tr> </table>	D ₁	D ₂	D ₃	D ₄	D ₅	D ₆	D ₇	D ₈	D ₉
	D ₁	D ₂	D ₃	D ₄	D ₅	D ₆	D ₇	D ₈	D ₉		
Drawing Data	<table border="1"> <tr> <td>D₁</td><td>D₂</td><td>D₃</td><td>D₄</td><td>D₅</td><td>D₆</td><td>D₇</td><td>C/D</td> <td>D₈</td><td>D₉</td> </tr> </table> <p style="text-align: right;">└─ Affix a modulus 10 C/D.</p>	D ₁	D ₂	D ₃	D ₄	D ₅	D ₆	D ₇	C/D	D ₈	D ₉
D ₁	D ₂	D ₃	D ₄	D ₅	D ₆	D ₇	C/D	D ₈	D ₉		
Other than 9 digits		Not to be drawn									

Type of Bar Code: JAN8 +5 digits, EAN8 + 5 digits

(1) No affix

No. of Input Digits															
13 digits	Input Data	<table border="1"> <tr> <td>D₁</td><td>D₂</td><td>D₃</td><td>D₄</td><td>D₅</td><td>D₆</td><td>D₇</td><td>D₈</td><td>D₉</td><td>D₁₀</td><td>D₁₁</td><td>D₁₂</td><td>D₁₃</td> </tr> </table> <p style="text-align: right;">└─ To be checked as modulus 10 C/D</p>	D ₁	D ₂	D ₃	D ₄	D ₅	D ₆	D ₇	D ₈	D ₉	D ₁₀	D ₁₁	D ₁₂	D ₁₃
	D ₁	D ₂	D ₃	D ₄	D ₅	D ₆	D ₇	D ₈	D ₉	D ₁₀	D ₁₁	D ₁₂	D ₁₃		
Drawing Data	<table border="1"> <tr> <td>D₁</td><td>D₂</td><td>D₃</td><td>D₄</td><td>D₅</td><td>D₆</td><td>D₇</td><td>D₈</td> <td>D₉</td><td>D₁₀</td><td>D₁₁</td><td>D₁₂</td><td>D₁₃</td> </tr> </table>	D ₁	D ₂	D ₃	D ₄	D ₅	D ₆	D ₇	D ₈	D ₉	D ₁₀	D ₁₁	D ₁₂	D ₁₃	
D ₁	D ₂	D ₃	D ₄	D ₅	D ₆	D ₇	D ₈	D ₉	D ₁₀	D ₁₁	D ₁₂	D ₁₃			
Other than 13 digits		Not to be drawn													

(2) Modulus 10 check

No. of Input Digits															
13 digits	Input Data	<table border="1"> <tr> <td>D₁</td><td>D₂</td><td>D₃</td><td>D₄</td><td>D₅</td><td>D₆</td><td>D₇</td><td>D₈</td><td>D₉</td><td>D₁₀</td><td>D₁₁</td><td>D₁₂</td><td>D₁₃</td> </tr> </table> <p style="text-align: right;">└─ To be checked as modulus 10 C/D</p>	D ₁	D ₂	D ₃	D ₄	D ₅	D ₆	D ₇	D ₈	D ₉	D ₁₀	D ₁₁	D ₁₂	D ₁₃
	D ₁	D ₂	D ₃	D ₄	D ₅	D ₆	D ₇	D ₈	D ₉	D ₁₀	D ₁₁	D ₁₂	D ₁₃		
Drawing Data	<table border="1"> <tr> <td>D₁</td><td>D₂</td><td>D₃</td><td>D₄</td><td>D₅</td><td>D₆</td><td>D₇</td><td>D₈</td> <td>D₉</td><td>D₁₀</td><td>D₁₁</td><td>D₁₂</td><td>D₁₃</td> </tr> </table>	D ₁	D ₂	D ₃	D ₄	D ₅	D ₆	D ₇	D ₈	D ₉	D ₁₀	D ₁₁	D ₁₂	D ₁₃	
D ₁	D ₂	D ₃	D ₄	D ₅	D ₆	D ₇	D ₈	D ₉	D ₁₀	D ₁₁	D ₁₂	D ₁₃			
Other than 13 digits		Not to be drawn													

(3) Auto affix of modulus 10

No. of Input Digits														
12 digits	Input Data	<table border="1"> <tr> <td>D₁</td><td>D₂</td><td>D₃</td><td>D₄</td><td>D₅</td><td>D₆</td><td>D₇</td><td>D₈</td><td>D₉</td><td>D₁₀</td><td>D₁₁</td><td>D₁₂</td> </tr> </table>	D ₁	D ₂	D ₃	D ₄	D ₅	D ₆	D ₇	D ₈	D ₉	D ₁₀	D ₁₁	D ₁₂
	D ₁	D ₂	D ₃	D ₄	D ₅	D ₆	D ₇	D ₈	D ₉	D ₁₀	D ₁₁	D ₁₂		
Drawing Data	<table border="1"> <tr> <td>D₁</td><td>D₂</td><td>D₃</td><td>D₄</td><td>D₅</td><td>D₆</td><td>D₇</td><td>C/D</td> <td>D₈</td><td>D₉</td><td>D₁₀</td><td>D₁₁</td><td>D₁₂</td> </tr> </table> <p style="text-align: right;">└─ Affix a modulus 10 C/D.</p>	D ₁	D ₂	D ₃	D ₄	D ₅	D ₆	D ₇	C/D	D ₈	D ₉	D ₁₀	D ₁₁	D ₁₂
D ₁	D ₂	D ₃	D ₄	D ₅	D ₆	D ₇	C/D	D ₈	D ₉	D ₁₀	D ₁₁	D ₁₂		
Other than 12 digits		Not to be drawn												

Type of Bar Code: JAN13 +2 digits, EAN13 + 2 digits

(1) No affix

No. of Input Digits		
15 digits	Input Data	D ₁ D ₂ D ₃ D ₄ D ₅ D ₆ D ₇ D ₈ D ₉ D ₁₀ D ₁₁ D ₁₂ D ₁₃ D ₁₄ D ₁₅
	Drawing Data	D ₂ D ₃ D ₄ D ₅ D ₆ D ₇ D ₈ D ₉ D ₁₀ D ₁₁ D ₁₂ D ₁₃ D ₁₄ D ₁₅
Other than 15 digits		Not to be drawn

(2) Modulus 10 check

No. of Input Digits		
15 digits	Input Data	D ₁ D ₂ D ₃ D ₄ D ₅ D ₆ D ₇ D ₈ D ₉ D ₁₀ D ₁₁ D ₁₂ D ₁₃ D ₁₄ D ₁₅
	Drawing Data	D ₂ D ₃ D ₄ D ₅ D ₆ D ₇ D ₈ D ₉ D ₁₀ D ₁₁ D ₁₂ D ₁₃ D ₁₄ D ₁₅
Other than 15 digits		Not to be drawn

(3) Auto affix of modulus 10

No. of Input Digits		
14 digits	Input Data	D ₁ D ₂ D ₃ D ₄ D ₅ D ₆ D ₇ D ₈ D ₉ D ₁₀ D ₁₁ D ₁₂ D ₁₃ D ₁₄
	Drawing Data	D ₂ D ₃ D ₄ D ₅ D ₆ D ₇ D ₈ D ₉ D ₁₀ D ₁₁ D ₁₂ C/D D ₁₃ D ₁₄
Other than 14 digits		Not to be drawn

(4) Auto affix of modulus 10 + price C/D 4 digits

No. of Input Digits		
13 digits	Input Data	D ₁ D ₂ D ₃ D ₄ D ₅ D ₆ D ₇ D ₈ D ₉ D ₁₀ D ₁₁ D ₁₂ D ₁₃
	Drawing Data	D ₂ D ₃ D ₄ D ₅ D ₆ D ₇ P/CD D ₈ D ₉ D ₁₀ D ₁₁ C/D D ₁₂ D ₁₃
Other than 13 digits		Not to be drawn

(5) Auto affix of modulus 10 + price C/D 5 digits

No. of Input Digits		
13 digits	Input Data	D ₁ D ₂ D ₃ D ₄ D ₅ D ₆ D ₇ D ₈ D ₉ D ₁₀ D ₁₁ D ₁₂ D ₁₃
	Drawing Data	D ₂ D ₃ D ₄ D ₅ D ₆ P/CD D ₇ D ₈ D ₉ D ₁₀ D ₁₁ C/D D ₁₂ D ₁₃
Other than 13 digits		Not to be drawn

Type of Bar Code: JAN13 +5 digits, EAN13 + 5 digits

(1) No affix

No. of Input Digits		
18 digits	Input Data	D ₁ D ₂ D ₃ D ₄ D ₅ D ₆ D ₇ D ₈ D ₉ D ₁₀ D ₁₁ D ₁₂ D ₁₃ D ₁₄ D ₁₅ D ₁₆ D ₁₇ D ₁₈
	Drawing Data	<div style="border: 1px solid black; padding: 2px; display: inline-block;"> D₂ D₃ D₄ D₅ D₆ D₇ D₈ D₉ D₁₀ D₁₁ D₁₂ D₁₃ D₁₄ D₁₅ D₁₆ D₁₇ D₁₈ </div>
Other than 18 digits		Not to be drawn

(2) Modulus 10 check

No. of Input Digits		
18 digits	Input Data	D ₁ D ₂ D ₃ D ₄ D ₅ D ₆ D ₇ D ₈ D ₉ D ₁₀ D ₁₁ D ₁₂ D ₁₃ D ₁₄ D ₁₅ D ₁₆ D ₁₇ D ₁₈
	Drawing Data	<div style="border: 1px solid black; padding: 2px; display: inline-block;"> D₂ D₃ D₄ D₅ D₆ D₇ D₈ D₉ D₁₀ D₁₁ D₁₂ D₁₃ D₁₄ D₁₅ D₁₆ D₁₇ D₁₈ </div>
Other than 18 digits		Not to be drawn

(3) Auto affix of modulus 10

No. of Input Digits		
17 digits	Input Data	D ₁ D ₂ D ₃ D ₄ D ₅ D ₆ D ₇ D ₈ D ₉ D ₁₀ D ₁₁ D ₁₂ D ₁₃ D ₁₄ D ₁₅ D ₁₆ D ₁₇
	Drawing Data	<div style="border: 1px solid black; padding: 2px; display: inline-block;"> D₂ D₃ D₄ D₅ D₆ D₇ D₈ D₉ D₁₀ D₁₁ D₁₂ C/D D₁₃ D₁₄ D₁₅ D₁₆ D₁₇ </div>
Other than 17 digits		Not to be drawn

(4) Auto affix of modulus 10 + price C/D 4 digits

No. of Input Digits		
16 digits	Input Data	D ₁ D ₂ D ₃ D ₄ D ₅ D ₆ D ₇ D ₈ D ₉ D ₁₀ D ₁₁ D ₁₂ D ₁₃ D ₁₄ D ₁₅ D ₁₆
	Drawing Data	<div style="border: 1px solid black; padding: 2px; display: inline-block;"> D₂ D₃ D₄ D₅ D₆ D₇ P/CD D₈ D₉ D₁₀ D₁₁ C/D D₁₂ D₁₃ D₁₄ D₁₅ D₁₆ </div>
Other than 16 digits		Not to be drawn

(5) Auto affix of modulus 10 + price C/D 5 digits

No. of Input Digits		
16 digits	Input Data	D ₁ D ₂ D ₃ D ₄ D ₅ D ₆ D ₇ D ₈ D ₉ D ₁₀ D ₁₁ D ₁₂ D ₁₃ D ₁₄ D ₁₅ D ₁₆
	Drawing Data	<div style="border: 1px solid black; padding: 2px; display: inline-block;"> D₂ D₃ D₄ D₅ D₆ P/CD D₇ D₈ D₉ D₁₀ D₁₁ C/D D₁₂ D₁₃ D₁₄ D₁₅ D₁₆ </div>
Other than 16 digits		Not to be drawn

Type of Bar Code: UPC-A + 2 digits

(1) No affix

No. of Input Digits																
14 digits	Input Data	<table border="1" style="display: inline-table; border-collapse: collapse;"> <tr> <td>D₁</td><td>D₂</td><td>D₃</td><td>D₄</td><td>D₅</td><td>D₆</td><td>D₇</td><td>D₈</td><td>D₉</td><td>D₁₀</td><td>D₁₁</td><td>D₁₂</td><td>D₁₃</td><td>D₁₄</td> </tr> </table> <p style="text-align: center;">To be checked as modulus 10 C/D</p>	D ₁	D ₂	D ₃	D ₄	D ₅	D ₆	D ₇	D ₈	D ₉	D ₁₀	D ₁₁	D ₁₂	D ₁₃	D ₁₄
	D ₁	D ₂	D ₃	D ₄	D ₅	D ₆	D ₇	D ₈	D ₉	D ₁₀	D ₁₁	D ₁₂	D ₁₃	D ₁₄		
Drawing Data	<table border="1" style="display: inline-table; border-collapse: collapse;"> <tr> <td>D₁</td><td>D₂</td><td>D₃</td><td>D₄</td><td>D₅</td><td>D₆</td><td>D₇</td><td>D₈</td><td>D₉</td><td>D₁₀</td><td>D₁₁</td><td>D₁₂</td> <td style="border: 1px solid black; padding: 2px;">D₁₃</td><td style="border: 1px solid black; padding: 2px;">D₁₄</td> </tr> </table>	D ₁	D ₂	D ₃	D ₄	D ₅	D ₆	D ₇	D ₈	D ₉	D ₁₀	D ₁₁	D ₁₂	D ₁₃	D ₁₄	
D ₁	D ₂	D ₃	D ₄	D ₅	D ₆	D ₇	D ₈	D ₉	D ₁₀	D ₁₁	D ₁₂	D ₁₃	D ₁₄			
Other than 14 digits		Not to be drawn														

(2) Modulus 10 check

No. of Input Digits																
14 digits	Input Data	<table border="1" style="display: inline-table; border-collapse: collapse;"> <tr> <td>D₁</td><td>D₂</td><td>D₃</td><td>D₄</td><td>D₅</td><td>D₆</td><td>D₇</td><td>D₈</td><td>D₉</td><td>D₁₀</td><td>D₁₁</td><td>D₁₂</td><td>D₁₃</td><td>D₁₄</td> </tr> </table> <p style="text-align: center;">To be checked as modulus 10 C/D</p>	D ₁	D ₂	D ₃	D ₄	D ₅	D ₆	D ₇	D ₈	D ₉	D ₁₀	D ₁₁	D ₁₂	D ₁₃	D ₁₄
	D ₁	D ₂	D ₃	D ₄	D ₅	D ₆	D ₇	D ₈	D ₉	D ₁₀	D ₁₁	D ₁₂	D ₁₃	D ₁₄		
Drawing Data	<table border="1" style="display: inline-table; border-collapse: collapse;"> <tr> <td>D₁</td><td>D₂</td><td>D₃</td><td>D₄</td><td>D₅</td><td>D₆</td><td>D₇</td><td>D₈</td><td>D₉</td><td>D₁₀</td><td>D₁₁</td><td>D₁₂</td> <td style="border: 1px solid black; padding: 2px;">D₁₃</td><td style="border: 1px solid black; padding: 2px;">D₁₄</td> </tr> </table>	D ₁	D ₂	D ₃	D ₄	D ₅	D ₆	D ₇	D ₈	D ₉	D ₁₀	D ₁₁	D ₁₂	D ₁₃	D ₁₄	
D ₁	D ₂	D ₃	D ₄	D ₅	D ₆	D ₇	D ₈	D ₉	D ₁₀	D ₁₁	D ₁₂	D ₁₃	D ₁₄			
Other than 14 digits		Not to be drawn														

(3) Auto affix of modulus 10

No. of Input Digits															
13 digits	Input Data	<table border="1" style="display: inline-table; border-collapse: collapse;"> <tr> <td>D₁</td><td>D₂</td><td>D₃</td><td>D₄</td><td>D₅</td><td>D₆</td><td>D₇</td><td>D₈</td><td>D₉</td><td>D₁₀</td><td>D₁₁</td><td>D₁₂</td><td>D₁₃</td> </tr> </table>	D ₁	D ₂	D ₃	D ₄	D ₅	D ₆	D ₇	D ₈	D ₉	D ₁₀	D ₁₁	D ₁₂	D ₁₃
	D ₁	D ₂	D ₃	D ₄	D ₅	D ₆	D ₇	D ₈	D ₉	D ₁₀	D ₁₁	D ₁₂	D ₁₃		
Drawing Data	<table border="1" style="display: inline-table; border-collapse: collapse;"> <tr> <td>D₁</td><td>D₂</td><td>D₃</td><td>D₄</td><td>D₅</td><td>D₆</td><td>D₇</td><td>D₈</td><td>D₉</td><td>D₁₀</td><td>D₁₁</td><td style="border: 1px solid black; padding: 2px;">C/D</td> <td style="border: 1px solid black; padding: 2px;">D₁₂</td><td style="border: 1px solid black; padding: 2px;">D₁₃</td> </tr> </table> <p style="text-align: right;">Affix a modulus 10 C/D.</p>	D ₁	D ₂	D ₃	D ₄	D ₅	D ₆	D ₇	D ₈	D ₉	D ₁₀	D ₁₁	C/D	D ₁₂	D ₁₃
D ₁	D ₂	D ₃	D ₄	D ₅	D ₆	D ₇	D ₈	D ₉	D ₁₀	D ₁₁	C/D	D ₁₂	D ₁₃		
Other than 13 digits		Not to be drawn													

(4) Auto affix of modulus 10 + price C/D 4 digits

No. of Input Digits															
12 digits	Input Data	<table border="1" style="display: inline-table; border-collapse: collapse;"> <tr> <td>D₁</td><td>D₂</td><td>D₃</td><td>D₄</td><td>D₅</td><td>D₆</td><td>D₇</td><td>D₈</td><td>D₉</td><td>D₁₀</td><td>D₁₁</td><td>D₁₂</td> </tr> </table>	D ₁	D ₂	D ₃	D ₄	D ₅	D ₆	D ₇	D ₈	D ₉	D ₁₀	D ₁₁	D ₁₂	
	D ₁	D ₂	D ₃	D ₄	D ₅	D ₆	D ₇	D ₈	D ₉	D ₁₀	D ₁₁	D ₁₂			
Drawing Data	<table border="1" style="display: inline-table; border-collapse: collapse;"> <tr> <td>D₁</td><td>D₂</td><td>D₃</td><td>D₄</td><td>D₅</td><td>D₆</td><td style="border: 1px solid black; padding: 2px;">P/CD</td><td>D₇</td><td>D₈</td><td>D₉</td><td>D₁₀</td><td style="border: 1px solid black; padding: 2px;">C/D</td> <td style="border: 1px solid black; padding: 2px;">D₁₁</td><td style="border: 1px solid black; padding: 2px;">D₁₂</td> </tr> </table> <p style="text-align: right;">Affix price C/D 4 digits. Affix a modulus 10 C/D.</p>	D ₁	D ₂	D ₃	D ₄	D ₅	D ₆	P/CD	D ₇	D ₈	D ₉	D ₁₀	C/D	D ₁₁	D ₁₂
D ₁	D ₂	D ₃	D ₄	D ₅	D ₆	P/CD	D ₇	D ₈	D ₉	D ₁₀	C/D	D ₁₁	D ₁₂		
Other than 12 digits		Not to be drawn													

(5) Auto affix of modulus 10 + price C/D 5 digits

No. of Input Digits															
12 digits	Input Data	<table border="1" style="display: inline-table; border-collapse: collapse;"> <tr> <td>D₁</td><td>D₂</td><td>D₃</td><td>D₄</td><td>D₅</td><td>D₆</td><td>D₇</td><td>D₈</td><td>D₉</td><td>D₁₀</td><td>D₁₁</td><td>D₁₂</td> </tr> </table>	D ₁	D ₂	D ₃	D ₄	D ₅	D ₆	D ₇	D ₈	D ₉	D ₁₀	D ₁₁	D ₁₂	
	D ₁	D ₂	D ₃	D ₄	D ₅	D ₆	D ₇	D ₈	D ₉	D ₁₀	D ₁₁	D ₁₂			
Drawing Data	<table border="1" style="display: inline-table; border-collapse: collapse;"> <tr> <td>D₁</td><td>D₂</td><td>D₃</td><td>D₄</td><td>D₅</td><td style="border: 1px solid black; padding: 2px;">P/CD</td><td>D₆</td><td>D₇</td><td>D₈</td><td>D₉</td><td>D₁₀</td><td style="border: 1px solid black; padding: 2px;">C/D</td> <td style="border: 1px solid black; padding: 2px;">D₁₁</td><td style="border: 1px solid black; padding: 2px;">D₁₂</td> </tr> </table> <p style="text-align: right;">Affix price C/D 5 digits. Affix a modulus 10 C/D.</p>	D ₁	D ₂	D ₃	D ₄	D ₅	P/CD	D ₆	D ₇	D ₈	D ₉	D ₁₀	C/D	D ₁₁	D ₁₂
D ₁	D ₂	D ₃	D ₄	D ₅	P/CD	D ₆	D ₇	D ₈	D ₉	D ₁₀	C/D	D ₁₁	D ₁₂		
Other than 12 digits		Not to be drawn													

Type of Bar Code: UPC-A + 5 digits

(1) No affix

No. of Input Digits																			
17 digits	Input Data	<table border="1" style="display: inline-table; border-collapse: collapse;"> <tr> <td>D₁</td><td>D₂</td><td>D₃</td><td>D₄</td><td>D₅</td><td>D₆</td><td>D₇</td><td>D₈</td><td>D₉</td><td>D₁₀</td><td>D₁₁</td><td>D₁₂</td><td>D₁₃</td><td>D₁₄</td><td>D₁₅</td><td>D₁₆</td><td>D₁₇</td> </tr> </table> <p style="text-align: center;">To be checked as modulus 10 C/D</p>	D ₁	D ₂	D ₃	D ₄	D ₅	D ₆	D ₇	D ₈	D ₉	D ₁₀	D ₁₁	D ₁₂	D ₁₃	D ₁₄	D ₁₅	D ₁₆	D ₁₇
	D ₁	D ₂	D ₃	D ₄	D ₅	D ₆	D ₇	D ₈	D ₉	D ₁₀	D ₁₁	D ₁₂	D ₁₃	D ₁₄	D ₁₅	D ₁₆	D ₁₇		
Drawing Data	<table border="1" style="display: inline-table; border-collapse: collapse;"> <tr> <td>D₁</td><td>D₂</td><td>D₃</td><td>D₄</td><td>D₅</td><td>D₆</td><td>D₇</td><td>D₈</td><td>D₉</td><td>D₁₀</td><td>D₁₁</td><td>D₁₂</td> <td style="margin-left: 20px;">D₁₃</td><td>D₁₄</td><td>D₁₅</td><td>D₁₆</td><td>D₁₇</td> </tr> </table>	D ₁	D ₂	D ₃	D ₄	D ₅	D ₆	D ₇	D ₈	D ₉	D ₁₀	D ₁₁	D ₁₂	D ₁₃	D ₁₄	D ₁₅	D ₁₆	D ₁₇	
D ₁	D ₂	D ₃	D ₄	D ₅	D ₆	D ₇	D ₈	D ₉	D ₁₀	D ₁₁	D ₁₂	D ₁₃	D ₁₄	D ₁₅	D ₁₆	D ₁₇			
Other than 17 digits		Not to be drawn																	

(2) Modulus 10 check

No. of Input Digits																			
17 digits	Input Data	<table border="1" style="display: inline-table; border-collapse: collapse;"> <tr> <td>D₁</td><td>D₂</td><td>D₃</td><td>D₄</td><td>D₅</td><td>D₆</td><td>D₇</td><td>D₈</td><td>D₉</td><td>D₁₀</td><td>D₁₁</td><td>D₁₂</td><td>D₁₃</td><td>D₁₄</td><td>D₁₅</td><td>D₁₆</td><td>D₁₇</td> </tr> </table> <p style="text-align: center;">To be checked as modulus 10 C/D</p>	D ₁	D ₂	D ₃	D ₄	D ₅	D ₆	D ₇	D ₈	D ₉	D ₁₀	D ₁₁	D ₁₂	D ₁₃	D ₁₄	D ₁₅	D ₁₆	D ₁₇
	D ₁	D ₂	D ₃	D ₄	D ₅	D ₆	D ₇	D ₈	D ₉	D ₁₀	D ₁₁	D ₁₂	D ₁₃	D ₁₄	D ₁₅	D ₁₆	D ₁₇		
Drawing Data	<table border="1" style="display: inline-table; border-collapse: collapse;"> <tr> <td>D₁</td><td>D₂</td><td>D₃</td><td>D₄</td><td>D₅</td><td>D₆</td><td>D₇</td><td>D₈</td><td>D₉</td><td>D₁₀</td><td>D₁₁</td><td>D₁₂</td> <td style="margin-left: 20px;">D₁₃</td><td>D₁₄</td><td>D₁₅</td><td>D₁₆</td><td>D₁₇</td> </tr> </table>	D ₁	D ₂	D ₃	D ₄	D ₅	D ₆	D ₇	D ₈	D ₉	D ₁₀	D ₁₁	D ₁₂	D ₁₃	D ₁₄	D ₁₅	D ₁₆	D ₁₇	
D ₁	D ₂	D ₃	D ₄	D ₅	D ₆	D ₇	D ₈	D ₉	D ₁₀	D ₁₁	D ₁₂	D ₁₃	D ₁₄	D ₁₅	D ₁₆	D ₁₇			
Other than 17 digits		Not to be drawn																	

(3) Auto affix of modulus 10

No. of Input Digits																		
16 digits	Input Data	<table border="1" style="display: inline-table; border-collapse: collapse;"> <tr> <td>D₁</td><td>D₂</td><td>D₃</td><td>D₄</td><td>D₅</td><td>D₆</td><td>D₇</td><td>D₈</td><td>D₉</td><td>D₁₀</td><td>D₁₁</td><td>D₁₂</td><td>D₁₃</td><td>D₁₄</td><td>D₁₅</td><td>D₁₆</td> </tr> </table>	D ₁	D ₂	D ₃	D ₄	D ₅	D ₆	D ₇	D ₈	D ₉	D ₁₀	D ₁₁	D ₁₂	D ₁₃	D ₁₄	D ₁₅	D ₁₆
	D ₁	D ₂	D ₃	D ₄	D ₅	D ₆	D ₇	D ₈	D ₉	D ₁₀	D ₁₁	D ₁₂	D ₁₃	D ₁₄	D ₁₅	D ₁₆		
Drawing Data	<table border="1" style="display: inline-table; border-collapse: collapse;"> <tr> <td>D₁</td><td>D₂</td><td>D₃</td><td>D₄</td><td>D₅</td><td>D₆</td><td>D₇</td><td>D₈</td><td>D₉</td><td>D₁₀</td><td>D₁₁</td><td>C/D</td> <td style="margin-left: 20px;">D₁₂</td><td>D₁₃</td><td>D₁₄</td><td>D₁₅</td><td>D₁₆</td> </tr> </table> <p style="text-align: right;">Affix a modulus 10 C/D.</p>	D ₁	D ₂	D ₃	D ₄	D ₅	D ₆	D ₇	D ₈	D ₉	D ₁₀	D ₁₁	C/D	D ₁₂	D ₁₃	D ₁₄	D ₁₅	D ₁₆
D ₁	D ₂	D ₃	D ₄	D ₅	D ₆	D ₇	D ₈	D ₉	D ₁₀	D ₁₁	C/D	D ₁₂	D ₁₃	D ₁₄	D ₁₅	D ₁₆		
Other than 16 digits		Not to be drawn																

(4) Auto affix of modulus 10 + price C/D 4 digits

No. of Input Digits																		
15 digits	Input Data	<table border="1" style="display: inline-table; border-collapse: collapse;"> <tr> <td>D₁</td><td>D₂</td><td>D₃</td><td>D₄</td><td>D₅</td><td>D₆</td><td>D₇</td><td>D₈</td><td>D₉</td><td>D₁₀</td><td>D₁₁</td><td>D₁₂</td><td>D₁₃</td><td>D₁₄</td><td>D₁₅</td> </tr> </table>	D ₁	D ₂	D ₃	D ₄	D ₅	D ₆	D ₇	D ₈	D ₉	D ₁₀	D ₁₁	D ₁₂	D ₁₃	D ₁₄	D ₁₅	
	D ₁	D ₂	D ₃	D ₄	D ₅	D ₆	D ₇	D ₈	D ₉	D ₁₀	D ₁₁	D ₁₂	D ₁₃	D ₁₄	D ₁₅			
Drawing Data	<table border="1" style="display: inline-table; border-collapse: collapse;"> <tr> <td>D₁</td><td>D₂</td><td>D₃</td><td>D₄</td><td>D₅</td><td>D₆</td><td>P/CD</td><td>D₇</td><td>D₈</td><td>D₉</td><td>D₁₀</td><td>C/D</td> <td style="margin-left: 20px;">D₁₁</td><td>D₁₂</td><td>D₁₃</td><td>D₁₄</td><td>D₁₅</td> </tr> </table> <p style="text-align: right;">Affix price C/D 4 digits. Affix a modulus 10 C/D.</p>	D ₁	D ₂	D ₃	D ₄	D ₅	D ₆	P/CD	D ₇	D ₈	D ₉	D ₁₀	C/D	D ₁₁	D ₁₂	D ₁₃	D ₁₄	D ₁₅
D ₁	D ₂	D ₃	D ₄	D ₅	D ₆	P/CD	D ₇	D ₈	D ₉	D ₁₀	C/D	D ₁₁	D ₁₂	D ₁₃	D ₁₄	D ₁₅		
Other than 15 digits		Not to be drawn																

(5) Auto affix of modulus 10 + price C/D 5 digits

No. of Input Digits																		
15 digits	Input Data	<table border="1" style="display: inline-table; border-collapse: collapse;"> <tr> <td>D₁</td><td>D₂</td><td>D₃</td><td>D₄</td><td>D₅</td><td>D₆</td><td>D₇</td><td>D₈</td><td>D₉</td><td>D₁₀</td><td>D₁₁</td><td>D₁₂</td><td>D₁₃</td><td>D₁₄</td><td>D₁₅</td> </tr> </table>	D ₁	D ₂	D ₃	D ₄	D ₅	D ₆	D ₇	D ₈	D ₉	D ₁₀	D ₁₁	D ₁₂	D ₁₃	D ₁₄	D ₁₅	
	D ₁	D ₂	D ₃	D ₄	D ₅	D ₆	D ₇	D ₈	D ₉	D ₁₀	D ₁₁	D ₁₂	D ₁₃	D ₁₄	D ₁₅			
Drawing Data	<table border="1" style="display: inline-table; border-collapse: collapse;"> <tr> <td>D₁</td><td>D₂</td><td>D₃</td><td>D₄</td><td>D₅</td><td>P/CD</td><td>D₆</td><td>D₇</td><td>D₈</td><td>D₉</td><td>D₁₀</td><td>C/D</td> <td style="margin-left: 20px;">D₁₁</td><td>D₁₂</td><td>D₁₃</td><td>D₁₄</td><td>D₁₅</td> </tr> </table> <p style="text-align: right;">Affix price C/D 5 digits. Affix a modulus 10 C/D.</p>	D ₁	D ₂	D ₃	D ₄	D ₅	P/CD	D ₆	D ₇	D ₈	D ₉	D ₁₀	C/D	D ₁₁	D ₁₂	D ₁₃	D ₁₄	D ₁₅
D ₁	D ₂	D ₃	D ₄	D ₅	P/CD	D ₆	D ₇	D ₈	D ₉	D ₁₀	C/D	D ₁₁	D ₁₂	D ₁₃	D ₁₄	D ₁₅		
Other than 15 digits		Not to be drawn																

Type of Bar Code: UPC-E + 2 digits

(1) No affix

No. of Input Digits											
9 digits	Input Data	<table border="1" style="display: inline-table; vertical-align: middle;"> <tr> <td>D₁</td><td>D₂</td><td>D₃</td><td>D₄</td><td>D₅</td><td>D₆</td><td>D₇</td><td>D₈</td><td>D₉</td> </tr> </table> └─ To be checked as modulus 10 C/D	D ₁	D ₂	D ₃	D ₄	D ₅	D ₆	D ₇	D ₈	D ₉
	D ₁	D ₂	D ₃	D ₄	D ₅	D ₆	D ₇	D ₈	D ₉		
Drawing Data	<table border="1" style="display: inline-table; vertical-align: middle;"> <tr> <td>0</td><td>D₁</td><td>D₂</td><td>D₃</td><td>D₄</td><td>D₅</td><td>D₆</td><td>D₇</td><td>D₈</td><td>D₉</td> </tr> </table>	0	D ₁	D ₂	D ₃	D ₄	D ₅	D ₆	D ₇	D ₈	D ₉
0	D ₁	D ₂	D ₃	D ₄	D ₅	D ₆	D ₇	D ₈	D ₉		
Other than 9 digits		Not to be drawn									

(2) Modulus 10 check

No. of Input Digits											
9 digits	Input Data	<table border="1" style="display: inline-table; vertical-align: middle;"> <tr> <td>D₁</td><td>D₂</td><td>D₃</td><td>D₄</td><td>D₅</td><td>D₆</td><td>D₇</td><td>D₈</td><td>D₉</td> </tr> </table> └─ To be checked as modulus 10 C/D	D ₁	D ₂	D ₃	D ₄	D ₅	D ₆	D ₇	D ₈	D ₉
	D ₁	D ₂	D ₃	D ₄	D ₅	D ₆	D ₇	D ₈	D ₉		
Drawing Data	<table border="1" style="display: inline-table; vertical-align: middle;"> <tr> <td>0</td><td>D₁</td><td>D₂</td><td>D₃</td><td>D₄</td><td>D₅</td><td>D₆</td><td>D₇</td><td>D₈</td><td>D₉</td> </tr> </table>	0	D ₁	D ₂	D ₃	D ₄	D ₅	D ₆	D ₇	D ₈	D ₉
0	D ₁	D ₂	D ₃	D ₄	D ₅	D ₆	D ₇	D ₈	D ₉		
Other than 9 digits		Not to be drawn									

(3) Auto affix of modulus 10

No. of Input Digits											
8 digits	Input Data	<table border="1" style="display: inline-table; vertical-align: middle;"> <tr> <td>D₁</td><td>D₂</td><td>D₃</td><td>D₄</td><td>D₅</td><td>D₆</td><td>D₇</td><td>D₈</td> </tr> </table> Calculate and reflect modulus 10 C/D in the bar code.	D ₁	D ₂	D ₃	D ₄	D ₅	D ₆	D ₇	D ₈	
	D ₁	D ₂	D ₃	D ₄	D ₅	D ₆	D ₇	D ₈			
Drawing Data	<table border="1" style="display: inline-table; vertical-align: middle;"> <tr> <td>0</td><td>D₁</td><td>D₂</td><td>D₃</td><td>D₄</td><td>D₅</td><td>D₆</td><td>C/D</td><td>D₇</td><td>D₈</td> </tr> </table>	0	D ₁	D ₂	D ₃	D ₄	D ₅	D ₆	C/D	D ₇	D ₈
0	D ₁	D ₂	D ₃	D ₄	D ₅	D ₆	C/D	D ₇	D ₈		
Other than 8 digits		Not to be drawn									

Type of Bar Code: UPC-E + 5 digits

(1) No affix

No. of Input Digits														
12 digits	Input Data	<table border="1" style="display: inline-table; border-collapse: collapse;"> <tr> <td>D₁</td><td>D₂</td><td>D₃</td><td>D₄</td><td>D₅</td><td>D₆</td><td>D₇</td><td>D₈</td><td>D₉</td><td>D₁₀</td><td>D₁₁</td><td>D₁₂</td> </tr> </table> To be checked as modulus 10 C/D	D ₁	D ₂	D ₃	D ₄	D ₅	D ₆	D ₇	D ₈	D ₉	D ₁₀	D ₁₁	D ₁₂
	D ₁	D ₂	D ₃	D ₄	D ₅	D ₆	D ₇	D ₈	D ₉	D ₁₀	D ₁₁	D ₁₂		
Drawing Data	<table border="1" style="display: inline-table; border-collapse: collapse;"> <tr> <td>0</td><td>D₁</td><td>D₂</td><td>D₃</td><td>D₄</td><td>D₅</td><td>D₆</td><td>D₇</td><td>D₈</td><td>D₉</td><td>D₁₀</td><td>D₁₁</td><td>D₁₂</td> </tr> </table>	0	D ₁	D ₂	D ₃	D ₄	D ₅	D ₆	D ₇	D ₈	D ₉	D ₁₀	D ₁₁	D ₁₂
0	D ₁	D ₂	D ₃	D ₄	D ₅	D ₆	D ₇	D ₈	D ₉	D ₁₀	D ₁₁	D ₁₂		
Other than 12 digits		Not to be drawn												

(2) Modulus 10 check

No. of Input Digits														
12 digits	Input Data	<table border="1" style="display: inline-table; border-collapse: collapse;"> <tr> <td>D₁</td><td>D₂</td><td>D₃</td><td>D₄</td><td>D₅</td><td>D₆</td><td>D₇</td><td>D₈</td><td>D₉</td><td>D₁₀</td><td>D₁₁</td><td>D₁₂</td> </tr> </table> To be checked as modulus 10 C/D	D ₁	D ₂	D ₃	D ₄	D ₅	D ₆	D ₇	D ₈	D ₉	D ₁₀	D ₁₁	D ₁₂
	D ₁	D ₂	D ₃	D ₄	D ₅	D ₆	D ₇	D ₈	D ₉	D ₁₀	D ₁₁	D ₁₂		
Drawing Data	<table border="1" style="display: inline-table; border-collapse: collapse;"> <tr> <td>0</td><td>D₁</td><td>D₂</td><td>D₃</td><td>D₄</td><td>D₅</td><td>D₆</td><td>D₇</td><td>D₈</td><td>D₉</td><td>D₁₀</td><td>D₁₁</td><td>D₁₂</td> </tr> </table>	0	D ₁	D ₂	D ₃	D ₄	D ₅	D ₆	D ₇	D ₈	D ₉	D ₁₀	D ₁₁	D ₁₂
0	D ₁	D ₂	D ₃	D ₄	D ₅	D ₆	D ₇	D ₈	D ₉	D ₁₀	D ₁₁	D ₁₂		
Other than 12 digits		Not to be drawn												

(3) Auto affix of modulus 10

No. of Input Digits														
11 digits	Input Data	<table border="1" style="display: inline-table; border-collapse: collapse;"> <tr> <td>D₁</td><td>D₂</td><td>D₃</td><td>D₄</td><td>D₅</td><td>D₆</td><td>D₇</td><td>D₈</td><td>D₉</td><td>D₁₀</td><td>D₁₁</td> </tr> </table> Calculate and reflect modulus 10 C/D in the bar code.	D ₁	D ₂	D ₃	D ₄	D ₅	D ₆	D ₇	D ₈	D ₉	D ₁₀	D ₁₁	
	D ₁	D ₂	D ₃	D ₄	D ₅	D ₆	D ₇	D ₈	D ₉	D ₁₀	D ₁₁			
Drawing Data	<table border="1" style="display: inline-table; border-collapse: collapse;"> <tr> <td>0</td><td>D₁</td><td>D₂</td><td>D₃</td><td>D₄</td><td>D₅</td><td>D₆</td><td>C/D</td><td>D₇</td><td>D₈</td><td>D₉</td><td>D₁₀</td><td>D₁₁</td> </tr> </table>	0	D ₁	D ₂	D ₃	D ₄	D ₅	D ₆	C/D	D ₇	D ₈	D ₉	D ₁₀	D ₁₁
0	D ₁	D ₂	D ₃	D ₄	D ₅	D ₆	C/D	D ₇	D ₈	D ₉	D ₁₀	D ₁₁		
Other than 11 digits		Not to be drawn												

Type of Bar Code: MSI

(1) No affix

No. of Input Digits		
Max. 15 digits	Input Data	D ₁ D ₂ D ₃ D ₄ D ₅ D ₆ D ₇ D ₈ D ₉ Not recognized as a check digit.
	Drawing Data	D ₁ D ₂ D ₃ D ₄ D ₅ D ₆ D ₇ D ₈ D ₉
16 digits or more		Not to be drawn

(2) IBM modulus 10 check

No. of Input Digits		
Min. 2 digits Max. 15 digits (including C/D)	Input Data	D ₁ D ₂ D ₃ D ₄ D ₅ D ₆ D ₇ D ₈ D ₉ D ₁₀ To be checked IBM modulus 10
	Drawing Data	D ₁ D ₂ D ₃ D ₄ D ₅ D ₆ D ₇ D ₈ D ₉ D ₁₀
1 digit 16 digits or more		Not to be drawn

(3) Auto affix of IBM modulus 10

No. of Input Digits		
Max. 14 digits	Input Data	D ₁ D ₂ D ₃ D ₄ D ₅ D ₆ D ₇ D ₈ D ₉
	Drawing Data	D ₁ D ₂ D ₃ D ₄ D ₅ D ₆ D ₇ D ₆ D ₉ C/D Affix IBM modulus 10.
15 digits or more		Not to be drawn

(4) IBM modulus 10 + Auto affix of IBM modulus 10

No. of Input Digits		
Max. 13 digits	Input Data	D ₁ D ₂ D ₃ D ₄ D ₅ D ₆ D ₇ D ₈ D ₉
	Drawing Data	D ₁ D ₂ D ₃ D ₄ D ₅ D ₆ D ₇ D ₆ D ₉ C/D ₁ C/D ₂ Affix IBM modulus 10. Affix IBM modulus 10.
14 digits or more		Not to be drawn

(5) IBM modulus 11 + Auto affix of IBM modulus 10

No. of Input Digits		
Max. 13 digits	Input Data	D ₁ D ₂ D ₃ D ₄ D ₅ D ₆ D ₇ D ₈ D ₉
	Drawing Data	D ₁ D ₂ D ₃ D ₄ D ₅ D ₆ D ₇ D ₆ D ₉ C/D ₁ C/D ₂ Affix IBM modulus 10. Affix IBM modulus 11.
14 digits or more		Not to be drawn

Type of Bar Code: Interleaved 2 of 5

(1) No affix

No. of Input Digits		
Max. 126 digits	Input Data	D ₁ D ₂ D ₃ D ₄ D ₅ D ₆ D ₇ D ₈ D ₉ ↙ Not recognized as a check digit.
	Drawing Data	0 D ₁ D ₂ D ₃ D ₄ D ₅ D ₆ D ₇ D ₈ D ₉
127 digits or more		Not to be drawn

(2) Modulus 10 check

No. of Input Digits		
Min. 2 digits Max. 126 digits (including C/D)	Input Data	D ₁ D ₂ D ₃ D ₄ D ₅ D ₆ D ₇ D ₈ D ₉ ↙ To be checked as modulus 10 C/D
	Drawing Data	0 D ₁ D ₂ D ₃ D ₄ D ₅ D ₆ D ₇ D ₈ D ₉
1 digit 127 digits or more		Not to be drawn

(3) Auto affix of modulus 10

No. of Input Digits		
Max. 125 digits	Input Data	D ₁ D ₂ D ₃ D ₄ D ₅ D ₆ D ₇ D ₈ D ₉
	Drawing Data	D ₁ D ₂ D ₃ D ₄ D ₅ D ₆ D ₇ D ₆ D ₉ C/D ↙ Affix a modulus 10 C/D.
126 digits or more		Not to be drawn

(4) Auto affix of DBP modulus 10

No. of Input Digits		
Max. 125 digits	Input Data	D ₁ D ₂ D ₃ D ₄ D ₅ D ₆ D ₇ D ₈ D ₉
	Drawing Data	D ₁ D ₂ D ₃ D ₄ D ₅ D ₆ D ₇ D ₆ D ₉ C/D ↙ Affix a DBP modulus 10.
126 digits or more		Not to be drawn

Type of Bar Code: Industrial 2 of 5

(1) No affix

No. of Input Digits											
Max. 126 digits	Input Data	<table border="1"> <tr> <td>D₁</td><td>D₂</td><td>D₃</td><td>D₄</td><td>D₅</td><td>D₆</td><td>D₇</td><td>D₈</td><td>D₉</td> </tr> </table> <p style="text-align: right;">└ Not recognized as a check digit.</p>	D ₁	D ₂	D ₃	D ₄	D ₅	D ₆	D ₇	D ₈	D ₉
	D ₁	D ₂	D ₃	D ₄	D ₅	D ₆	D ₇	D ₈	D ₉		
Drawing Data	<table border="1"> <tr> <td>D₁</td><td>D₂</td><td>D₃</td><td>D₄</td><td>D₅</td><td>D₆</td><td>D₇</td><td>D₈</td><td>D₉</td> </tr> </table>	D ₁	D ₂	D ₃	D ₄	D ₅	D ₆	D ₇	D ₈	D ₉	
D ₁	D ₂	D ₃	D ₄	D ₅	D ₆	D ₇	D ₈	D ₉			
127 digits or more		Not to be drawn									

(2) Modulus check character check

No. of Input Digits											
Min. 2 digits Max. 126 digits (including C/D)	Input Data	<table border="1"> <tr> <td>D₁</td><td>D₂</td><td>D₃</td><td>D₄</td><td>D₅</td><td>D₆</td><td>D₇</td><td>D₈</td><td>D₉</td> </tr> </table> <p style="text-align: right;">└ To be checked as a modulus check character</p>	D ₁	D ₂	D ₃	D ₄	D ₅	D ₆	D ₇	D ₈	D ₉
	D ₁	D ₂	D ₃	D ₄	D ₅	D ₆	D ₇	D ₈	D ₉		
Drawing Data	<table border="1"> <tr> <td>D₁</td><td>D₂</td><td>D₃</td><td>D₄</td><td>D₅</td><td>D₆</td><td>D₇</td><td>D₈</td><td>D₉</td> </tr> </table>	D ₁	D ₂	D ₃	D ₄	D ₅	D ₆	D ₇	D ₈	D ₉	
D ₁	D ₂	D ₃	D ₄	D ₅	D ₆	D ₇	D ₈	D ₉			
1 digit 127 digits or more		Not to be drawn									

(3) Auto affix of modulus check character

No. of Input Digits											
Max. 125 digits	Input Data	<table border="1"> <tr> <td>D₁</td><td>D₂</td><td>D₃</td><td>D₄</td><td>D₅</td><td>D₆</td><td>D₇</td><td>D₈</td><td>D₉</td> </tr> </table>	D ₁	D ₂	D ₃	D ₄	D ₅	D ₆	D ₇	D ₈	D ₉
	D ₁	D ₂	D ₃	D ₄	D ₅	D ₆	D ₇	D ₈	D ₉		
Drawing Data	<table border="1"> <tr> <td>D₁</td><td>D₂</td><td>D₃</td><td>D₄</td><td>D₅</td><td>D₆</td><td>D₇</td><td>D₈</td><td>D₉</td><td>C/D</td> </tr> </table> <p style="text-align: right;">└ Affix a modulus check character.</p>	D ₁	D ₂	D ₃	D ₄	D ₅	D ₆	D ₇	D ₈	D ₉	C/D
D ₁	D ₂	D ₃	D ₄	D ₅	D ₆	D ₇	D ₈	D ₉	C/D		
126 digits or more		Not to be drawn									

Type of Bar Code: CODE39 (Standard)

(1) No affix

No. of Input Digits													
Max. 123 digits	Input Data	<table border="1"> <tr> <td>St</td><td>D₁</td><td>D₂</td><td>D₃</td><td>D₄</td><td>D₅</td><td>D₆</td><td>D₇</td><td>D₈</td><td>D₉</td><td>Sp</td> </tr> </table> <p>Start code (under St) Stop code (under Sp) Not recognized as a check digit.</p>	St	D ₁	D ₂	D ₃	D ₄	D ₅	D ₆	D ₇	D ₈	D ₉	Sp
	St	D ₁	D ₂	D ₃	D ₄	D ₅	D ₆	D ₇	D ₈	D ₉	Sp		
Drawing Data	<table border="1"> <tr> <td>St</td><td>D₁</td><td>D₂</td><td>D₃</td><td>D₄</td><td>D₅</td><td>D₆</td><td>D₇</td><td>D₈</td><td>D₉</td><td>Sp</td> </tr> </table> <p>————— —————</p>	St	D ₁	D ₂	D ₃	D ₄	D ₅	D ₆	D ₇	D ₈	D ₉	Sp	
St	D ₁	D ₂	D ₃	D ₄	D ₅	D ₆	D ₇	D ₈	D ₉	Sp			
124 digits or more		Not to be drawn											

(2) Modulus 43 check

No. of Input Digits													
Min. 2 digits Max. 123 digits (including C/D)	Input Data	<table border="1"> <tr> <td>St</td><td>D₁</td><td>D₂</td><td>D₃</td><td>D₄</td><td>D₅</td><td>D₆</td><td>D₇</td><td>D₈</td><td>D₉</td><td>Sp</td> </tr> </table> <p>Start code (under St) Stop code (under Sp) To be checked as modulus 43 C/D</p>	St	D ₁	D ₂	D ₃	D ₄	D ₅	D ₆	D ₇	D ₈	D ₉	Sp
	St	D ₁	D ₂	D ₃	D ₄	D ₅	D ₆	D ₇	D ₈	D ₉	Sp		
Drawing Data	<table border="1"> <tr> <td>St</td><td>D₁</td><td>D₂</td><td>D₃</td><td>D₄</td><td>D₅</td><td>D₆</td><td>D₇</td><td>D₈</td><td>D₉</td><td>Sp</td> </tr> </table> <p>————— —————</p>	St	D ₁	D ₂	D ₃	D ₄	D ₅	D ₆	D ₇	D ₈	D ₉	Sp	
St	D ₁	D ₂	D ₃	D ₄	D ₅	D ₆	D ₇	D ₈	D ₉	Sp			
1 digit 124 digits or more		Not to be drawn											

(3) Auto affix of modulus 43

No. of Input Digits													
Max. 122 digits	Input Data	<table border="1"> <tr> <td>St</td><td>D₁</td><td>D₂</td><td>D₃</td><td>D₄</td><td>D₅</td><td>D₆</td><td>D₇</td><td>D₈</td><td>D₉</td><td>Sp</td> </tr> </table> <p>Start code (under St) Stop code (under Sp)</p>	St	D ₁	D ₂	D ₃	D ₄	D ₅	D ₆	D ₇	D ₈	D ₉	Sp
	St	D ₁	D ₂	D ₃	D ₄	D ₅	D ₆	D ₇	D ₈	D ₉	Sp		
Drawing Data	<table border="1"> <tr> <td>St</td><td>D₁</td><td>D₂</td><td>D₃</td><td>D₄</td><td>D₅</td><td>D₆</td><td>D₇</td><td>D₈</td><td>D₉</td><td>C/D</td><td>Sp</td> </tr> </table> <p>————— ————— Affix a modulus 43 C/D.</p>	St	D ₁	D ₂	D ₃	D ₄	D ₅	D ₆	D ₇	D ₈	D ₉	C/D	Sp
St	D ₁	D ₂	D ₃	D ₄	D ₅	D ₆	D ₇	D ₈	D ₉	C/D	Sp		
123 digits or more		Not to be drawn											

Type of Bar Code: CODE39 (Full ASCII)

(1) No affix

No. of Input Digits																																			
Max. 60 digits	Input Data	<table border="1"> <tr> <td>St</td><td>D₁</td><td>D₂</td><td>D₃</td><td>D₄</td><td>D₅</td><td>D₆</td><td>D₇</td><td>D₈</td><td>D₉</td><td>Sp</td> </tr> <tr> <td colspan="10" style="text-align: center;">Start code</td> <td style="text-align: center;">Stop code</td> </tr> <tr> <td colspan="11" style="text-align: center;">Not recognized as a check digit.</td> </tr> </table>	St	D ₁	D ₂	D ₃	D ₄	D ₅	D ₆	D ₇	D ₈	D ₉	Sp	Start code										Stop code	Not recognized as a check digit.										
	St	D ₁	D ₂	D ₃	D ₄	D ₅	D ₆	D ₇	D ₈	D ₉	Sp																								
Start code										Stop code																									
Not recognized as a check digit.																																			
Drawing Data	<table border="1"> <tr> <td>St</td><td>D₁</td><td>D₂</td><td>D₃</td><td>D₄</td><td>D₅</td><td>D₆</td><td>D₇</td><td>D₈</td><td>D₉</td><td>Sp</td> </tr> <tr> <td colspan="11" style="text-align: center;">—————</td> </tr> </table>	St	D ₁	D ₂	D ₃	D ₄	D ₅	D ₆	D ₇	D ₈	D ₉	Sp	—————																						
St	D ₁	D ₂	D ₃	D ₄	D ₅	D ₆	D ₇	D ₈	D ₉	Sp																									
—————																																			
61 digits or more		Not to be drawn																																	

(2) Modulus 43 check

No. of Input Digits																																			
Min. 2 digits Max. 60 digits (including C/D)	Input Data	<table border="1"> <tr> <td>St</td><td>D₁</td><td>D₂</td><td>D₃</td><td>D₄</td><td>D₅</td><td>D₆</td><td>D₇</td><td>D₈</td><td>D₉</td><td>Sp</td> </tr> <tr> <td colspan="10" style="text-align: center;">Start code</td> <td style="text-align: center;">Stop code</td> </tr> <tr> <td colspan="11" style="text-align: center;">To be checked as modulus 43 C/D</td> </tr> </table>	St	D ₁	D ₂	D ₃	D ₄	D ₅	D ₆	D ₇	D ₈	D ₉	Sp	Start code										Stop code	To be checked as modulus 43 C/D										
	St	D ₁	D ₂	D ₃	D ₄	D ₅	D ₆	D ₇	D ₈	D ₉	Sp																								
Start code										Stop code																									
To be checked as modulus 43 C/D																																			
Drawing Data	<table border="1"> <tr> <td>St</td><td>D₁</td><td>D₂</td><td>D₃</td><td>D₄</td><td>D₅</td><td>D₆</td><td>D₇</td><td>D₈</td><td>D₉</td><td>Sp</td> </tr> <tr> <td colspan="11" style="text-align: center;">—————</td> </tr> </table>	St	D ₁	D ₂	D ₃	D ₄	D ₅	D ₆	D ₇	D ₈	D ₉	Sp	—————																						
St	D ₁	D ₂	D ₃	D ₄	D ₅	D ₆	D ₇	D ₈	D ₉	Sp																									
—————																																			
1 digit 61 digits or more		Not to be drawn																																	

(3) Auto affix of modulus 43

No. of Input Digits																																			
Max. 60 digits	Input Data	<table border="1"> <tr> <td>St</td><td>D₁</td><td>D₂</td><td>D₃</td><td>D₄</td><td>D₅</td><td>D₆</td><td>D₇</td><td>D₈</td><td>D₉</td><td>Sp</td> </tr> <tr> <td colspan="10" style="text-align: center;">Start code</td> <td style="text-align: center;">Stop code</td> </tr> </table>	St	D ₁	D ₂	D ₃	D ₄	D ₅	D ₆	D ₇	D ₈	D ₉	Sp	Start code										Stop code											
	St	D ₁	D ₂	D ₃	D ₄	D ₅	D ₆	D ₇	D ₈	D ₉	Sp																								
Start code										Stop code																									
Drawing Data	<table border="1"> <tr> <td>St</td><td>D₁</td><td>D₂</td><td>D₃</td><td>D₄</td><td>D₅</td><td>D₆</td><td>D₇</td><td>D₈</td><td>D₉</td><td>C/D</td><td>Sp</td> </tr> <tr> <td colspan="11" style="text-align: center;">—————</td> </tr> <tr> <td colspan="11" style="text-align: center;">Affix a modulus 43 C/D.</td> </tr> </table>	St	D ₁	D ₂	D ₃	D ₄	D ₅	D ₆	D ₇	D ₈	D ₉	C/D	Sp	—————											Affix a modulus 43 C/D.										
St	D ₁	D ₂	D ₃	D ₄	D ₅	D ₆	D ₇	D ₈	D ₉	C/D	Sp																								
—————																																			
Affix a modulus 43 C/D.																																			
61 digits or more		Not to be drawn																																	

NOTE: Numerals under bars are not characters corresponding to the bars but the characters of the codes received are drawn.

Type of Bar Code: NW7

- (1) No affix
- C/D check
- Auto affix

No. of Input Digits																								
Max. 125 digits	Input Data	<table border="1"> <tr> <td>St</td><td>D₁</td><td>D₂</td><td>D₃</td><td>D₄</td><td>D₅</td><td>D₆</td><td>D₇</td><td>D₈</td><td>D₉</td><td>Sp</td> </tr> <tr> <td colspan="10" style="text-align: center;">Start code</td> <td style="text-align: center;">Stop code</td> </tr> </table>	St	D ₁	D ₂	D ₃	D ₄	D ₅	D ₆	D ₇	D ₈	D ₉	Sp	Start code										Stop code
	St	D ₁	D ₂	D ₃	D ₄	D ₅	D ₆	D ₇	D ₈	D ₉	Sp													
Start code										Stop code														
Drawing Data	<table border="1"> <tr> <td>St</td><td>D₁</td><td>D₂</td><td>D₃</td><td>D₄</td><td>D₅</td><td>D₆</td><td>D₇</td><td>D₈</td><td>D₉</td><td>Sp</td> </tr> <tr> <td colspan="11" style="text-align: center;">—————</td> </tr> </table>	St	D ₁	D ₂	D ₃	D ₄	D ₅	D ₆	D ₇	D ₈	D ₉	Sp	—————											
St	D ₁	D ₂	D ₃	D ₄	D ₅	D ₆	D ₇	D ₈	D ₉	Sp														
—————																								
126 digits or more		Not to be drawn																						

Type of Bar Code: No auto selection of CODE128 (Character ">" to be also counted as a digit)

- (1) No affix
- PSEUDO103 check
- Auto affix of PSEUDO103

No. of Input Digits		
Min. 3 digits Max. 125 digits (including start code)	Input Data	St D ₁ D ₂ D ₃ D ₄ D ₅ D ₆ D ₇ D ₈ D ₉ D ₁₀ D ₁₁
	Drawing Data	St D ₁ D ₂ D ₃ D ₄ D ₅ D ₆ D ₇ D ₈ D ₉ D ₁₀ D ₁₁ C/D Sp <div style="text-align: right; margin-top: -10px;">└ Affix PSEUDO103 C/D.</div>
2 digits or less 126 digits or more		Not to be drawn

NOTE: The following characters are not drawn as numerals under bars.
 NUL (00H) to US (1FH), FNC1, FNC2, FNC3, SHIFT, CODE A, CODE B, CODE C

Type of Bar Code: Auto selection of CODE 128

- (1) No affix
- C/D check
- Auto affix of C/D

No. of Input Digits		
Max. 60 digits	Input Data	D ₁ D ₂ D ₃ D ₄ D ₅ D ₆ D ₇ D ₈ D ₉ D ₁₀ D ₁₁
	Drawing Data	St D ₁ D ₂ D ₃ D ₄ AD D ₅ D ₆ D ₇ AD D ₈ D ₉ D ₁₀ D ₁₁ C/D Sp <div style="display: flex; justify-content: space-between; margin-top: -10px;"> <div style="width: 30%;">└ Start code</div> <div style="width: 40%;">└ Selection code</div> <div style="width: 20%;">└ Stop code</div> </div> <div style="text-align: right; margin-top: 10px;">└ Affix PSEUDO103 C/D.</div>
61 digits or more		Not to be drawn

NOTE: The following characters are not drawn as numerals under bars.
 NUL (00H) to US (1FH), FNC1, FNC2, FNC3, SHIFT, CODE A, CODE B, CODE C

Type of Bar Code: CODE93

- (1) No affix
- C/D check
- Auto affix of C/D

No. of Input Digits														
Max. 60 digits	Input Data	D ₁ D ₂ D ₃ D ₄ D ₅ D ₆ D ₇ D ₈ D ₉												
	Drawing Data	<table border="1" style="width: 100%; border-collapse: collapse;"> <tr> <td style="width: 20px;">St</td> <td style="width: 20px;">D₁</td> <td style="width: 20px;">D₂</td> <td style="width: 20px;">D₃</td> <td style="width: 20px;">D₄</td> <td style="width: 20px;">D₅</td> <td style="width: 20px;">D₆</td> <td style="width: 20px;">D₇</td> <td style="width: 20px;">D₈</td> <td style="width: 20px;">D₉</td> <td style="width: 20px;">C/D₁</td> <td style="width: 20px;">C/D₂</td> <td style="width: 20px;">Sp</td> </tr> </table> <p style="margin-left: 40px;"> Start code Affix a modulus 47 "K" C/D. Affix a modulus 47 "C" C/D. Stop code </p>	St	D ₁	D ₂	D ₃	D ₄	D ₅	D ₆	D ₇	D ₈	D ₉	C/D ₁	C/D ₂
St	D ₁	D ₂	D ₃	D ₄	D ₅	D ₆	D ₇	D ₈	D ₉	C/D ₁	C/D ₂	Sp		
61 digits or more		Not to be drawn												

NOTE: Numerals under bars are not characters corresponding to the bars but the characters of the codes received are drawn.

Type of Bar Code: UCC/EAN128

- (1) No affix
- C/D check
- Auto affix of C/D

No. of Input Digits																			
19 digits	Input Data	D ₁ D ₂ D ₃ D ₄ D ₅ D ₆ ... D ₁₄ D ₁₅ D ₁₆ D ₁₇ D ₁₈ D ₁₉																	
	Drawing Data	<table border="1" style="width: 100%; border-collapse: collapse;"> <tr> <td style="width: 20px;">St</td> <td style="width: 20px;">FNC1</td> <td style="width: 20px;">D₁</td> <td style="width: 20px;">D₂</td> <td style="width: 20px;">D₃</td> <td style="width: 20px;">D₄</td> <td style="width: 20px;">D₅</td> <td style="width: 20px;">D₆</td> <td style="width: 20px;">...</td> <td style="width: 20px;">D₁₄</td> <td style="width: 20px;">D₁₅</td> <td style="width: 20px;">D₁₆</td> <td style="width: 20px;">D₁₇</td> <td style="width: 20px;">D₁₈</td> <td style="width: 20px;">D₁₉</td> <td style="width: 20px;">C/D₁</td> <td style="width: 20px;">C/D₂</td> <td style="width: 20px;">Sp</td> </tr> </table> <p style="margin-left: 40px;"> Start code Affix a modulus 10 C/D. Affix a modulus 103 C/D. Stop code </p>	St	FNC1	D ₁	D ₂	D ₃	D ₄	D ₅	D ₆	...	D ₁₄	D ₁₅	D ₁₆	D ₁₇	D ₁₈	D ₁₉	C/D ₁	C/D ₂
St	FNC1	D ₁	D ₂	D ₃	D ₄	D ₅	D ₆	...	D ₁₄	D ₁₅	D ₁₆	D ₁₇	D ₁₈	D ₁₉	C/D ₁	C/D ₂	Sp		
Other than 19 digits		Not to be drawn																	

Type of Bar Code: POSTNET

(1) Auto affix of dedicated C/D

No. of Input Digits																		
5 digits	Input Data	D ₁ D ₂ D ₃ D ₄ D ₅																
	Drawing Data	<table border="1" style="display: inline-table; border-collapse: collapse;"> <tr> <td>St</td><td>D₁</td><td>D₂</td><td>D₃</td><td>D₄</td><td>D₅</td><td>C/D</td><td>Sp</td> </tr> </table> Start code (under St) Stop code (under C/D) Dedicated check digit (under C/D)	St	D ₁	D ₂	D ₃	D ₄	D ₅	C/D	Sp								
St	D ₁	D ₂	D ₃	D ₄	D ₅	C/D	Sp											
9 digits	Input Data	D ₁ D ₂ D ₃ D ₄ D ₅ D ₆ D ₇ D ₈ D ₉																
	Drawing Data	<table border="1" style="display: inline-table; border-collapse: collapse;"> <tr> <td>St</td><td>D₁</td><td>D₂</td><td>D₃</td><td>D₄</td><td>D₅</td><td>D₆</td><td>D₇</td><td>D₈</td><td>D₉</td><td>C/D</td><td>Sp</td> </tr> </table> Start code (under St) Stop code (under C/D) Dedicated check digit (under C/D)	St	D ₁	D ₂	D ₃	D ₄	D ₅	D ₆	D ₇	D ₈	D ₉	C/D	Sp				
St	D ₁	D ₂	D ₃	D ₄	D ₅	D ₆	D ₇	D ₈	D ₉	C/D	Sp							
11 digits	Input Data	D ₁ D ₂ D ₃ D ₄ D ₅ D ₆ D ₇ D ₈ D ₉ D ₁₀ D ₁₁																
	Drawing Data	<table border="1" style="display: inline-table; border-collapse: collapse;"> <tr> <td>St</td><td>D₁</td><td>D₂</td><td>D₃</td><td>D₄</td><td>D₅</td><td>C/D</td><td>Sp</td><td>Fr</td><td>D₆</td><td>D₇</td><td>D₈</td><td>D₉</td><td>D₁₀</td><td>D₁₁</td><td>C/D</td><td>Fr</td> </tr> </table> Start code (under St) Frame (under Fr) Stop code (under C/D) Dedicated check digit (under C/D) Frame (under Fr)	St	D ₁	D ₂	D ₃	D ₄	D ₅	C/D	Sp	Fr	D ₆	D ₇	D ₈	D ₉	D ₁₀	D ₁₁	C/D
St	D ₁	D ₂	D ₃	D ₄	D ₅	C/D	Sp	Fr	D ₆	D ₇	D ₈	D ₉	D ₁₀	D ₁₁	C/D	Fr		
Other than 5, 9, and 11 digits		Not to be drawn																

Type of Bar Code: RM4SCC

(1) Auto affix of dedicated C/D

No. of Input Digits																
12 digits	Input Data	(St) D ₁ D ₂ D ₃ D ₄ D ₅ D ₆ D ₇ D ₈ D ₉ D ₁₀ D ₁₁ D ₁₂ (Sp)														
	Drawing Data	<table border="1" style="display: inline-table; border-collapse: collapse;"> <tr> <td>St</td><td>D₁</td><td>D₂</td><td>D₃</td><td>D₄</td><td>D₅</td><td>D₆</td><td>D₇</td><td>D₈</td><td>D₉</td><td>D₁₀</td><td>D₁₁</td><td>D₁₂</td><td>C/D</td><td>Sp</td> </tr> </table> Start code (under St) Stop code (under Sp) Dedicated check digit (under C/D)	St	D ₁	D ₂	D ₃	D ₄	D ₅	D ₆	D ₇	D ₈	D ₉	D ₁₀	D ₁₁	D ₁₂	C/D
St	D ₁	D ₂	D ₃	D ₄	D ₅	D ₆	D ₇	D ₈	D ₉	D ₁₀	D ₁₁	D ₁₂	C/D	Sp		
13 digits or more		Not to be drawn														

Type of Bar Code: KIX CODE

(1) No affix

No. of Input Digits		
18 digits	Input Data	D ₁ D ₂ D ₃ D ₄ D ₅ D ₆ D ₇ D ₈ D ₉ D ₁₀ D ₁₁ D ₁₂ D ₁₃ D ₁₄ D ₁₅ D ₁₆ D ₁₇ D ₁₈
	Drawing Data	D ₁ D ₂ D ₃ D ₄ D ₅ D ₆ D ₇ D ₈ D ₉ D ₁₀ D ₁₁ D ₁₂ D ₁₃ D ₁₄ D ₁₅ D ₁₆ D ₁₇ D ₁₈
19 digits or more		Not to be drawn

Type of Bar Code: Customer bar code

(1) Auto affix of dedicated C/D

No. of Input Digits																																																																	
20 digits	Input Data	D ₁ D ₂ D ₃ D ₄ D ₅ D ₆ D ₇ D ₈ D ₉ D ₁₀ D ₁₁ D ₁₂ D ₁₃ D ₁₄ D ₁₅ D ₁₆ D ₁₇ D ₁₈ D ₁₉ D ₂₀																																																															
	Drawing Data	<table border="1" style="width: 100%; border-collapse: collapse;"> <tr> <td style="width: 2%;">St</td> <td style="width: 2%;">D₁</td> <td style="width: 2%;">D₂</td> <td style="width: 2%;">D₃</td> <td style="width: 2%;">D₄</td> <td style="width: 2%;">D₅</td> <td style="width: 2%;">D₆</td> <td style="width: 2%;">D₇</td> <td style="width: 2%;">D₈</td> <td style="width: 2%;">D₉</td> <td style="width: 2%;">D₁₀</td> <td style="width: 2%;">D₁₁</td> <td style="width: 2%;">D₁₂</td> <td style="width: 2%;">D₁₃</td> <td style="width: 2%;">D₁₄</td> <td style="width: 2%;">D₁₅</td> <td style="width: 2%;">D₁₆</td> <td style="width: 2%;">D₁₇</td> <td style="width: 2%;">D₁₈</td> <td style="width: 2%;">D₁₉</td> <td style="width: 2%;">D₂₀</td> <td style="width: 2%;">C/D</td> <td style="width: 2%;">Sp</td> </tr> <tr> <td colspan="10" style="text-align: left;">└─ Start code</td> <td colspan="10" style="text-align: right;">Dedicated check digit ─┘</td> </tr> <tr> <td colspan="21" style="text-align: right;">Stop code ─┘</td> </tr> </table>	St	D ₁	D ₂	D ₃	D ₄	D ₅	D ₆	D ₇	D ₈	D ₉	D ₁₀	D ₁₁	D ₁₂	D ₁₃	D ₁₄	D ₁₅	D ₁₆	D ₁₇	D ₁₈	D ₁₉	D ₂₀	C/D	Sp	└─ Start code										Dedicated check digit ─┘										Stop code ─┘																			
St	D ₁	D ₂	D ₃	D ₄	D ₅	D ₆	D ₇	D ₈	D ₉	D ₁₀	D ₁₁	D ₁₂	D ₁₃	D ₁₄	D ₁₅	D ₁₆	D ₁₇	D ₁₈	D ₁₉	D ₂₀	C/D	Sp																																											
└─ Start code										Dedicated check digit ─┘																																																							
Stop code ─┘																																																																	
21 digits or more		Data of up to 20 digits is drawn. Data of 21 digits or more is discarded.																																																															

Type of Bar Code: Highest priority customer bar code

(1) Auto affix of dedicated C/D

No. of Input Digits																																																																																						
19 digits	Input Data	D ₁ D ₂ D ₃ D ₄ D ₅ D ₆ D ₇ D ₈ D ₉ D ₁₀ D ₁₁ D ₁₂ D ₁₃ D ₁₄ D ₁₅ D ₁₆ D ₁₇ D ₁₈ D ₁₉																																																																																				
	Drawing Data	<table border="1" style="width: 100%; border-collapse: collapse;"> <tr> <td style="width: 2%;">St</td> <td style="width: 2%;">D₁</td> <td style="width: 2%;">D₂</td> <td style="width: 2%;">D₃</td> <td style="width: 2%;">D₄</td> <td style="width: 2%;">D₅</td> <td style="width: 2%;">D₆</td> <td style="width: 2%;">D₇</td> <td style="width: 2%;">D₈</td> <td style="width: 2%;">D₉</td> <td style="width: 2%;">D₁₀</td> <td style="width: 2%;">D₁₁</td> <td style="width: 2%;">D₁₂</td> <td style="width: 2%;">D₁₃</td> <td style="width: 2%;">D₁₄</td> <td style="width: 2%;">D₁₅</td> <td style="width: 2%;">D₁₆</td> <td style="width: 2%;">D₁₇</td> <td style="width: 2%;">D₁₈</td> <td style="width: 2%;">D₁₉</td> <td style="width: 2%;">CC7</td> <td style="width: 2%;">C/D</td> <td style="width: 2%;">Sp</td> </tr> <tr> <td colspan="10" style="text-align: left;">└─ Start code</td> <td colspan="10" style="text-align: right;">CC7 ─┘</td> </tr> <tr> <td colspan="21" style="text-align: right;">Dedicated check digit ─┘</td> </tr> <tr> <td colspan="21" style="text-align: right;">Stop code ─┘</td> </tr> </table>	St	D ₁	D ₂	D ₃	D ₄	D ₅	D ₆	D ₇	D ₈	D ₉	D ₁₀	D ₁₁	D ₁₂	D ₁₃	D ₁₄	D ₁₅	D ₁₆	D ₁₇	D ₁₈	D ₁₉	CC7	C/D	Sp	└─ Start code										CC7 ─┘										Dedicated check digit ─┘																					Stop code ─┘																			
St	D ₁	D ₂	D ₃	D ₄	D ₅	D ₆	D ₇	D ₈	D ₉	D ₁₀	D ₁₁	D ₁₂	D ₁₃	D ₁₄	D ₁₅	D ₁₆	D ₁₇	D ₁₈	D ₁₉	CC7	C/D	Sp																																																																
└─ Start code										CC7 ─┘																																																																												
Dedicated check digit ─┘																																																																																						
Stop code ─┘																																																																																						
20 digits or more		Data of up to 19 digits is drawn. Data of 20 digits or more is discarded.																																																																																				

14. AUTOMATIC ADDING OF START/STOP CODE

Type of Bar Code	Designation of Start/Stop Code	Input Data	Drawing Data	
CODE 39	Omit (No designation)	12345ABC	Standard	*12345ABC*
			Full ASCII	*12345ABC*
		*12345ABC	Standard	*12345ABC*
			Full ASCII	*12345ABC*
		12345ABC*	Standard	*12345ABC*
			Full ASCII	*12345ABC*
		12345ABC	Standard	*12345ABC*
			Full ASCII	*12345ABC*
		12345*ABC	Standard	*12345*ABC*
			Full ASCII	*12345/JABC*
		**12345ABC	Standard	**12345ABC*
			Full ASCII	*/J12345ABC*
		*12345ABC**	Standard	*12345ABC**
			Full ASCII	*12345ABC/J*
		*12345*ABC*	Standard	*12345*ABC*
			Full ASCII	*12345/JABC*
		12345ABC	Standard	*12345ABC
			Full ASCII	*12345ABC
		*12345ABC	Standard	**12345ABC
			Full ASCII	*/J12345ABC
		12345ABC*	Standard	*12345ABC*
			Full ASCII	*12345ABC*
		12345ABC	Standard	**12345ABC*
			Full ASCII	*/J12345ABC*
	12345*ABC	Standard	*12345*ABC	
		Full ASCII	*12345/JABC	
	12345ABC	Standard	*12345ABC	
		Full ASCII	*/J/J12345ABC	
	*12345ABC**	Standard	**12345ABC**	
		Full ASCII	*/J12345ABC/J*	
	*12345*ABC*	Standard	**12345*ABC*	
		Full ASCII	*/J12345/JABC*	
	12345ABC	Standard	12345ABC*	
		Full ASCII	12345ABC*	
	*12345ABC	Standard	*12345ABC*	
		Full ASCII	*12345ABC*	
	12345ABC*	Standard	12345ABC**	
		Full ASCII	12345ABC/J*	
	12345ABC	Standard	*12345ABC**	
		Full ASCII	*12345ABC/J*	
	12345*ABC	Standard	12345*ABC*	
		Full ASCII	12345/JABC*	
	**12345ABC	Standard	**12345ABC*	
		Full ASCII	*/J12345ABC*	
	*12345ABC**	Standard	*12345ABC***	
		Full ASCII	*12345ABC/J/J*	
	*12345*ABC*	Standard	*12345*ABC**	
		Full ASCII	*12345/JABC/J*	

Type of Bar Code	Designation of Start/Stop Code	Input Data	Drawing Data	
CODE 39	Start/stop code not added	12345ABC	Standard	12345ABC
			Full ASCII	12345ABC
		*12345ABC	Standard	*12345ABC
			Full ASCII	*12345ABC
		12345ABC*	Standard	12345ABC*
			Full ASCII	12345ABC*
		12345ABC	Standard	*12345ABC*
			Full ASCII	*12345ABC*
		12345*ABC	Standard	12345*ABC
			Full ASCII	12345/JABC
		**12345ABC	Standard	**12345ABC
			Full ASCII	*/J12345ABC
		*12345ABC**	Standard	*12345ABC**
			Full ASCII	*12345ABC/J*
		*12345*ABC*	Standard	*12345*ABC*
			Full ASCII	*12345/JABC*

Type of Bar Code	Designation of Start/Stop Code	Input Data	Drawing Data
NW7	Omit (No designation)	12345678	a12345678a
		a12345678	a12345678
		12345678c	12345678c
		b12345678d	b12345678d
		12345a678	a12345a678a
		ab12345678	ab12345678
		a12345678bc	a12345678bc
		d12345b678c	d12345b678c
	Add start code	12345678	a12345678
		a12345678	aa12345678
		12345678c	a12345678c
		b12345678d	ab12345678d
		12345a678	a12345a678
		ab12345678	aab12345678
		a12345678bc	aa12345678bc
		d12345b678c	ad12345b678c
	Add stop code	12345678	12345678a
		a12345678	a12345678a
		12345678c	12345678ca
		b12345678d	b12345678da
		12345a678	12345a678a
		ab12345678	ab12345678a
		a12345678bc	a12345678bca
		d12345b678c	d12345b678ca
	Start/stop code not added	12345678	12345678
		a12345678	a12345678
		12345678c	12345678c
		b12345678d	b12345678d
		12345a678	12345a678
		ab12345678	ab12345678
		a12345678bc	a12345678bc
		d12345b678c	d12345b678c